

A 3Y/3Y Pole-Changing Winding of High-Power Asynchronous Motors

Gábor Kovács

Abstract—Requirement for pole-changing motors emerged at the very early times of asynchronous motor design. Different solutions have been elaborated and some of them are generally used. An alternative is the so called 3 Y/3 Y pole-changing winding. This paper deals with high power application of this solution. A complete and comprehensive study is introduced, including features and design guidelines. The method presented in this paper is especially suitable for pole numbers being close to each other. The study also reveals that the method is more advantageous than the existing solutions for high power motors with 1:3 pole ratio. Using this motor, a new and complete drive supply system has been proposed as most appropriate arrangement of high power main naval propulsion drive. Further, the method makes possible to extend the pole ratio to 1:6, 1:9, 1:12, etc. At the end, the proposal is further extended to the here so far missing 1:4, 1:5, 1:7 etc. pole ratios. A complete proposal for the theoretically infinite range has been given in this way.

Keywords—Induction motor, pole changing 3Y/3Y, pole phase modulation, pole changing 1:3, 1:4, 1:5, 1:6.

I. INTRODUCTION

THE objective of motor designers for industrial use was, from the beginning, to provide two speeds in a single motor instead of one speed only.

There are two main methods for pole changing of motors which are most generally used. The first method creates two independent windings in the stator, which is basically two motors in one: both windings can be ideally designed for their respective speeds. The size of such motors is, however, much bigger than the size of a single speed motor: not two times but at least 1.6 times bigger. This is due to the fact that only one of the two windings is working at any given moment, whereas the other one remains idle, taking up valuable space in the active part of the motor. Example: a 3.6 MW 6-pole / 1 MW 8-pole double-speed motor is the same size as a 6 MW 6-pole single speed motor. This is called as necessary derating being now 60%. With this method, practically any pole combination can be implemented [4].

The second method is based on changing the connection of parts of a winding called as pole amplitude modulation (PAM motor): a part of the winding is connected in a to-and-back direction for achieving the basic and then the modulated pole number (the so-called Dahlander-connection for 1:2 speeds is a special case of this arrangement). Although the entire winding is working on both speeds at any given moment, two inherent disadvantages cannot be avoided: a number of

additional terminals are required, therefore the drive must be fitted with a specially designed switching apparatus, and the magnetic field/wave in the airgap is always considerably distorted on the modulated speed. With this method, the possible pole combinations are limited.

II. 3//Y / 3//Y METHOD

Another less frequently used method is the so-called 3//Y/3//Y method.

The main advantage of this solution is that the entire winding is working at any given moment. At the same time, however, certain characteristics may be unfavourable. Theoretical and scientific considerations are proposed in order to bypass those characteristics (like [3] and many more). However, the proposed improvement methods are complicated from a mechanical point of view, such as incurring different turn numbers per slot, being applicable for laboratory-size motors but cannot be applied for high-power motors. Consequently, there are a considerable number of proposals for low-power fields, but it seems that there is a lack of a complete and comprehensive study for high-power applications, including design guidelines.

The main disadvantage of this method is that it may have some undesirable consequences for the motor, such as certain asymmetry and additional even harmonics values. However, if the motor is designed prudently, based on the accurate calculations of these characteristics and careful evaluation, it will operate without any problems.

In this paper, we focus on high-power applications and present both the advantages and disadvantages of the 3//Y/3//Y method. For this reason, we do not discuss solutions which are inadequate for large high-voltage high-power motors.

In the second part of the article, a solution is presented for 1:3, 1:6, etc. pole ratio. Several papers have been published in the last decades on this topic, starting with that of [7] for pole changing in ratio 1:3, up to today such as in [8] where the usefulness and necessity of 9-phase supply on the lower pole number was recognized. Their target was always to find solution for a specific application only, therefore they lack general applicability.

The design method presented in this paper is therefore unique in the sense that:

- it is based on a very general approach,
- it allows further development of the idea, e.g. extending the application not only for 1:3 ratio but up to 1:6, 1:9, etc., as well as for 1:4, 1:5, 1:7 etc. which is a lack among the many proposals for pole changing windings;

Gábor Kovács is consultant engineer with Ganz Electric Works, Budapest, Hungary, called at the moment CG Electric Systems Hungary, 1095 Budapest, Hungary (phone: + 36 1 483 6840, + 36 20 823 2515, e-mail: gabor.kovacs@cglobal.com).

- it allows such motor to become the core element of a new drive system for high power main naval propulsion; and finally
- Due to the relatively simple winding solution, it facilitates the high-power application, indeed.

III. BASIC IDEA BEHIND THE 3//Y/3//Y METHOD

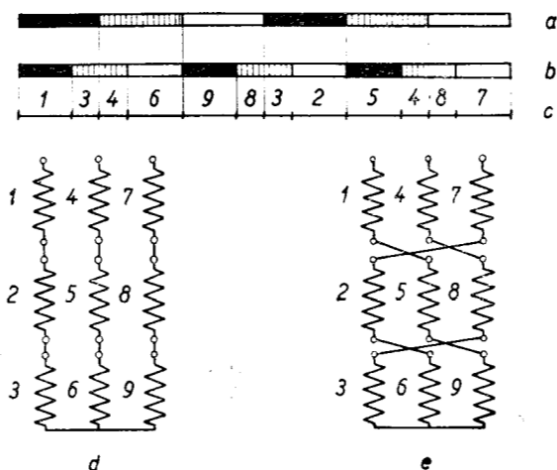

Fig. 1 Classical pole changing winding according to [1] (a) upper layer for 4-pole connection, (b) upper layer for 6-pole connection, (c) subdivision of the winding, (d) connection of winding for 4-pole, (e) connection of winding for 6-pole

Fig. 1 (see [1]) shows a pole-changing connection for 4/6 pole. Instead of the usual 60° phase belt, such connections are prepared with a 120° phase belt and two-layer winding. Figs. 1 (a) and (b) show the upper layer for 4-pole and 6-pole connections, respectively. Fig. 1 (c) shows the necessary subdivision into parts being smaller than q slot (slot number per phase per pole) on either pole number. The figure indicates the relationship between those subdivided parts of the winding and phases, indicating a 4-pole connection in one case (d) and a 6-pole connection in the other (e). It is clear that certain winding parts belong to a certain phase for 4-pole and a different phase for 6-pole. Such solutions are known as phase modulating methods.

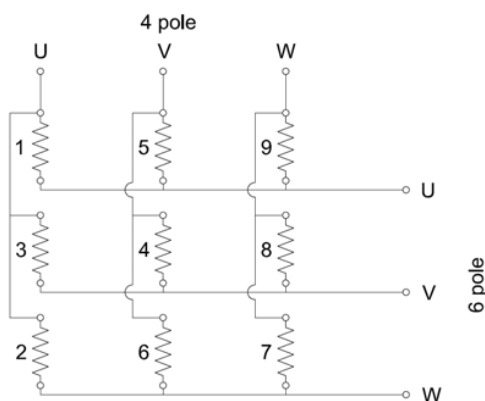

Fig. 2 Pole changing winding by 3//Y / 3//Y method

In subject case, winding group 1, 4, 7 remains in the same phase; however, all the rest is moved to another phase. Because the groups are connected into series, 15 terminals and an appropriate switch are required.

It is clear that groups 2, 5, 8 as well as 3,6,9 shall be identical among each other, otherwise they could not be interchanged with each other.

If we consider those three groups, it becomes clear that

- group 1, 4, 7, group 2, 5, 8 and as group 3,6,9 are also identical with each other meaning that they may be connected in parallel;
- as a consequence, there is no need for a large number of terminals just because of connecting them in parallel; three terminals are enough for each pole.

See connection pattern on Fig. 2.

A. Features

Before going more into details, it is better to discuss the above mentioned parallel connection again.

As seen, both partial 3-piece 3-phase systems are symmetrical on both numbers of poles, meaning that their parallel connection can be implemented indeed. At the moment, symmetry is nothing more than having equal number of groups (= equal number of turns) in each system connected in parallel. However, closer scrutiny reveals that the other condition of symmetry, which is 120° phase symmetry, is not fulfilled in all cases. If the pole number is not integer multiple of 6, phase symmetry is not possible no matter it is the higher or lower pole number. Here, asymmetry leads to phase unbalance, which means that the “distance” between voltages induced within the groups by the resulting (= one and only) rotating air-gap flux is not 120° (e.g. not 120° – 240° – 360°) anymore, but roughly around 110° – 240° – 370° or so, like here in the 4-pole arrangement. This will cause balancing – equalizing currents in phase U and W, more at low pole numbers (like here at 4/6 pole), less at high pole numbers (like 12/16 pole for example).

The explanation is as follows. Usually, each pole of each phase (q slots) is a separate unit, being connected always into series. In actual pole-changing winding, however, even such groups of q slots are first cut into pieces and then “put together” again but taken from different parts of the winding, not always with the appropriate electrical angle. Once again in reference to Fig. 1 (b), it is clear that in 6-pole connection, 1, 4, 7 are at a “distance” of 120° – 240° – 360° from each other when induced by a 6-pole rotating magnetic field. It is not the case, however, when induced by a 4-pole rotating magnetic field: this case (1, 4, 7) is definitely not at a “distance” of 120° – 240° – 360°. Due to the losses caused by the unavoidable balancing currents the motor rated power must be reduced, the motor must be “derated” by derating factor k_2 , further discussed in chapter F. Derating.

Now let us continue with the actual implementation by showing both layers of the winding. Unlike in Fig. 1, from now on, we take a 6-8-pole winding as example. In Fig. 3, we show a real and actual winding scheme, just to demonstrate how the method works. Fig. 3 (a) shows the result supplied at

the terminals marked for 6-pole, Fig. 3 (b) shows the result supplied at the terminals marked for 8-pole.

There are three terminals for both pole numbers: one group is used for power supply for 6-pole, whereas the other three terminals are used as the star points, therefore these remain

idle. The opposite is true for 8-pole: the other group of three terminals, used earlier as star points, is used now for power supply, whereas the former group remains idle as star points. Those terminals, serving actually for star-points, do not need to be short-circuited.

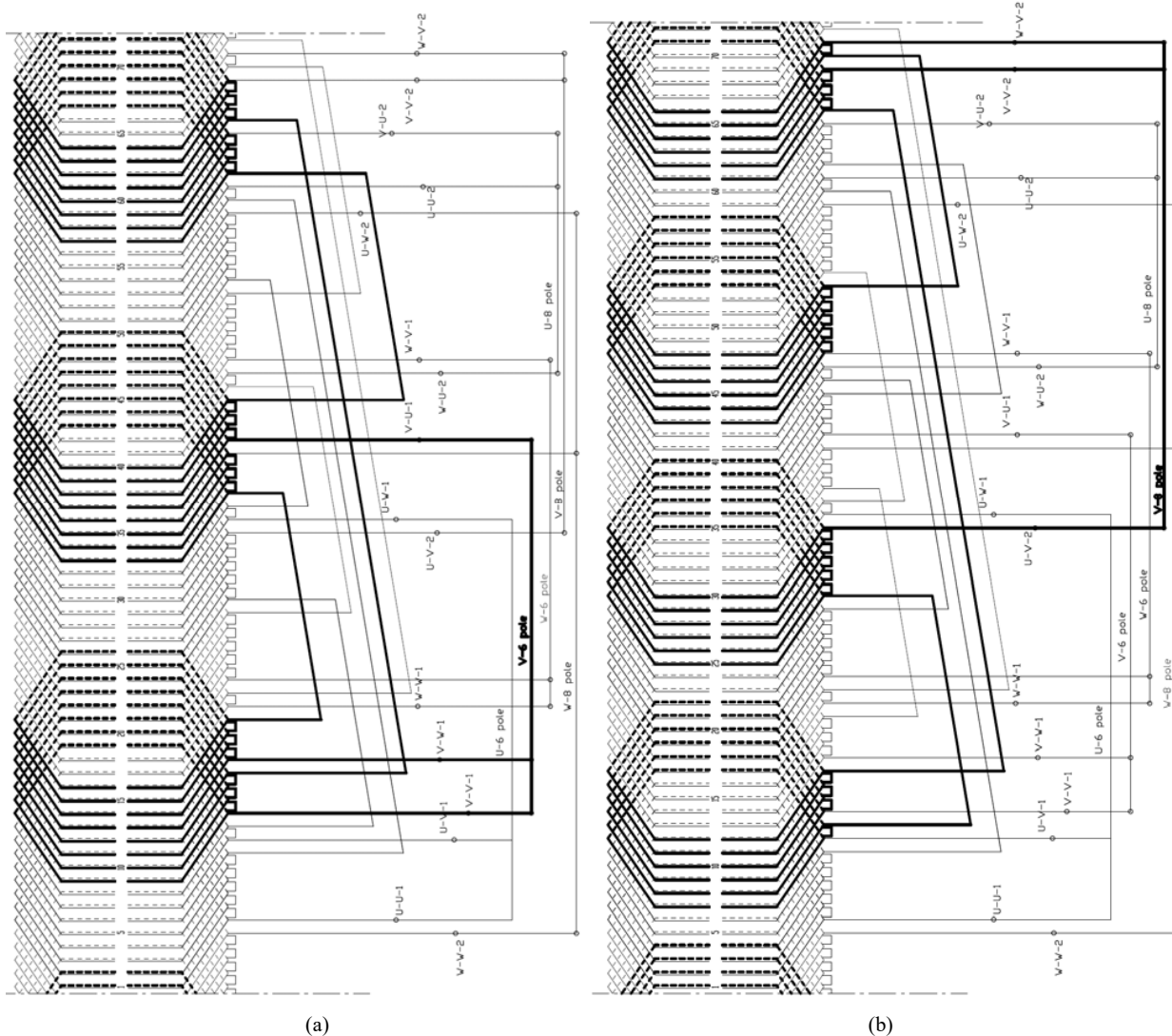

Fig. 3 Winding picture when supplied on the terminals marked by (a) 6 pole, (b) 8 pole

If the designer follows a strict, logical way when subdividing the winding into groups, being obviously smaller than q_6 and q_8 respectively on either pole number, the regrouping is a very easy and simple task. Using this approach, any pole ratio can be implemented by the 3//Y / 3//Y method with no limitation. Endwinding connections are “longer” than those of usual single speed motors but note that each of them shall be dimensioned on the 1/3 of rated current only.

B. Design Aspects

Let us consider now the possible stator slot numbers for this

method. Because the slots are grouped into nine groups, the slot numbers must be integer multiple of 9, no matter which are the pole combinations.

The best is to apply the rule for slot numbers in case of two independent windings [4]. Three-phase motor slot numbers are always integer multiple of 3. Slot numbers possible generally for pole changing motors with two independent windings are integer multiple of a further coefficient of 3 if any of the pole numbers is integer multiple of 6, so the slot numbers suitable for pole changing winding will be integer multiple of 9 in such cases. For the rest of combinations like 8 – 10, 10 – 14, 14 – 16, etc., that slot number must be multiplied by 3. So is the

process for the 3Y /3Y method as well.

In the example of Fig. 3, we go a bit deeper into the design of the motor.

Let us start with the main tool for the designer having in hand: the winding pitch. Fig. 3 (a) shows the arrangement for the lower pole number, whereas Fig. 3 (b) for the higher pole number. In case of pitch 1 - 13 the arrangement is symmetrical, that is no even harmonic, on the lower pole number: the consecutive poles (N - S ...) are equal. The pitch is for 6-pole 180° so called full pitch. It is clear at the first glimpse that the picture of the higher pole number cannot be symmetrical *at the same time*. In this case, pitch is 240° for the 8-pole, therefore (considerable) even harmonics will evolve. If the slot pitch is, however, not 1 - 13 but 1 - 10, the situation is just the opposite: the winding of 8 pole is symmetrical (= no even harmonic) and 6-pole is (extremely) not symmetrical. If the pitch is in between, like 1 - 11 as on Fig. 3, both are non-symmetrical on a moderate extent. It is not usual to choose a pitch over 180° for a 60° phase belt winding; but this value is often exceeded at such pole-changing winding for the higher pole number.

The right choice of pitch is the key in designing such pole-changing motor. Here the actual drive and operation must always be taken into consideration. For example, if the higher pole number, that is lower rated speed, is applied only for starting and the standard operation always occurs on the lower pole number, then selecting a pitch which is symmetrical on the lower pole number (= higher operating speed) is recommended.

Following considerations will help in the decision:

Max. 2nd harmonic will evolve: pitch degree 270°

Disappearing 2nd harmonic: pitch degree 180°

Max. 4th harmonic will evolve: pitch degree 135° or 225°

Disappearing 4th harmonic: pitch degree 180° or 270°

Based on this, we shall choose a pitch that gives a degree between 135° and 225° on both pole numbers. This is possible for pole numbers being "close" to each other, e.g. 6 - 8, 10 - 12, etc.. On those pole numbers which are "far" from each other as 4 - 6, 6 - 10, only those pitches are possible where the pitch degree for the lower pole number is between 135° and 180° and the pitch degree for the higher pole number is over 225° . Vicinity of 225° , however, must be avoided in any case.

Even harmonics are not desirable, therefore it is a must to calculate both main consequences: asynchronous parasitic torques during starting (torque vs. speed) and influence on the differential leakage. Knowing the complete picture, the final decision regarding pitch can be made.

From parasitic torque point of view the 4th harmonic is the critical one, because its rotation is in the motor range, in other words the sense of rotation is the same as that of the fundamental field. The 2nd harmonic is rotating opposite sense therefore it has no influence in the motor range unless its break-down torque is extremely high and its effect (although acting in brake-range) reaches the motor range. Anyway, harmonics' torque may be reduced linearly by reducing magnetizing reactance (= increasing no-load current) see [6] p.

112, equ (240a): which may be a reasonable compromise. 4th harmonic torque has less effect at a drive with parabolic counter-torque like pump, fan etc. Corresponding effect on motor derating $k3$ is discussed under chapter F. Derating.

From differential leakage point of view, however, the 2nd harmonic is the critical one, because its influence on the differential leakage may be dramatic, as discussed more in details below, under chapter D. Therefore, for example, pitch degree of 270° is not recommended, although 4th harmonic would disappear but 2nd harmonic is just on maximum.

Calculations show that

- 1) if the pole numbers are "close" to each other e.g. 6 - 8, 10 - 12 pole, the influence of the even harmonics is minor
- 2) if the pole numbers are "far" from each other e.g. 4 - 6, 6 - 10-pole, the influence of the even harmonics is stronger and requires more careful design.

In case of critical situation regarding too high 4th harmonic, we can apply the following method: we leave the "last" slot or slots in each phase belt without winding. By doing so the phase belt will be less than 120° , or with other words, it gets one-step closer to phase belt 90° . If 90° phase belt were reached, there would be no 4th harmonic - as known from the theory.

Obviously, each "empty" slot requires further derating of the motor, therefore just a moderate use of this method is recommended (see $k4$ under chapter F. Derating.). Calculations show that practically no change of differential leakage is expected here.

C. Parallel Connection of the Winding

For high power motors, further parallel connection of the winding may become necessary. It is, unfortunately, not possible for the smallest pole numbers, e.g. for 6-8 pole or such. It is possible, however, for higher pole numbers: for 12-16 pole further 2 connections, for 18-24 pole further 3// connections become possible, for example.

D. Electromagnetic Calculation: Differential Leakage, Harmonic Attenuation

For electromagnetic calculations, the usual final formulas are not suitable to apply because those are based on odd harmonics only. There is no other choice but to return to the original definition and the original complete calculation method. Winding factors shall be calculated for even harmonics as well, and then the even harmonics shall be included into the summation for both differential leakage and harmonic attenuation. For details, see any basic work on the theory like [1], [2], and [6] and others.

Differential leakage will increase sometimes dramatically; but at the same time attenuation factor will decrease. Reason for this is that although low order even harmonics may reach considerable value, but at the same time, these are the ones most attenuated. Therefore, low order even harmonics may not be so dangerous - *from this point of view*; but their harmonic torques remain and therefore these (e.g. the harmonic torques) are the basic values to be evaluated for the right design of such motors to find the right winding pitch.

E. Magnitude of Torque on Both Pole Numbers

The break-down torque and starting current absolute value is roughly the same on both pole numbers. Since not only the turns per slot but also the connection on both pole numbers are determined, the designer has no freedom in this respect, he has no influence on the ratio of break-down torques between the pole numbers.

F. Necessary Derating of the Basic One-Speed Motor

Based on the above considerations we can now define the necessary derating of such double-speed motor compared to the basic single-speed motor. To put it differently: considering a certain size of a single-speed motor with P [MW] power and $2p_1$ pole number, what can be the power P_1 of such double-speed motor with the same lower pole number $2p_1$. P_2 belonging to $2p_2$ (the higher one) is not important, because the load at the higher pole number is always considerably lower.

We actually find 4 factors for necessary derating:

$$P_1 = k_1 \cdot k_2 \cdot k_3 \cdot k_4 \cdot P \quad (1)$$

Each coefficient is < 1 , according to the followings:

- k1. derating due to the ratio of the winding factor for 60° and 120° belt and for the pitch. The belt factor ratio is always the same: $0.827 / 0.955 = 0.866$ which is the value of inherent derating necessity derived directly from the theory of this method. Then, this should be multiplied by the ratio of the actual (lower pole number) pitch shortening factor compared to the usual $5/6$ shortening factor. This later ratio is usually again less than 1.
- k2. derating due to excess loss caused by the balancing currents due to unbalance of stator phase angles. This only applies in case the lower pole number is not integer multiple of 6, otherwise $k_2 = 1$
- k3. derating necessity due to eventual excess loss caused by eventual necessity of increasing no-load current, which causes the rated current to increase because of decreased $\cos\phi$. For details see D. Design aspects.
- k4. derating necessity in case where phase belt should be less than 120° , again see D. Design aspects

Overall derating necessity is expected to be 75 – 80% (example: a 6 MW single speed motor size may be loaded by 4.5 – 4.8 MW if wound by $3//Y / 3//Y$).

IV. CONSIDERATIONS FOR POLE RATIO OVER 2

A. General Considerations

So far, we have considered motors with pole ratio (much) less than 2: this is the general need in the industry. To make our study complete, however, we shall investigate motors with pole numbers (very) far from each other, like 1:2 (Dahlander) or over. The easiest investigation involves a 1: N ratio of pole numbers where N is an integer.

If N is even, such as 2, 4, 8, etc. and symmetrical pitch (=full pitch) is chosen on the lower pole number, there will be no excitation on the higher pole number (it is easy to understand that U and $-U$ are in the same slot and therefore

magnetomotive force of each slot is zero). As a consequence, such motor simply does not work. If the pitch is modified, the motor will work, but even harmonics will evolve as before.

If N cannot be divided by 3 such as 4, 5, 7, 8 etc. the $3//$ connection cannot be implemented at all, because the 3 groups cannot be identical, as one phase is always and considerably different from both the other phases.

If $N = 3$ (3, 9 etc.), however, like a 6 – 18 pole changing winding, the result is absolute ideal, no even harmonic will appear on either pole number, therefore the motor's behaviour on both pole numbers is identical to the corresponding single-speed motor. The usual method for electromagnetic calculation may be applied, no further scientific considerations are needed. See Fig. 6 for principle.

Based on the principle of Fig. 6, we can create the winding pattern for 1:3 pole ratio (Fig. 4 (a)) and for 1:6 pole ratio (Fig. 4 (b)). On the same way we can continue to create the slot distribution and winding pattern for 1:9, 1: 12 ...etc. pole ratio as well. However, further investigation shows that in such cases ($N=3$, $N=6$ etc.), phase asymmetry will appear again, namely a different kind of asymmetry than that discussed in Paragraph III. B Design aspects. This phase asymmetry is so high for the lower pole number that a solution must be found to eliminate it.

B. Specific Considerations for 1:3, 1:6 ... Pole Ratio

Let us discuss Fig. 6 again. It shows not only the complete upper layers but partly indicates the lower layers as well. Let us compare Fig. 6 for 6 pole upper layer and Fig. 4 (a) for 6 pole connections. Group I. contains always the "beginning part" of the pole, group II. the "middle part", group III. the "last part". If we supply – the parallel connected – group I, group II and group III. with the same 3-phase system, then considerable balancing currents will be generated exceeding any tolerance range.

In order to avoid balancing currents, we shall do the following: we shall supply

- group I. by a 3-phase system $-40^\circ - 80^\circ - 200^\circ$
- group II. by a 3-phase system $0^\circ - 120^\circ - 240^\circ$
- group III. by a 3-phase system $40^\circ - 160^\circ - 280^\circ$.

If not, phase difference as high as 40° between both U & V and V & W will drive the balancing currents. To avoid this, the supplying 3-phase systems shall be shifted for each group by 40° . If not, phase difference as high as 40° between both U & V and V & W will drive the balancing currents. To avoid this, the supplying 3-phase systems shall be shifted for each group by 40° : what we have reached in this way is just a clear 9-phase system. Consequently, the only possibility for avoiding balancing currents in pole numbers $2p - 3x2p$ or $2p - 6x2p$, etc. is to have nine terminals for the lower pole number.

For creating 9-phase system, frequency converters may be used. The converter is connected into 3-parallel and the regulation of each parallel branch is shifted by 40° from each other. As a consequence, no any further derating other than k1 is necessary in case of 1:3 (1:9 etc.) pole combination. Such shifting of 40° is not necessary for the higher pole number, which may thus preserve its 3-phase winding – 3-phase supply

– 3-terminal. When changing the supply to the higher pole number, the nine terminals of the lower pole number (always

3-3-3 of the same phase) must be short circuited by a separate switch.

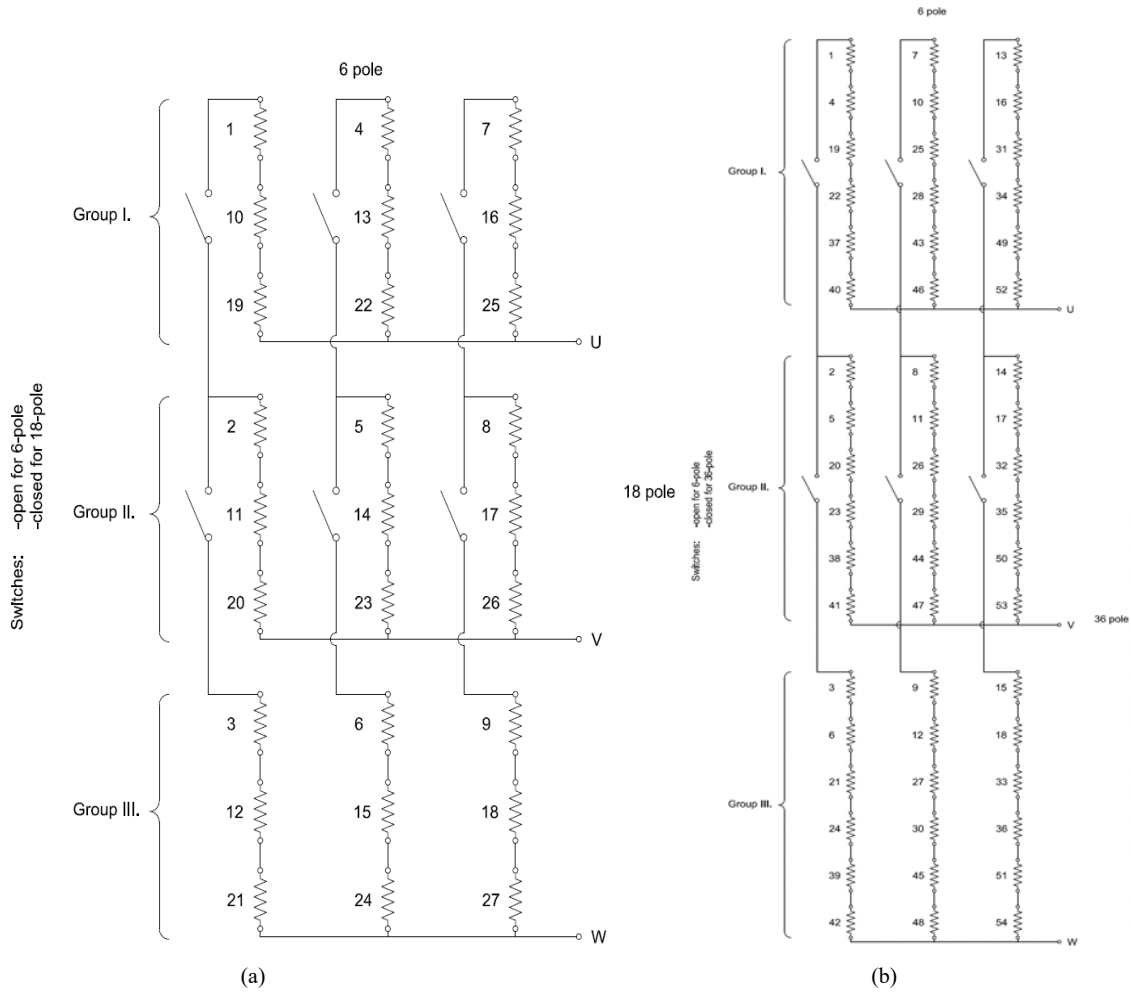

Fig. 4 Pole changing winding for (a) 1:3 pole ratio, (b) 1:6 pole changing ratio

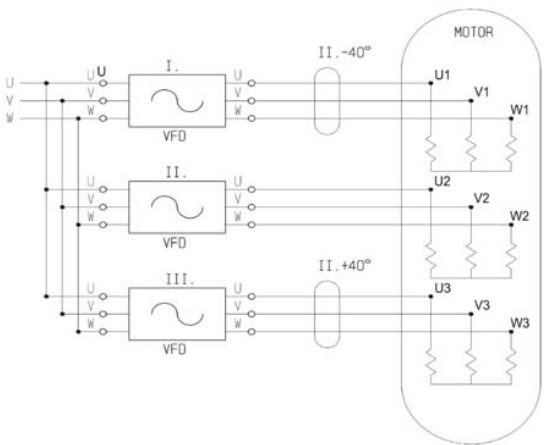

Fig. 5 (a) Proposal for supply of the stator winding on the lower pole number (see "MOTOR" details on Fig. 5 (b))

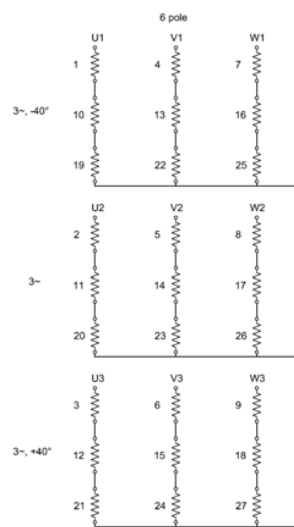

Fig. 5 (b) Details of Fig. 5 (a) "MOTOR"

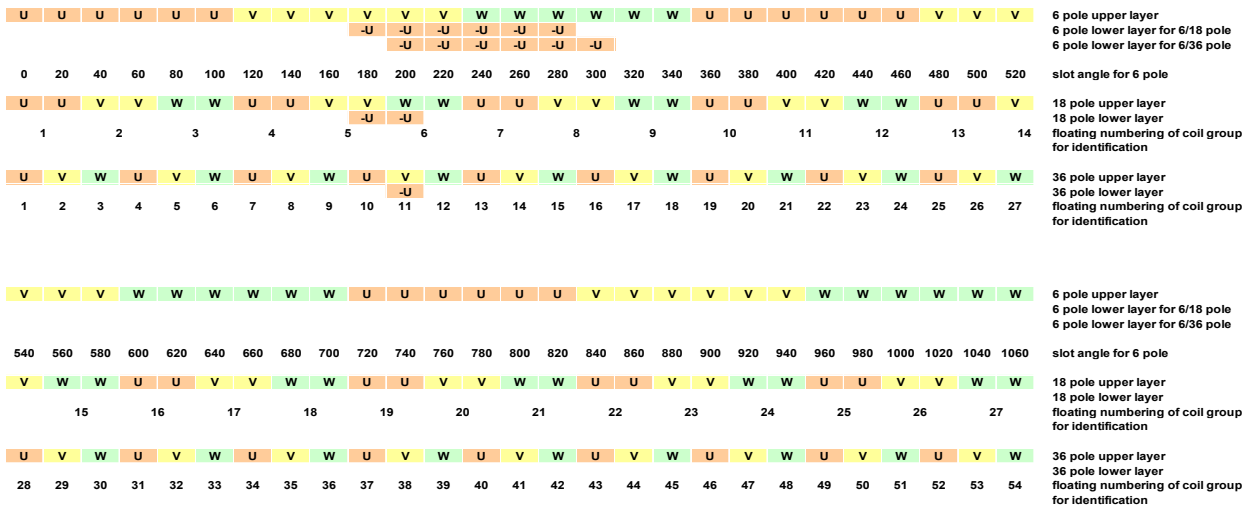

Fig. 6 Slot distribution pattern for 1:3 as well as for 1:6 pole ratio

The result might seem to be of little sense, even against the design goal of typical industry motors, as it was discussed in I. Introduction. But, what we have found helps us to conceptualize the ideal driving system of very high power motors for main naval propulsion application where greatly different speeds are required, such as cruising speed and manoeuvring speed and the speed regulation of the driving – also if not single speed but pole changing motors are applied – is carried out by frequency converter [5]. Figs. 5 (a) and (b) show the complete energy supply concept for the lower pole number.

We apply the same energy supply concept for the lower pole number in case of 6-36 pole, 6-54 pole etc. that means for 1:6, 1:9, etc. pole ratio as well.

Mechanical pitch corresponds always to the one of the lower pole number.

C. Further Extension of the Approach: 1:4, 1:5, 1:7... Pole Ratio

We have always investigated a motor winding supplied by the usual 3-phase network so far. Therefore some limitations have appeared, such that 1:4, 1:5, 1:7 etc. ratios have not been possible. If we extend, however, the number of the phases, those missing pole ratios became possible immediately. 1:4 pole ratio is possible to achieve by 4-phase supply and 4//Y / 4//Y connection, 1:5 pole ratio by 5-phase supply system and 5//Y / 5//Y connection, 1:7 pole ratio by 7-phase supply system and 7//Y / 7//Y connection and so on.

Some conclusions found before remain still valid. Supply concept on the lower pole number must be applied similarly to Fig. 5 (a), because all the considerations regarding balancing currents under B, Specific considerations ... shall still be applied. Further, what we have found before for the case if N is even or odd, is still valid. If N is even, like 1:4, even harmonics will appear. If N is odd like 1:5, 1:7 etc. *the result again is absolute ideal, no even harmonic will appear on either pole number, therefore the motor's behaviour on both pole numbers is identical to the corresponding single-speed*

motor. As a consequence, however, the number of the terminals will increase according to the number of the phases.

V. CONCLUSION

In this paper, a complete and comprehensive analysis of 3Y/3Y pole changing method has been provided including application, characteristics and design aspects for high power motors.

The main findings of the analysis are that the method is well suitable, is even of advantage for high power application, it is applicable even for 1:3 pole ratio allowing to conceptualize a complete drive system (for main naval propulsion) and finally allows the (theoretically infinite) extension for 1:6, 1:9, 1:12 etc. pole changing ratio.

REFERENCES

- [1] W. Nürnberg, "The asynchronous machine" – Die Asynchronmaschine, Springer Verlag 1952. p.299.
- [2] Liska József, "Electrical Machines IV. Asynchronous Machines" – Villamos gépek, IV. Aszinkron gépek, Tankönyvkiadó Budapest 1960. p. 126.
- [3] Dawei Meng, Qian Wang: Research on Balanced Winding Used in 3Y/3Y pole changing Motor, - *International Journal of Automation and Power Engineering (IJAPE)* Volume 2 Issue 4, May 2013.
- [4] Lengyel Zoltán, "Modern pole-changing motors with two independent windings", "Korszerű kététekereslészű motorok", *Ganz Közlemények* 1964. p. 31 – 36.
- [5] Stephen B. Kuznetsov, D.I.C., Ph.D., P.E., "Advanced Pole-Amplitude-Modulated Induction Machinery for Main Naval Propulsion" – publishing entity is unknown to the Author.
- [6] Bedrich Heller, Václav Hamata, "Harmonic Field Effects in Induction Machines", *ELSEVIER Scientific Publishing Company* Amsterdam, Oxford, New York 1977.
- [7] G. H. Rawcliff, B. V. Jayawant, "The development of a new 3: 1 pole-changing motor". *Proceedings of the IEE – Part A Power Engineering* 1956. p. 306 – 316.
- [8] Umesh B S, Kiran Kumar N, Sivakumar K, "Performance improvement of a nine phase pole phase modulated induction motor drive". *IEEE International Conference on Industrial Technology*, 2015. p.812-817.



Gábor Kovács was born on January 5th 1949. in Budapest, Hungary. He received his Engineering Degree at the Hungarian Technical University Budapest, Hungary in 1972., in the field of Heavy Current Industry, for Electrical Machines.

He joined to the Ganz Electric Works, Budapest, Hungary immediately after, he has been working there ever since. The name of the company has been changed a couple of times since then. His working place has been the Department for Electromagnetic Calculation of Induction Motors; after some time he became the Head of the Department, today he is a consultant engineer there. He was regular participant of the ICEM Conferences in the 80s with his invention "Squirrel cage induction motor with starting disc". Today he is dealing with pole changing windings.