

Mathematical Modeling of the Working Principle of Gravity Gradient Instrument

Danni Cong, Meiping Wu, Hua Mu, Xiaofeng He, Junxiang Lian, Juliang Cao, Shaokun Cai, Hao Qin

Abstract—Gravity field is of great significance in geoscience, national economy and national security, and gravitational gradient measurement has been extensively studied due to its higher accuracy than gravity measurement. Gravity gradient sensor, being one of core devices of the gravity gradient instrument, plays a key role in measuring accuracy. Therefore, this paper starts from analyzing the working principle of the gravity gradient sensor by Newton's law, and then considers the relative motion between inertial and non-inertial systems to build a relatively adequate mathematical model, laying a foundation for the measurement error calibration, measurement accuracy improvement.

Keywords—Gravity gradient, accelerometer, gravity gradient sensor, single-axis rotation modulation.

I. PREFACE

EACH gravity field is a kind of cohesive field formed by the superposition of the Earth's gravitational field and centrifugal force field. Gravity field information has important applications in geodesy, geophysical science, seismic analysis, earth exploration, inertial navigation, etc. [1]-[4]. There are many ways to obtain gravitational fields. Gravity measurements usually use gravimeters, but the accuracy and resolution of gravimetric measurements are far from meeting the requirements of exploration geophysics. The gravitational gradient meter can measure the second order derivative of the gravitational force; that is, has a higher resolution than the gravimeter. At the same time, the gravitational gradient is a measure of the rate of change of the spatial gravity field, which is less affected by the acceleration of the motion carrier [5]. Therefore, at the beginning of this century, the gravity gradient instrument was introduced into the field of resource exploration, and the gradient measurement method has also been extensively studied. The performance of traditional measurement method is poor, while the superconductivity and atomic technology exploration are beyond practical applications [6]-[8]. In this paper, the mathematical model of the method is used to analyze the input and output relations of the accelerometer according to the measurement principle, and the gradient component measurement equation is obtained, laying the foundation for the work in further mechanical

Danni Cong is with the National University of Defense Technology, Institute of Electromechanical Engineering and Automation, Changsha, Hunan, China (phone: 13555963935; e-mail: hennessydlut@163.com).

Meiping Wu is with the National University of Defense Technology, Institute of Electromechanical Engineering and Automation, Changsha, Hunan, China (e-mail: meipingwu@263.net).

Hao Qin is with the National University of Defense Technology, Institute of Electromechanical Engineering and Automation, Changsha, Hunan, China (phone: 17667172935; e-mail: 854889990@qq.com).

precision design, physical design, measurement and extraction of the signal.

II. CONCEPTION OF GRAVITY GRADIENT REVIEW STAGE

The physical meaning of the gravitational gradient is used to describe the change in the gravity component due to the position, and the gravitational gradient is the second derivative of the gravitational force,

$$\begin{aligned} g_x(r + \delta r) &= g_x(r) + \frac{\partial^2 W}{\partial x^2} \delta x + \frac{\partial^2 W}{\partial y \partial x} \delta y + \frac{\partial^2 W}{\partial z \partial x} \delta z \\ &= g_x(r) + \Gamma_{xx} \delta x + \Gamma_{yx} \delta y + \Gamma_{zx} \delta z \end{aligned} \quad (1)$$

where Γ is the gravity gradient tensor:

$$\Gamma = \begin{bmatrix} \Gamma_{xx} & \Gamma_{yx} & \Gamma_{zx} \\ \Gamma_{xy} & \Gamma_{yy} & \Gamma_{zy} \\ \Gamma_{xz} & \Gamma_{yz} & \Gamma_{zz} \end{bmatrix} = \begin{bmatrix} \frac{\partial^2 W}{\partial x^2} & \frac{\partial^2 W}{\partial y \partial x} & \frac{\partial^2 W}{\partial z \partial x} \\ \frac{\partial^2 W}{\partial x \partial y} & \frac{\partial^2 W}{\partial y^2} & \frac{\partial^2 W}{\partial z \partial y} \\ \frac{\partial^2 W}{\partial x \partial z} & \frac{\partial^2 W}{\partial y \partial z} & \frac{\partial^2 W}{\partial z^2} \end{bmatrix} \quad (2)$$

There are nine components of the gravity gradient tensor:

$\begin{bmatrix} \Gamma_{xx} & \Gamma_{yx} & \Gamma_{zx} \\ \Gamma_{xy} & \Gamma_{yy} & \Gamma_{zy} \\ \Gamma_{xz} & \Gamma_{yz} & \Gamma_{zz} \end{bmatrix}$, among them Γ_{xx} represents for the g_x space rate of change in x direction, Γ_{xy} represents for the g_x space rate of change in y direction.

$$\Gamma_{xy} = \Gamma_{yx}, \Gamma_{yz} = \Gamma_{zy}, \Gamma_{zx} = \Gamma_{xz} \quad (3)$$

Outside the earth, as the gravitational potential is continuous and limited everywhere, gravity potential meets the Laplace equation:

$$W_{xx} + W_{yy} + W_{zz} = 0 \quad (4)$$

In summary, it is only necessary to solve any five independent values in the second derivative of the gravitational bit to obtain the full gradient information.

III. GRAVITY GRADIENT MEASUREMENT METHOD AND UNIAXIAL ROTATION MODULATION CONCEPT

Assume that the gravity of two accelerometers, being Δl apart from each other, are g_1, g_2 , respectively. Thus, the gravity of them as the following relationship:

$$g_2 = g_1 + \frac{\partial g_1}{\partial \Delta l} \Delta l \tag{5}$$

As the signal of earth's gravity gradient is extraordinarily weak, the accuracy of the existing accelerometer, however, cannot meet the requirements of that of a gravity gradient meter. Assume that the measurement accuracy is 10E, then the gravity difference of two points, being 10 cm away from each other, should be measured by accelerometers with accuracy of $10^{-10}g$ [9]. Therefore, in order to achieve the goal of measuring the weak gravitational gradient signal without improving the accuracy of the accelerometer, Bell Aerospace Textron Company in the United States uses the concept of rotary accelerometer, breaking the performance limits of a single component. The product developed by the company and an Australian one together has been successfully put into use [3], and rotary accelerometer gravimeter is currently the only successful practical application, suitable for airborne and shipborne gradient measuring instruments [10].

The Gravity Gradient Instrument (GGI), shown in Fig. 1 is a sensitive gravity gradient sensor. GGI is composed of two pairs of rotating symmetrical and orthogonal high-precision accelerometer, installed on the turntable. Based on the existing accelerometer, the use of rotary modulation technology has further improved the accuracy of the gravity gradient, through the rotation of the disk.

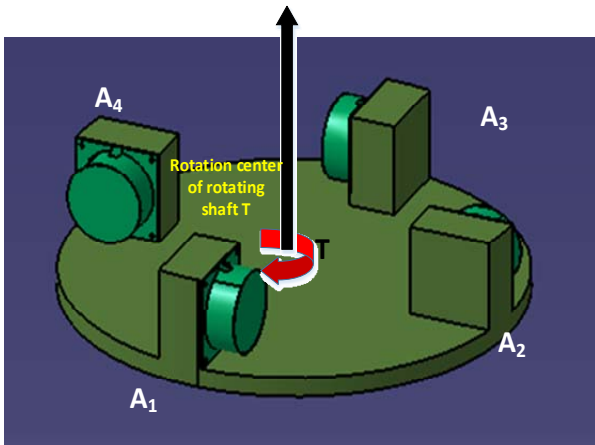

Fig. 1 Basic structure of the gravity gradient instrument

IV. MATHEMATICAL MODEL OF THE WORKING GGI

A. Force Analysis of GGI

According to Taylor's expansion:

$$\begin{aligned} a_{1x} &= a_{0x} + \Gamma_{xx} \Delta x + \Gamma_{xy} \Delta y = a_{0x} + \Gamma_{xx} r \cos \omega t - \Gamma_{xy} r \sin \omega t \\ a_{1y} &= a_{0y} - \Gamma_{yy} \Delta y + \Gamma_{yx} \Delta x = a_{0y} - \Gamma_{yy} r \sin \omega t + \Gamma_{yx} r \cos \omega t \\ \Gamma_{xy} &= \Gamma_{yx} \end{aligned} \tag{6}$$

where r is the distance between the accelerometer and the center of the rotating disk, and a_{1x} while a_{0x} is the accelerate of the center point of the disk in x-direction. The rotating speed is ω , thus, ωt is the angle rotated by accelerometer one.

The specific force output by the accelerometer one is f_1 :

$$\begin{aligned} f_1 &= -a_{1x} \sin \omega t - a_{1y} \cos \omega t = -a_{0x} \sin \omega t - a_{0y} \cos \omega t \\ &+ r(\Gamma_{yy} - \Gamma_{xx}) \sin \omega t \cos \omega t + \Gamma_{xy} r (\sin \omega t)^2 - \Gamma_{yx} r (\cos \omega t)^2 \end{aligned} \tag{7}$$

The output equations of the four accelerometers are:

$$\begin{aligned} \overline{a_1} \bullet \overline{v_1} &= -a_{0x} \sin \omega t - a_{0y} \cos \omega t \\ &- \frac{1}{2} r (\Gamma_{xx} - \Gamma_{yy}) \sin 2\omega t - \Gamma_{xy} r \cos 2\omega t \\ \overline{a_3} \bullet \overline{v_3} &= a_{0x} \sin \omega t + a_{0y} \cos \omega t \\ &- \frac{1}{2} r (\Gamma_{xx} - \Gamma_{yy}) \sin 2\omega t - \Gamma_{xy} r \cos 2\omega t \\ \overline{a_2} \bullet \overline{v_2} &= a_{0x} \cos \omega t + a_{0y} \sin \omega t \\ &+ \frac{1}{2} r (\Gamma_{xx} - \Gamma_{yy}) \sin 2\omega t + \Gamma_{xy} r \cos 2\omega t \\ \overline{a_4} \bullet \overline{v_4} &= -a_{0x} \cos \omega t - a_{0y} \sin \omega t \\ &+ \frac{1}{2} r (\Gamma_{xx} - \Gamma_{yy}) \sin 2\omega t + \Gamma_{xy} r \cos 2\omega t \end{aligned} \tag{8}$$

where ωt belongs to accelerometer one while that of number two, three and four are $\omega t + \frac{\pi}{2}$, $\omega t + \pi$, and $\omega t + \frac{3\pi}{2}$, respectively.

The following equations tell the relationship between the direction vectors of the sensitive axis $\overline{v_1}, \overline{v_2}, \overline{v_3}, \overline{v_4}$:

$$\begin{aligned} \overline{v_1} &= [-\sin \omega t \quad -\cos \omega t \quad 0] \\ \overline{v_3} &= [\sin \omega t \quad \cos \omega t \quad 0] = -\overline{v_1} \\ \overline{v_2} &= [-\cos \omega t \quad \sin \omega t \quad 0] \\ \overline{v_4} &= [\cos \omega t \quad -\sin \omega t \quad 0] = -\overline{v_2} \end{aligned} \tag{9}$$

Make a combination and the result leads to the components of the gravity gradient:

$$\begin{aligned} & ((\bar{a}_1 \bullet \bar{v}_1 + \bar{a}_3 \bullet \bar{v}_3) - (\bar{a}_2 \bullet \bar{v}_2 + \bar{a}_4 \bullet \bar{v}_4)) \\ & = -2r(\Gamma_{xx} - \Gamma_{yy}) \sin 2\omega t - 4r\Gamma_{xy} \cos 2\omega t \end{aligned} \quad (10)$$

B. Mathematical Model of the Working Principle

Although the rotational accelerometer gravity gradient instrument is based on the same principle, differences in the mathematical working model are derived in literature [8], [11]-[14]. That the measurement model is perfect or not, is a serious influence on the accuracy of the measurement, as the gradient signal is extraordinarily weak. Strictly speaking, the platform system of the gravity gradient sensor, the carrier system and even the earth, are not the inertial coordinate system. In this paper, force analysis between the inertial and

non-inertial systems is taken into consideration, as well as the tested acceleration and the actual gradient values of the disc center to establish the correlation model. Therefore, a more complete measurement model comes into conclusion, laying a good foundation for error model analysis, mechanical precision design, and the derivation of carrier platform stability requirements.

Based on the kinetic force analysis, the block of accelerometer moves from N to B at the equilibrium position when the spring force and the damper resistance are zero, and the internal structure is shown in Fig. 1. In this moment, the spring force is balanced to the inertial force, and also by the universal gravitation.

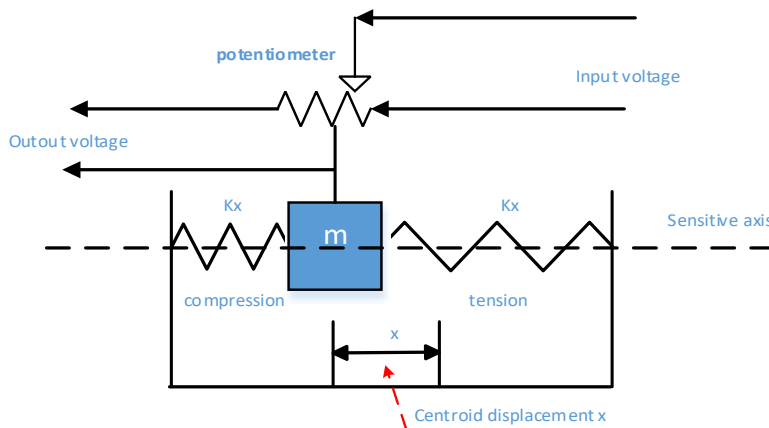

Fig. 2 Basic structure of the accelerometer

Get the following equation after the force analysis of the block:

$$m\bar{a} = \bar{U} - \left(c \frac{d\bar{s}_{BN}}{dt} + 2k\bar{s}_{BN} \right) \quad (11)$$

\bar{s}_{BN} is the displacement from non-balance position to the balance position, c, k, m are the coefficient of damping, elasticity, and mass of the block. In the inertial frame of reference I \bar{s}_{IN} is the relative displacement, thus \bar{a} can be expressed as:

$$\bar{a} = \frac{d^2}{dt^2}(\bar{s}_{IN}) \quad (12)$$

The block is in its balance position, when the testing result is displays:

$$m \frac{d^2 \bar{s}_{BN}}{dt^2} = c \frac{d}{dt} \bar{s}_{BN} \quad (13)$$

deriving the expression of the output of the accelerometer is:

$$\bar{a} = -\frac{2k\bar{s}_{BN}}{m} \quad (14)$$

Ignoring all the other forces outside the earth, get the gradient by considering the actual gravity of the center of the disk:

$$\frac{\bar{U}}{m} = \bar{g}_0 + \Gamma \bullet \bar{s}_{TB} \quad (15)$$

\bar{s}_{TB} points from T to B, \bar{g}_0 is actual gradient of the center of the disk.

To derive the relationship between the real gradient value and the measurement result of accelerometer, the key point is to establish a model that contains the relative acceleration, the centripetal acceleration, and the Coriolis force of the coordinate systems. In order to facilitate the establishment of the force model between the relevant systems, the geocentric coordinate system E, the carrier platform coordinate system P, the gravity gradient sensor turntable coordinate system T, the accelerometer static coordinate system S, and the detection mass coordinate system are M. Dissolve the displacement of the block relative to the inertial coordinate system:

$$\overline{s}_{IN} = \overline{s}_{IE} + \overline{s}_{EP} + \overline{s}_{PT} + \overline{s}_{TB} + \overline{s}_{BN} \quad (16)$$

The decomposition for the rest terms is as following:

$$\begin{aligned} \frac{d^2}{dt^2}(\overline{s}_{IE} + \overline{s}_{EP} + \overline{s}_{PT} + \overline{s}_{TB}) &= \frac{d^2 \overline{s}_{IE}}{dt^2} + \frac{d^2 \overline{s}_{EP}}{dt^2} + \frac{d^2 \overline{s}_{PT}}{dt^2} + \frac{d \overline{\omega}_p}{dt} \times \overline{s}_{PT} \\ &+ \frac{d \overline{\omega}_T}{dt} \times \overline{s}_{TB} + \frac{d \overline{\omega}_p}{dt} \times \overline{s}_{TB} + \overline{\omega}_E \times (\overline{\omega}_E \times \overline{s}_{EP}) \\ &+ \overline{\omega}_E \times (\overline{\omega}_E \times \overline{s}_{PT}) + \overline{\omega}_p \times (\overline{\omega}_p \times \overline{s}_{PT}) \\ &+ \overline{\omega}_T \times (\overline{\omega}_T \times \overline{s}_{TB}) + \overline{\omega}_p \times (\overline{\omega}_p \times \overline{s}_{TB}) \\ &+ \overline{\omega}_E \times (\overline{\omega}_E \times \overline{s}_{TB}) + 2 \overline{\omega}_p \times \frac{d \overline{s}_{PT}}{dt} \\ &+ 2 \overline{\omega}_E \times \frac{d \overline{s}_{EP}}{dt} + 2 \overline{\omega}_E \times \frac{d \overline{s}_{PT}}{dt} + 2 \overline{\omega}_E \times (\overline{\omega}_p \times \overline{s}_{PT}) + 2 \overline{\omega}_p \times (\overline{\omega}_T \times \overline{s}_{PT}) \\ &+ 2 \overline{\omega}_E \times (\overline{\omega}_T \times \overline{s}_{TB}) + 2 \overline{\omega}_E \times (\overline{\omega}_p \times \overline{s}_{TB}) \end{aligned} \quad (17)$$

$\overline{\omega}_E, \overline{\omega}_p, \overline{\omega}_T$ are the angular velocity of earth autorotation, carrier platform, and the disk of the sensor.

Above all, comes the relationship between $\overline{a}_0, \overline{g}_0$ and the output of the accelerometer.

$$\begin{aligned} \overline{a} &= \overline{a}_0 + \frac{d(\overline{\omega}_T + \overline{\omega}_p)}{dt} \times \overline{s}_{TB} + (\overline{\omega}_T + 2 \overline{\omega}_p) \times (\overline{\omega}_T \times \overline{s}_{TB}) \\ &+ \overline{\omega}_p \times (\overline{\omega}_p \times \overline{s}_{TB}) + 2 \overline{\omega}_E \times (\overline{\omega}_T \times \overline{s}_{TB}) \\ &+ 2 \overline{\omega}_E \times (\overline{\omega}_p \times \overline{s}_{TB}) + \overline{\omega}_E \times (\overline{\omega}_E \times \overline{s}_{TB}) - (\overline{g}_0 + \Gamma \bullet \overline{s}_{TB}) \end{aligned} \quad (18)$$

$$\begin{aligned} \overline{a}_0 &= \frac{d^2 \overline{s}_{IE}}{dt^2} + \frac{d^2 \overline{s}_{EP}}{dt^2} + \frac{d^2 \overline{s}_{PT}}{dt^2} + \frac{d \overline{\omega}_p}{dt} \times \overline{s}_{TB} + \overline{\omega}_E \times (\overline{\omega}_E \times \overline{s}_{EP}) \\ &+ \overline{\omega}_E \times (\overline{\omega}_E \times \overline{s}_{PT}) + \overline{\omega}_p \times (\overline{\omega}_p \times \overline{s}_{PT}) \\ &+ 2 \overline{\omega}_E \times (\overline{\omega}_p \times \overline{s}_{PT}) + 2 \overline{\omega}_p \times \frac{d \overline{s}_{PT}}{dt} + 2 \overline{\omega}_E \times \frac{d \overline{s}_{EP}}{dt} + 2 \overline{\omega}_E \times \frac{d \overline{s}_{PT}}{dt} \end{aligned} \quad (19)$$

where \overline{s}_{TB} is the vector from the center point of the disk to the center of the block, defined as r .

$$(\overline{s}_{TB})_n = \overline{r}_n (n=1, 2, 3, 4) \quad (20)$$

$$\frac{d(\overline{\omega}_p + \overline{\omega}_T)}{dt} = \overline{\alpha}_p + \overline{\alpha}_T = (\alpha_{PTx}, \alpha_{PTy}, \alpha_{PTz}) \quad (21)$$

The equation above is the sum of the angular accelerate of the platform and the disk.

$$\begin{aligned} \overline{\omega}_E &= (\omega_{Ex}, \omega_{Ey}, \omega_{Ez}) \\ \overline{\omega}_p &= (\omega_{Px}, \omega_{Py}, \omega_{Pz}) \\ \overline{\omega}_T &= (\omega_{Tx}, \omega_{Ty}, \omega_{Tz}) \\ \overline{g}_0 &= (g_{0x}, g_{0y}, g_{0z}) \\ \overline{a}_0 &= (a_{0x}, a_{0y}, a_{0z}) \end{aligned} \quad (22)$$

Substitute into (8),

$$\begin{aligned} \overline{a}_1 \bullet \overline{v}_1 &= -(a_{0x} - g_{0x}) \sin \omega t - (a_{0y} - g_{0y}) \cos \omega t \\ &+ r[\alpha_{PTz} - \omega_{Py} \omega_{Tx} - \omega_{Ey}(\omega_{Px} + \omega_{Tx}) \\ &+ \omega_{Px} \omega_{Ty} + \omega_{Ex}(\omega_{Py} + \omega_{Ty})] - \frac{1}{2} r \sin 2\omega t [\Gamma_{xx} - \Gamma_{yy} \\ &- (\omega_{Ex} - \omega_{Ey} + \omega_{Px} - \omega_{Py} + \omega_{Tx} - \omega_{Ty}) \\ &(\omega_{Ex} + \omega_{Ey} + \omega_{Px} + \omega_{Py} + \omega_{Tx} + \omega_{Ty})] \\ &- r \cos 2\omega t [\Gamma_{xy} - (\omega_{Ex} + \omega_{Px} + \omega_{Tx})(\omega_{Ey} + \omega_{Py} + \omega_{Ty})] \end{aligned} \quad (23)$$

Comes out the output S_{out} :

$$\begin{aligned} S_{out} &= ((\overline{a}_1 \bullet \overline{v}_1 + \overline{a}_3 \bullet \overline{v}_3) - (\overline{a}_2 \bullet \overline{v}_2 + \overline{a}_4 \bullet \overline{v}_4)) \\ &= -4r \cos 2\omega t [\Gamma_{xy} - \\ &(\omega_{Ex} + \omega_{Px} + \omega_{Tx})(\omega_{Ey} + \omega_{Py} + \omega_{Ty})] \\ &+ 2r \sin 2\omega t [\Gamma_{xx} - \Gamma_{yy} - \\ &(\omega_{Ex} - \omega_{Ey} + \omega_{Px} - \omega_{Py} + \omega_{Tx} - \omega_{Ty}) \\ &(\omega_{Ex} + \omega_{Ey} + \omega_{Px} + \omega_{Py} + \omega_{Tx} + \omega_{Ty})] \end{aligned} \quad (24)$$

In the output of the two opposite accelerometers on the gravity gradient sensor turntable, there is a corresponding differential component, of which the affection can be counteracted by each other. The effect of disk rotation is to eliminate the effects of certain noise. The signal is modulated from the triangular wave, of which the frequency is twice the speed of the turntable, and where the gravitational gradient signal can be further demodulated.

V. CONCLUSION

In this paper, the concept of gravity gradient information is introduced in detail, and the mathematical model of the input and output of gradient sensor is established by analyzing the principle of gravity gauging. Each gravitational gradient sensor can demodulate two equations on the gravitational gradient signal. Therefore, by installing three gravitational gradient sensors that orthogonal to each other, can all the components of the gravitational gradient be derived, for six different equations can be demodulated from the signal. This model comprehensively covers the factors that affect the output of the gravity gradient sensor, which lays a foundation for deducing

the measurement error of the gravity gradient sensor and compensate for the error. It is also the basic for proposing the stability of the sensor structure and the stability requirement of the carrier platform.

REFERENCES

- [1] G. O. Young, "Synthetic structure of industrial plastics (Book style with paper title and editor)," in *Plastics*, 2nd ed. vol. 3, J. Peters, Ed. New York: McGraw-Hill, 1964, pp. 15–64.
- [2] W.-K. Chen, *Linear Networks and Systems* (Book style). Belmont, CA: Wadsworth, 1993, pp. 123–135.
- [3] H. Poor, *An Introduction to Signal Detection and Estimation*. New York: Springer-Verlag, 1985, ch. 4.
- [4] B. Smith, "An approach to graphs of linear forms (Unpublished work style)," unpublished.
- [5] E. H. Miller, "A note on reflector arrays (Periodical style—Accepted for publication)," *World Academy of Science Engineering and Technology Trans. Antennas Propagat.*, to be published.
- [6] J. Wang, "Fundamentals of erbium-doped fiber amplifiers arrays (Periodical style—Submitted for publication)," *World Academy of Science Engineering and Technology J. Quantum Electron.*, submitted for publication.
- [7] C. J. Kaufman, Rocky Mountain Research Lab., Boulder, CO, private communication, May 1995.
- [8] Y. Yorozu, M. Hirano, K. Oka, and Y. Tagawa, "Electron spectroscopy studies on magneto-optical media and plastic substrate interfaces (Translation Journals style)," *World Academy of Science Engineering and Technology Transl. J. Magn.Jpn.*, vol. 2, Aug. 1987, pp. 740–741 (*Dig. 9th Annu. Conf. Magnetism Japan*, 1982, p. 301).
- [9] M. Young, *The Technical Writers Handbook*. Mill Valley, CA: University Science, 1989.
- [10] J. U. Duncombe, "Infrared navigation—Part I: An assessment of feasibility (Periodical style)," *World Academy of Science Engineering and Technology Trans. Electron Devices*, vol. ED-11, pp. 34–39, Jan. 1959.
- [11] S. Chen, B. Mulgrew, and P. M. Grant, "A clustering technique for digital communications channel equalization using radial basis function networks," *World Academy of Science Engineering and Technology Trans. Neural Networks*, vol. 4, pp. 570–578, July 1993.
- [12] R. W. Lucky, "Automatic equalization for digital communication," *Bell Syst. Tech. J.*, vol. 44, no. 4, pp. 547–588, Apr. 1965.
- [13] S. P. Bingulac, "On the compatibility of adaptive controllers (Published Conference Proceedings style)," in *Proc. 4th Annu. Allerton Conf. Circuits and Systems Theory*, New York, 1994, pp. 8–16.
- [14] G. R. Faulhaber, "Design of service systems with priority reservation," in *Conf. Rec. 1995 World Academy of Science Engineering and Technology Int. Conf. Communications*, pp. 3–8.

Danni Cong, born in November 1992 in Dalian, Liaoning Province, China. Bachelor degree in Dalian University of Technology, received a bachelor's degree in engineering. And with excellent results were sent to the National Defense Science and Technology University School of Electrical and Mechanical Engineering and Automation to continue their studies.