

# Application of Powder Metallurgy Technologies for Gas Turbine Engine Wheel Production

Liubov Magerramova, Eugene Kratt, Pavel Presniakov

**Abstract**—A detailed analysis has been performed for several schemes of Gas Turbine Wheels production based on additive and powder technologies including metal, ceramic, and stereolithography 3-D printing. During the process of development and debugging of gas turbine engine components, different versions of these components must be manufactured and tested. Cooled blades of the turbine are among of these components. They are usually produced by traditional casting methods. This method requires long and costly design and manufacture of casting molds. Moreover, traditional manufacturing methods limit the design possibilities of complex critical parts of engine, so capabilities of Powder Metallurgy Techniques (PMT) were analyzed to manufacture the turbine wheel with air-cooled blades. PMT dramatically reduce time needed for such production and allow creating new complex design solutions aimed at improving the technical characteristics of the engine: improving fuel efficiency and environmental performance, increasing reliability, and reducing weight. To accelerate and simplify the blades manufacturing process, several options based on additive technologies were used. The options were implemented in the form of various casting equipment for the manufacturing of blades. Methods of powder metallurgy were applied for connecting the blades with the disc. The optimal production scheme and a set of technologies for the manufacturing of blades and turbine wheel and other parts of the engine can be selected on the basis of the options considered.

**Keywords**—Additive technologies, gas turbine engine, powder technology, turbine wheel.

## I. INTRODUCTION

**D**EMAND for higher-performance parts and components (strength, durability, ability to work in hostile environments, and etc.) are constantly rising in various technical fields. This is substantially referred to the field of advanced aircraft turbine engines production which is subject to high (and constantly growing) safety performance, ecological safety and economic efficiency. This triggers the necessity to use new materials, search for new designs, and use new technologies.

One of the main components of gas turbine engines determining their characteristics is the turbine wheels that are operated under high unsteady external loads and temperatures in the process of aircraft maneuvering.

The turbine wheels are traditionally assembled from

Liubov Magerramova is with the Central Institute of Aviation Motors, Aviamotornaya st., Moscow 111116 RF (phone: 07903-540-2286; e-mail: lamagerramova@mail.ru).

Eugene Kratt is leader in a powder metallurgy department of Laboratory of New Technology, Moscow 121596 RF (phone +79166816682, e-mail kratt@rambler@ru)

Pavel Presniakov was with Voronezh State University, Voronezh, 394036 RF (e-mail: p.presniakov@hotmail.com).

separately cast blades and disc produced by mechanical methods and methods of hot isostatic pressing. Heat-resistant nickel alloys used for these parts are different due to differences in operating conditions. High-temperature turbine wheels are operated under high centrifugal loads and relatively low temperatures, varying from the hub to the rim from 400 to 700 °C.

The blades are exposed to centrifugal forces and high gas temperatures (up to 1000-1100 °C). This requires blade cooling by air which comes into internal channels. Thus, the blade is a complicated hollow structure comprising various internal components that may be represented as partitions, pins, matrices, lattices, and etc. Such cooled blades are also provided with openings for air blowing, for example in the form of slots in the trailing edge. It is necessary to assure the least possible thickness of the trailing edge because of requirements to gas-dynamic efficiency. In addition, there are often perforations in the blades to organize the film cooling. Blades examples are shown in Fig. 1.

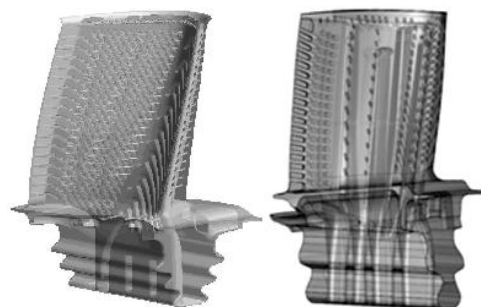

Fig. 1 Examples of cooled blades of high-temperature turbines

Traditional technologies based on precision casting or machining encounter serious constraints in production of such items due to serious difficulties to ensure the complex of requirements of geometric complexity and accuracy of a given level as well as material service and technological characteristics distribution [1], [2]. Furthermore, conventional fir tree connection does not allow by the reason of strength to improve the design in direction of increasing the durability, gas-dynamic efficiency and reducing the wheel weight.

This research presents high-pressure gas turbine wheel with cooled blades made as an integral construction and methods of its production based on powder metallurgy and additive technologies (AT) [3], [4].

## II. TURBINE WHEEL DEVELOPMENT

Developed on the basis of a conventional assembled turbine wheel (prototype), the structure represents a single part which consists of a disk of a nickel alloy connected with separately manufactured cooled blades of another heat-resistant nickel alloy [5].

Upon designing the profile of the blades up to the blade platform corresponds to the prototype. The blade platform, root, and disc part were changed (Fig. 2).

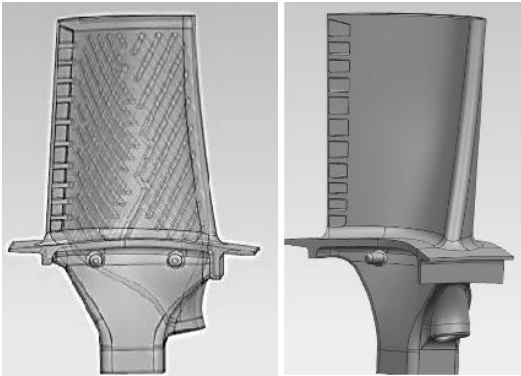

Fig. 2 Developed cooled working blade

Instead of a “fir tree” type connection to the disk, an extended shank is designed. The blade platform has curved borders similar to the root section of the blade. This platform has not too long overhanging parts, which makes the design more rational. The root gradually decreases from the train shelf to the disk section of the rectangular cross-section [6]. The complexity of the one-piece bimetallic wheel development is subject to provision of cooling air to the blades avoiding the area where the disc is connected with blades (Fig. 3). On the assembled (locking) wheel, the cooling air is fed into the blades through the lock connection. The engineered design of the bimetallic mono-wheel assures cooling air supply to the working blades directly in the blade [7]. For this purpose, the blades are fitted with special nozzles.

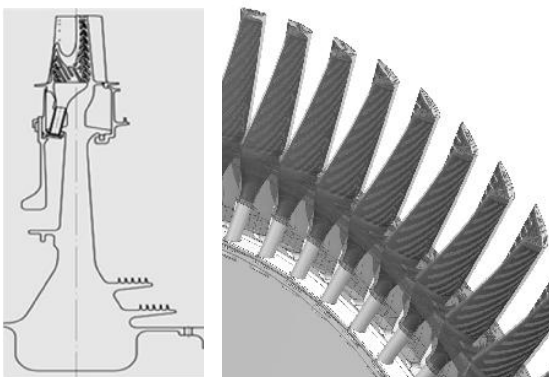

Fig. 3 The developed design of bimetallic mono-wheel

According to the calculations, the strength characteristics of the developed bimetallic wheel are fully compliant with the

resource requirements of correspondent standards. Herewith, the mass of the blisk is 14% less than the original lock design and can be further reduced by the disk section optimization.

Experimental verification is necessary for verification of the design characteristics.

## III. ADDITIVE TECHNOLOGIES (AT) FOR COOLED BLADES PRODUCTION

The blades may be manufactured by conventional casting methods. However, this method is associated with time-consuming and expensive work on design and manufacture of molds. Additionally, molds produced during prototype stage cannot be used for future production.

Each new version requires mold manufacture by mechanical milling, then manufacture of wax models of the outer shell and of the core to form inner channels of the cooled blade, and then production of ceramic molds of the shell and the core. When all ceramic elements of each blade and the entire mold-supplying system are assembled, casting operations are implemented to manufacture the blades.

To accelerate and simplify the process of the blades manufacturing, several options are considered, which are based on the possibilities of AT. 3-D printing can rapidly produce: mold to form the outer element for molding of the cooled blade; mold to form the ceramic rod; burnable (lost-wax) models; ceramic rods as well as the entire metal blades.

### A. Molds Manufacturing

Traditional blade manufacturing procedures can be replaced by additive methods at various stages. Manufacture of molds starts with the semi-finish product casting engineering in accordance with the drawing of the part and technological allowances for machining and with consideration to shrinkage of the model composition and the melted alloy.

Instead of manufacturing by mechanical milling (Fig. 4), molds can be made by additive technology methods.

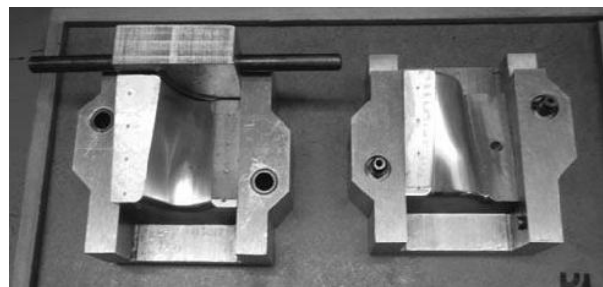
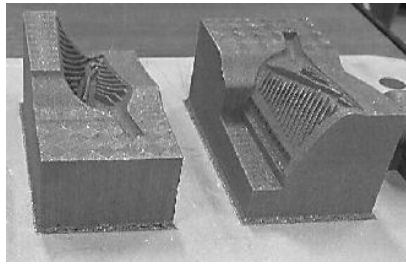
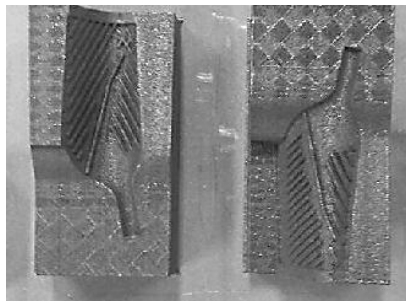

Fig. 4 Mold manufactured by machining method

Fig. 5 shows the molds to produce elements required for the blades casting process: for the subsequent ceramic core formation by the traditional method and for formation of the burnable (melted) model of the blade. Molds are made by the Direct Metal Laser Sintering technology (DMLS) using 3D Systems ProX300 with AlSi10Mg (10-40 microns) powder [8].



(a)



(b)

Fig. 5 Mold shape elements for formation of the burnable blade (a) and core (b)

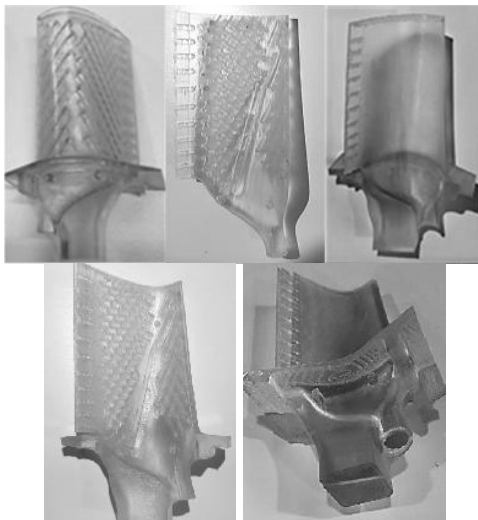

Fig. 6 Elements of the burnable model of the cooled blade

The obtained models can be used in further traditional process of blades manufacturing.

#### *B. Manufacture of the Burnable (wax) Model of the Blade*

Wax models creation stage using molds can be replaced by cultivation of the burnable model of the blade. To obtain the model of the engineered blade, 3D Systems ProX 800 Systems was used, allowing creating parts of liquid polymer by stereolithography (SLA) technology [9].

In order to check the assembly ability, models of the core, the blade and the two parts of the burnable model were made.

Fig. 6 shows the elements of the burnable polymer Accura® 60.

The obtained models can be used to make ceramic molds of the core and outer shell of the blade.

#### *C. Ceramic Core*

The core represents the hollow area of the future blade. It serves as a liner and is later removed from the mold by means of alkali.

Instead of core mold manufacturing, it can be directly produced with aluminum oxide  $Al_2O_3$  using additive SLA technology with incomplete baking at  $1300\text{ }^\circ\text{C}$ . The cores of the designed blade are manufactured using an industrial 3D printer Ceramaker by 3DCERAM (Fig. 7).



Fig. 7 Ceramic core for the blade

#### *D. Metal Blade*

And finally avoiding all of the above described operations it is possible to print cooled blades of nickel alloy powder directly. The only additional stage in this case would be machine post treatment. For this purpose, the above-mentioned printer ProX 300 was used. The material for the blade manufacture is nickel alloy powder ZhS6K with granule-metric composition of 10-50 microns corresponding to the specifications of TU1-595-16-1514-2015 and manufactured by the Russian company All-Russian Institute of Aviation Materials (VIAM) using gas atomization. Fig. 8 shows the manufactured blade.



Fig. 8 The blade manufactured by DMLS technology

The latter option (direct metal printing) is the fastest one. However, unlike cast alloy, the mechanical properties of the parts produced by additive methods from powder materials may differ substantially. Therefore, it is necessary to carry out a range of preliminary studies to determine the mechanical

properties on the samples obtained by this method. The parameters of building process shall be set so that the strength characteristics of the obtained samples meet the requirements to the design and are not lower than the cast sample characteristics.

The parts manufactured using DMLS technology should be subjected to hot isostatic pressing (HIP) to seal the material as well as to heat treatment to relieve residual stresses generated during manufacturing. Machining is also necessary to achieve the required surface finish. But, these operations are also required for the blades obtained by casting. Moreover, manufacturing process shall be stable and repeatable.

#### IV. APPLICATION OF POWDER TECHNOLOGIES FOR MANUFACTURING OF THE TURBINE WHEEL

Recently, experts have been rapidly developing advanced technological processes of structural materials production based on liquid alloy spraying and their solidification with high velocity in the form of pellets or other particles of small size, followed by their compaction in semi-finished products similar in shape and size to the finished part.

With regard to the developed mono-wheel design, the following technological process based on the method of hot isostatic structural elements pressing of powder nickel alloys was designed. It is advisable to manufacture the central part of the disc separately in order to minimize shrinkage during the final forming of the mono-wheel.

At the next step, the manufactured blades are connected with the central part of the disc. Both of these stages are carried out in specially designed capsules that are shaping elements. The capsule for the production of the central part of the structure is filled with nickel alloy powder EP741NP produced by Russian company VILS LLC (fractions -100+63 microns) obtained by a rotating electrode method.

After compacting, the obtained central part of the disk is assembled with the blades in a different capsular mounting providing fixation of the blades in the course of the next stage of bimetallic mono-wheels manufacture with the cooled blades (Fig. 9) [10].

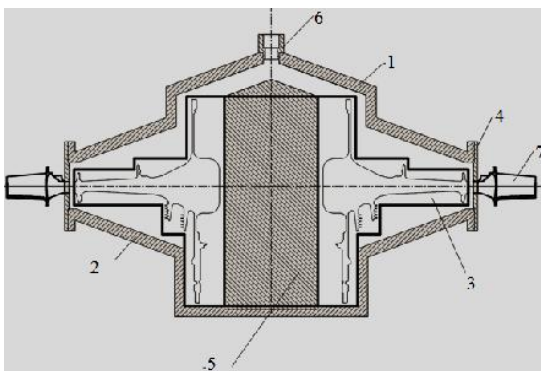

Fig. 9 Construction of the shaping element for mono-wheel manufacturing

This mounting includes curved plates (1 and 2 in Fig. 9),

technologic ring (4) with blades (7). The central part of the disc is placed in the capsule (5). The annular ring gap between the technologic ring with blades and the central part of the disc through the nozzle (6) is filled with powder used for the central part of the disk. The initial powder density in the annular gap was chosen to be 65%, provided by the vibration sealing parameters of the pellets into the capsule.

As a result of gas-isostatic treatment process baking of powder with the central disk portion and blades feet is performed. The final stages of the designed structure manufacturing (Fig. 10) are heat treatment and removal of the capsule.

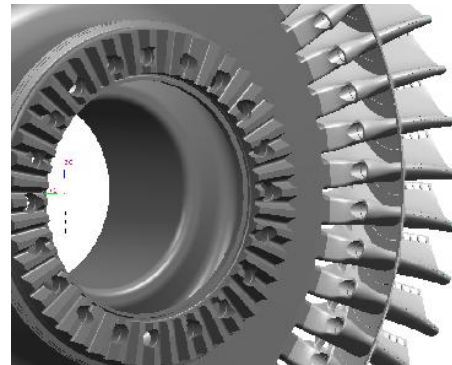

Fig. 10 Bimetallic mono-wheel

#### V. CONCLUSION

As exemplified by the engineered turbine wheel of a high-temperature turbine of advanced gas turbine engine, perspective possibilities of additive methods for manufacturing of cooled blades of complex shape, combined with the methods of powder metallurgy for manufacture of bimetallic mono-wheels from heterogeneous materials have been presented in current research.

#### REFERENCES

- [1] L.A. Magerramova, B.E. Vasilyev, V.S. Kinzburski, "Novel designs of turbine blades for additive manufacturing," in *Proc. TurboExpo2016 Conf., Seoul, 2016, GT2016-56084*.
- [2] L.A. Magerramova, B.E. Vasilyev, "Advanced gas turbine engines blades: biologically-based design and additive technology implementation," *Paper presented at 8th Int. Conf. Beam technologies and laser application, St. Petersburg, 2015, unpublished*.
- [3] L. . Magerramova, P. Kratt, P. Zakharova, V.V. Yacinsky, "The structural and technological design feature of bimetallic blisks for high temperature gas turbine aviation engines," in *Proc. 2nd European EUCASS Conf., Brussels, 2007 CD*.
- [4] L. A. Magerramova, "The project development of HIPed Bimetallic Blisk with Uncooled and Cooled Blades for Engine Gas Turbine of Difference Using," in *Proc. HIP'14 Int. Conf., Stockholm, 2014, id: 140605-1035*.
- [5] L.A. Magerramova, "Achievement of bimetallic blisks integrate dissimilar alloys for promising high temperature aviation gas turbine engines," in *Proc. 28th Congress of the International Council ICAS 2012, Brisbane, 2012, ID No: 224. CD*.
- [6] L.A. Magerramova, P. Kratt "A method of manufacturing an integrated turbine blisks of various metal alloys for gas turbine engine," *Ru patent #2579558, Published on 08.02.2016*.
- [7] L. . Magerramova, P. Kratt, V.V. Yacinsky, "A method of manufacturing integral blisks with cooled blades, integrated blisk and cooled blade for gas turbine engine," *Ru patent #2478796, Published on*

10.04.2013.

- [8] Jason C. Fox, Shawn P. Moylan, Brandon M. Lane, "Effect of Process Parameters on the Surface Roughness of Overhanging Structures in Laser Powder Bed Fusion Additive Manufacturing" *Procedia CIRP, Volume 45, 2016, Pages 131-134.*
- [9] S.O. Onuh, K.K.B. Hon, "Optimising build parameters for improved surface finish in stereolithography", *International Journal of Machine Tools and Manufacture, Volume 38, Issue 4, March 1998, Pages 329-342*
- [10] L.A. Magerramova, S.S. Baculin, "The method of positioning the blades in the manufacture of integral blisks turbine of a gas turbine engine," *Ru patent #2595331, Published on 03.08.2016*

**Liubov A. Magerramova** graduated from Moscow Aviation Institute (MAI) as a specialist-engineer-mechanic. After post-graduate course in MAI she was awarded the degree of Doctor of Science and the position of "Senior Researcher". L.A.Magerramova works as Chief of Group in Department of Strength of Central Institute of Aviation Motors (CIAM, 2, Avimotornay st., 111250, Moscow, Russia). In 2012 she was awarded the following academic degree PhD. The subject of her dissertation research is the methods of creation of bimetallic blisks for high temperature gas turbine engines of difference using.

She is a specialist in the field of compressor vane strength, cooled and uncooled blades, including single-crystal blades. She designed and formed data base on structural strength of the materials used in engine building. At present she is a head of the lead in the field of calculations and experimental studies, design and development of undetectable constructions, combined of heterogeneous materials for parts and units of next-generation engines. She is currently engaged in the development of constructive - technological decisions of creation of details promising gas-turbine engines with the use of methods optimization and additive manufacturing.

PhD, scientist research Liubov A. Magerramova is the author of patents, publications, participant of international conferences HIP, EUCASS, ICAS, and other.