

Reliability Analysis for Cyclic Fatigue Life Prediction in Railroad Bolt Hole

Hasan Keshavarzian, Tayebeh Nesari

Abstract—Bolted rail joint is one of the most vulnerable areas in railway track. A comprehensive approach was developed for studying the reliability of fatigue crack initiation of railroad bolt hole under random axle loads and random material properties. The operation condition was also considered as stochastic variables. In order to obtain the comprehensive probability model of fatigue crack initiation life prediction in railroad bolt hole, we used FEM, response surface method (RSM), and reliability analysis. Combined energy-density based and critical plane based fatigue concept is used for the fatigue crack prediction. The dynamic loads were calculated according to the axle load, speed, and track properties. The results show that axle load is most sensitive parameter compared to Poisson's ratio in fatigue crack initiation life. Also, the reliability index decreases slowly due to high cycle fatigue regime in this area.

Keywords—Rail-wheel tribology, rolling contact mechanic, finite element modeling, reliability analysis.

I. INTRODUCTION

IN recent years, railway transportation has developed rapidly to satisfy the need of national economic development. Due to high axle load, speed, and traffic volume, the cost of maintenance caused by wear and fatigue, has increased [1]. Main factors of crack initiation in railway industry include: (a) operation condition (b) quality of rail production. Zerbst et al. [2], by gathering information from various sources in Great Britain, state that the failures of wheels and axles have decreased 20 times over the last century, while failures of rails per train kilometer have increased more than two times. The conjunction of two ends of rails is one of the sensitive points in track. Common damages in rail joint area include: squashing, crack in bolt hole, saddle back wear, and spalling [3]. Fig. 1 shows the damage of crack in bolt hole.

Mayville and Hilton [4] carried out analytical and experimental investigation to establish the cause of peculiar ridge features observed on the fracture surface of rail-end bolt hole fatigue crack. Their results indicate that the ridges were caused by the thermal expansion of the rail during each day. Also, they could reproduce the ridge features by a novel laboratory experiment on a four-hole compact tension specimen.

Hasan Keshavarzian is with the Mechanical Engineering Department, Iran University of Science and Technology, Tehran, Iran (corresponding author, phone: +98-936-301-6410; fax: +98-21-55128295; e-mail: ha_keshavarzian@mecheng.iust.ac.ir).

Tayebeh Nesari was with the Railway Engineering Department, Iran University of Science and Technology, Tehran, Iran. She is now with Railway of Iran (RAI). (e-mail: nesari_t@rai.ir).



Fig. 1 Crack in rail bolt hole

Mayville and Stringfellow [5] used a finite element analysis (FEA) to study the effects of joint bar looseness, rail height mismatch, and train speed on the crack driving force for a crack initiation from a bolt hole in the web of a rail. The results show that the crack driving force increases about 25% as the joint loosens. Kataoka et al. [6] conducted static loading experiments in a laboratory; field tests to measure the stresses around the fishplate hole, static stress analysis of jointed rail, and bending fatigue tests of rails with bolt hole. Based on the test results, they developed a method to evaluate the fatigue life of jointed rails. Cheng et al. [7] investigated the effect of low and high loading rates on the fatigue behavior of rail steel. Arnold and Joel [8] presented an accurate analysis for the bonded insulated joint which has a good conformity with the obtained test results on actual bonded joints. Jin et al. [3] simulated the wheel/rail contact-impact behavior at rail joint region by the finite element code ANSYS/LS-DYNA. They found that the axle load has more great effect on the stresses and strains in railhead than train speed, during impact process. Wen et al. [9] studied dynamic elastic-plastic stress when a wheel passes a rail joint with height difference between the two sides of a gap. In this situation, the results indicate that the train speed has larger effect on the contact force, stress and strain than the axle load. Ding and Dhanasekar [10] established a finite element model which examined the effect of looseness of the bolts on the in-plane deformation characteristics of the joint. Talamini et al. [11] studied the influence of track condition on the fatigue life of the joint bars. In this research, the wheel is modeled as a rigid cylindrical surface which is not correct assumption. Himebaugh et al. [12] investigated the effects of the location of the wheel, the size of sleeper, length and thickness of the joint bars on vertical displacement, and shear and normal stresses in the epoxy layer. Their results show that when the standard sleepers were replaced by the larger sleepers, the maximum deflection and the maximum stresses tended to decrease slightly. Increasing the joint bars' length tended to

decrease the maximum shear stress and to increase the normal stress. Increasing the joint bars' thickness tended to increase the maximum stress significantly.

In practical, the amplitude and frequency of loading and material properties are stochastic variables. There are few published studies on probability and reliability analysis in rolling contact fatigue of rail. Jianxi et al. [13] provided a comprehensive approach for studying the probability of fatigue crack initiation under random force and random material properties. Three-dimensional FEM was created to predict rail surface and subsurface stresses under different amplitudes of wheel/rail forces. They confirmed that the prediction results of the FEM model are in good consistence with the observations in field. Josefson and Ringsberg [14] investigated the risk for fatigue crack initiation in the railhead and web in the weld zone of a rail. They assumed that the welding residual stress shape and magnitude, the magnitude of contact force, and the material properties used in fatigue life prediction are varied. The fatigue crack initiation was assessed by using the multiaxial fatigue criterion proposed by Dang Van, and the fatigue crack propagation was carried out with the Paris' law. Mohammadzadeh et al. [15] investigated fatigue crack initiation prediction of railhead in bolted rail joint by using FEM, response surface method (RSM), and reliability analysis. They found that due to the low cycle fatigue regime in this area, the reliability index decreased rapidly. Liu and Mahadevan [16] proposed a general methodology for fatigue reliability of wheels. They developed multiaxial fatigue model which include both fatigue crack initiation and fatigue crack propagation life.

Since there are no published studies about reliability analysis of fatigue crack initiation bolt hole at the joint region, this problem was investigated comprehensively by using FEM, RSM, and reliability analysis in this research.

II. PROBLEM STATEMENT

The nature of applied wheel/rail contact force on tracks is dynamic. The magnitude of this dynamic load depends on speed, the properties and qualities of train and track. The main effective factors of vertical force increase between rail and wheel include: isolated irregularities in the running surface (bolted joints and welds), periodic irregularities (corrugation on the rail surface and sleeper spacing), defects in the vehicle (wheel flat and wheel eccentricity), and roughness variations of rail surface area [17]. So, field and laboratory studies have been conducted in order to obtain time history plot of dynamic force on the rail when wheel is passing the rail joint area [11], [17]. Jenkins et al. [17] have investigated various effective parameters on level of dynamic forces at bolted rail joint over three year's field tests. They found that this crossing procedure has two peak forces, as shown in Fig. 2. The first peak force (P1) has high frequency which causes battering rail end surface. The second peak force (P2) occurs in the vicinity of first sleeper causing the track deflection [17]. The value of P1 is always larger than P2, but the duration of P2 is about four to ten times longer compared to P1 [11]. According to the results of experiments (Fig. 2 (b)), the combination of P1 and

P2 governs the stress and strain ranges in the first bolt hole. Equations (1) and (2) were proposed to estimate dynamic contact forces on suspended rail joints as follow:

$$P_1 = P_0 + 2\alpha V \sqrt{\frac{K_H m_e}{1 + \frac{m_e}{m_u}}} \quad (1)$$

$$P_2 = P_0 + 2\alpha V \left(\frac{m_u}{m_u + m_t} \right)^{1/2} \left(1 - \frac{C_t \pi}{4K_t(m_u + m_t)} \right) \sqrt{K_t m_u} \quad (2)$$

where P0 is the static wheel load (N), mu is the vehicle unsprung mass (kg), V is the speed (m/s), 2α is the total angle (rad) (this angle consists of two components; one due to permanent deformation of the rail end and the other one due to deflection of the joint under load), mt, Kt, Ct are the equivalent track system parameters (kg, N/m, Ns/m), and KH is the linearized Hertzain contact stiffness (N/m). Also, the type of rolling contact force is non-proportional loading. Comprehensive method is proposed for examination of all affecting factors on fatigue crack initiation in rail bolt hole. In this problem, most of the affecting factors on fatigue crack initiation are considered as random variables. The scenario of this method is explained as follows:

The levels of stresses and strains are generated randomly in the bolted rail joints due to passing trains on this area with different number of cars, speed and axle load, and also random material properties of rail. In this study, dynamic forces are computed by (1) and (2). In the next step, the fatigue crack initiation life is estimated for each passing wheel by using the stress and strain tensor which was obtained from FEA and selection of an appropriate fatigue crack initiation criteria. Cumulative damage parameter is computed for each passing train by the linear Miner's law. Finally, reliability analysis is conducted by proposing an appropriate limit state function.

III. FATIGUE MODELING OF RAILROAD BOLT HOLE

A. Numerical Simulation of Railroad Bolt Hole Stress-Strain

The numerical simulation was established based on information of one block of Iran railway network. The standard rails of UIC60 and profile S1002 wheel are used in this block. The length of rails each side of joint is equal to 500 mm, and the lateral gradient is 1/20. The beam element with geometric characteristics of UIC60 rail is coupled to the neutral axis of rail according to Fig. 3 (a) in order to evaluate the rail deflection exactly. The gap between two ends of rails is equal to 4 mm based on climate. The coefficient of friction between wheel and rail is equal to 0.3, and it is selected as 0.4 between rails and joint bars, joint bars and bolts and bolts and rails [9]. Foundation stiffness and damping values are 3.09×10^4 kN/m and 1.44×10^4 Ns/m, respectively. Spring spacing is equal to 600 mm based on sleeper spacing. The bolt preload is calculated by experimental relation as follows:

$$P_b = \frac{T}{KD} \quad (3)$$

where P_b is the bolt preload, $T=500$ N-m is the bolt torque moment, $D=27$ mm is the bolt diameter (M27), and $K = 0.2$ is the coefficient of bolt torque moment [9]. Fig. 3c shows Von Mises stress contour. Material responses of wheel, joint bar, and bolt are elastic. But, material model of rail is considered

as linear kinematic hardening for FEA. In this study, number of trains per day, number of cars in a train, axle load, and speed are also considered as stochastic variables. The material properties of components and train are presented in Table I [11], [18].

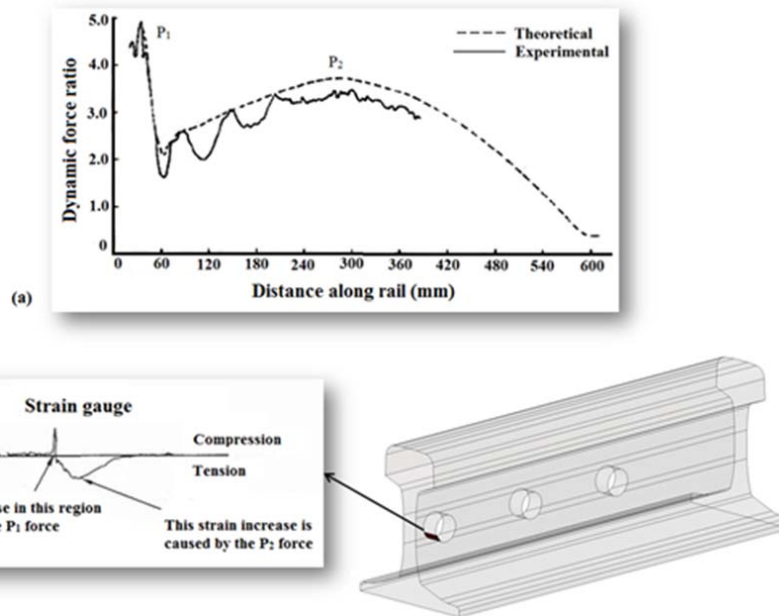

Fig. 2 (a) Dynamic force ratios during a passing wheel, (b) bolt hole strain

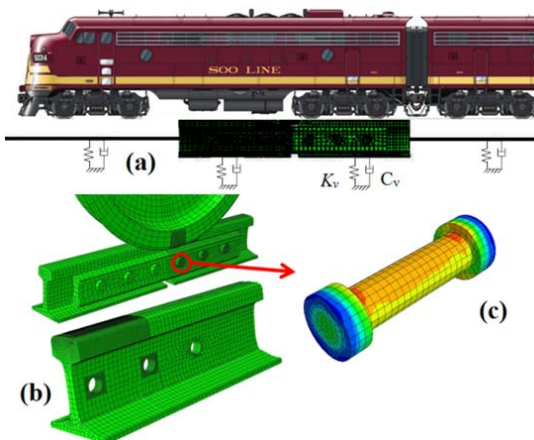

Fig. 3 (a) Bolted rail joint, (b) Meshed model of bolted rail joint, (c) Von Mises stress contour due to apply pre-load on bolt.

B. The Prediction Model of Fatigue Crack Initiation

Various models were proposed for rolling contact fatigue (RCF) research, which is limited specifically. Because of non-proportional loading and high level of stresses in contact area, the fatigue life prediction of stress based and strain based approaches are not appropriate. Although energy based approach can be used for non-proportional loading, but these types of criteria could not determine a specific plane for crack initiation or direction of crack propagation as energy is a

scalar quantity [18]. Critical plane based approach is a good method for explaining the observed behavior of initiation and propagation of fatigue cracks on specific planes. Ratcheting based fatigue life prediction is proposed for ratcheting material response. Therefore, based on this model, the fatigue life prediction of cracks initiation is infinite for plastic shakedown material response [18]. So, in order to predict the rolling contact fatigue life, combined energy-density based and critical plane based fatigue models are more appropriate. In these models, energy-density is computed as fatigue parameter on every material plane for every increment cyclic loading. The material plane subjected to the largest value of the fatigue parameter during cyclic loading is defined as the crack plane, and then, it is evaluated using critical plane approach. Hence, this approach has advantages of two approaches. According to the previous studies of RCF, the Jiang and Sehitoglu model was chosen as the most appropriate model for evaluation of RCF [13]. Since the failure mode of RCF crack initiation is shear, so fatigue initiation life was computed from (4).

$$\begin{aligned}
 FP_{\max} &= \left(\left(\tau^{\max} + |\sigma^{\max}| \right) \frac{\Delta\gamma}{4} + J \Delta\sigma \Delta\varepsilon \right)_{\max} \\
 &= \frac{(\tau'_f)^2}{G} (2N_f)^{2b} + \tau'_f \gamma'_f (2N_f)^{b+c}
 \end{aligned}
 \tag{4}$$

where $\Delta\gamma$ is the shear strain range on the critical plane, $\Delta\varepsilon$ is

the strain range normal to the critical plane, τ^{\max} is the maximum shear stress on the critical plane, $\Delta\sigma$ is the stress range normal to the critical plane. The constant J should be obtained from experiments. G is the shear module. In order to find the critical plane bolt hole which is subjected to cyclic loading, critical point should be determined at the beginning. In this point, Von Mises stress has its maximum value during cyclic loading. The cumulative damage method is used for finding the critical plane [19].

TABLE I

.MATERIAL PROPERTIES OF COMPONENTS AND TRAIN'S INFORMATION				
Component	Parameter	Distribution	Mean value	Standard deviation
Wheel	elastic modulus (GPa)	Constant	210	-
Joint bar	Poisson's ratio	Constant	0.3	-
Bolt	density (kg/m ³)	Constant	7800	-
Rail	Elastic modulus (GPa)	Normal	209	10.45
	Yield stress (MPa)	Normal	406	20.3
	Poisson's ratio	Constant	0.3	-
	Fatigue strength index, b	Normal	0.089	0.0045
	Fatigue strength coefficient τ'_f (MPa)	Normal	468	23.4
	Fatigue ductility index, c	Normal	-	0.028
	Fatigue ductility coefficient γ'_f	Normal	15.45	0.7725
Train	J coefficient	Constant	0.2	-
	Number of trains per day	Lognormal	10	1
	Number of wagons	Lognormal	38	2
	Axle load (ton)	lognormal	25.5	3.75
	Speed (km/h)	Normal	50.74	9.109

IV. FATIGUE RELIABILITY ANALYSIS OF RAILROAD BOLT HOLE

A. Reliability Analysis

“Reliability is the probability that a system will perform its function over a specified period of time and under specified service conditions” [20]. For this analysis, we should define a limit state function. This function is equal to the difference between strength and the load of structures under operation conditions. The limit state function $g()$ and probability of failure Pf can be computed as:

$$g(X) = S(X) - L(X) \tag{5}$$

$$P_f = P[g(0) < 0] = \int_{-\infty}^0 f_g(g) dg \tag{6}$$

where S is the strength term, and L is the loading term. In this study, the critical value of Palmgren-Miner linear damage rule (Δ) is defined as the strength term. The nature of this parameter is also random, and mean value and coefficient of variation are 0.95 and 0.26, respectively. The loading term is obtained by product of number of passing train during operation period (n) and damage parameter caused by one passing train (D_{train}). These two variables were considered

stochastic and independent. So, (9) is considered as limit state function. Due to complexity and nonlinearity in contact problem, Monte Carlo method was used for reliability analysis. The main advantages of this method are stochastic simulations, high speed of convergence and effective method for nonlinear problems. The convergence of statistical results would be guaranteed when the trial of simulations was repeated enough. If the total number of negative value of limit state is displayed with Nf then probability of failure will be as:

$$g(X) = \Delta - nD_{train} \tag{7}$$

$$P_f = \frac{N_f}{N} \tag{8}$$

B. Response Surface Method (RSM)

Due to large uncertainties involved in fatigue analysis and field observations, a stochastic fatigue life prediction method should consider various uncertainties in material properties, contact load, and speed. So, too many FEM simulations should be done for Monte Carlo method. Since, total time for each FEA was about 22954 seconds, FEA of all samples is too time consuming and expensive. Hence, RSM was used to solve this problem. The RSM explores the relationship between several explanatory variables and one or more response variables by using a few sample points. This method locates the sample points in the space of random input variables such that an appropriate regression function can be found most efficiently. Based on the parametric studies of the fatigue crack initiation analysis, several important factors are chosen as input variables. The output variables are all components of stresses and strains on critical plane. Full quadratic design was used to design the numerical experiments by applying central composite design. The approximation function is described as:

$$\hat{X} = \alpha + [U_1 \dots U_n] \begin{bmatrix} \beta_1 \\ \cdot \\ \cdot \\ \beta_n \end{bmatrix} + [U_1 \dots U_n] \begin{bmatrix} \gamma_{11} & \cdot & \cdot & \cdot & \gamma_{1n} \\ \cdot & \cdot & \cdot & \cdot & \cdot \\ \cdot & \cdot & \cdot & \cdot & \cdot \\ \cdot & \cdot & \cdot & \cdot & \cdot \\ \gamma_{n1} & \cdot & \cdot & \cdot & \gamma_{nn} \end{bmatrix} \begin{bmatrix} U_1 \\ \cdot \\ \cdot \\ \cdot \\ U_n \end{bmatrix} \tag{9}$$

where U_i are the random variables, α is the coefficient of constant term, β_i is the coefficients of linear terms, and γ_{ij} is coefficients of quadratic terms. The process of RSM analysis includes: (a) design of experiments (b) calculation of P1 and P2 (c) conduct FEM and obtain tensor of stresses and strains for each experiment (d) calculation of fatigue parameters and determine the direction of critical plane (e) explore a relation

between input variables and output results.

According to Jenkins' experiments (Fig. 2 (b)) [17], the combination of P1 and P2 governs the stress and strain ranges in the first bolt hole and also the fatigue crack initiation. Response surface analysis is based on central composite and full quadratic type. Based on this method, 31 experiments were recommended for each dynamic load, P1 and P2. The lower, middle, and upper values for the four variables are listed in Table II. The output variables are stress and strain components on critical plane.

The point that has maximum Von Mises stress is considered as critical point. Then, the direction of critical plane is determined by tensor of stress and strain and fatigue parameter in (4). The contact areas between wheel and rail and around of

bolt holes are meshed very fine in order to obtain more accurate results (Fig. 3 (b)). Fig. 4 shows contour of Von Mises for the 6th experiment. Next, according to the results of FEM and MATLAB's code, the coefficients of quadratic regression are found. Four functions for each of four output variables are fit based on four input variables.

TABLE II
DESIGN VALUES FOR THE RANDOM VARIABLES

Random variable (unit)	Lower	Middle	Upper
Axle load (ton)	14.25	25.5	36.75
Speed (km/h)	23.5	50.74	78
Elastic module (GPa)	177.65	209	240.35
Yield stress (MPa)	345.1	406	466.9

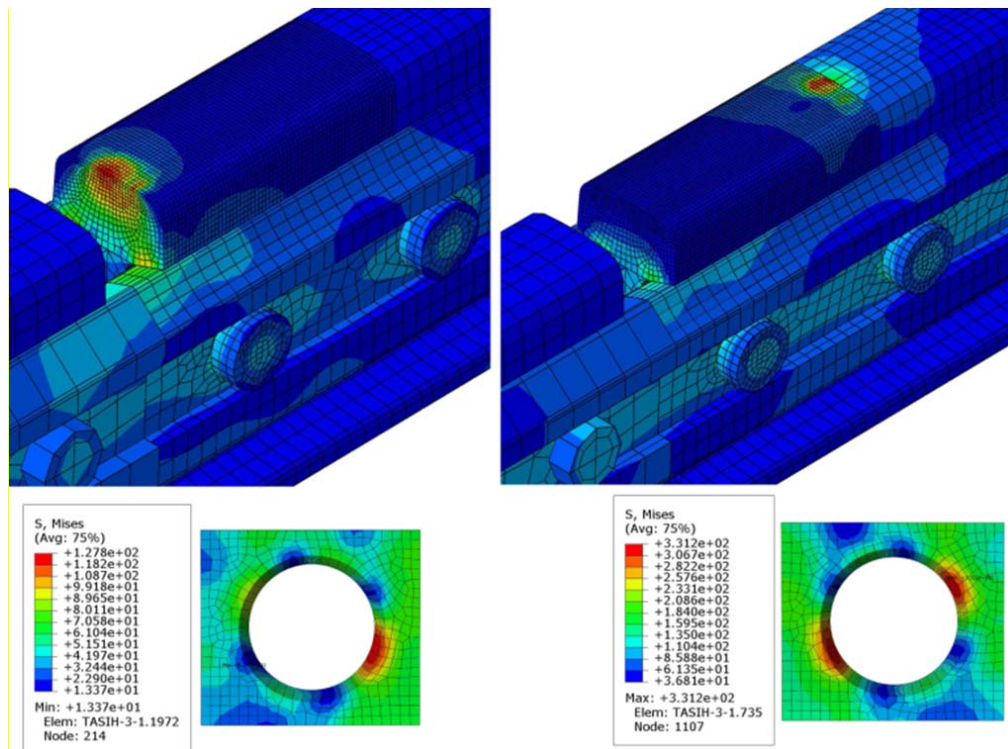

Fig. 4 Von Mises stress contour due to apply P1 and P2 forces, experiment No. 6

V. RESULTS

In this paper, the stochastic variables include: axle load, speed, number of train wagons, volume of traffic per a month, and material properties of rail. First, 100000 trains and tracks are generated based on statistical information of the block. The total number of wagons and axle load related to these trains are equal to 3799730 and 15198920, respectively. The values of stresses and strains in critical plane are computed by generated samples of input stochastic variables. Next, the fatigue crack initiation life of each wheel loading is calculated. Finally, by the Palmgren-Miner linear rule, the value of cumulative damage parameter is calculated for crossing of one train with random number of cars.

After Monte Carlo simulation, the convergence of damage

parameter should be verified. Fig. 5 shows the convergence graph of damage parameter for one train passing. The mean value and the variance for bolt hole damage are 1.434×10^{-6} and 1.07×10^{-12} , respectively. Also, the cumulative probability of this parameter is presented in Fig. 6. As seen, histogram of this parameter has good conformity with log-normal distribution. Fatigue regime is high cycle fatigue (HCF).

When the data of bolt hole damage index were calculated completely, 100000 samples of number of trains per day and critical value of Miner linear damage rule were generated based on their distributions. Now, limit state function which was mentioned in (9) is analyzed. The orientation of unit normal vector n of critical plane is varied as: $53^\circ < \phi < 63^\circ$ and $52^\circ < \theta < 66^\circ$. Fig. 7 shows probability of failure versus

operation time (month). The probability of failure for 1000th months is 0.0952. Another well-known parameter, safety index or reliability index, is used for the reliability evaluation. The reliability index indicates the distance of the mean margin of safety (mean value of limit state = μ_g) from limit state surface ($g(x)=0$). The value of this parameter decreases from 3.3 to 1.35.

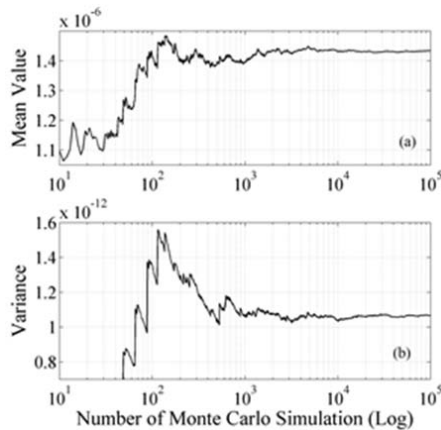

Fig. 5 Convergence graphs of Monte Carlo simulations for (a) mean value (b) variance

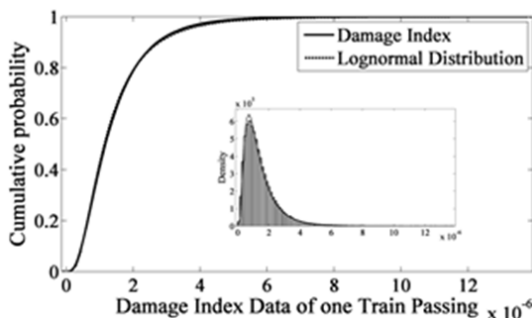

Fig. 6 Cumulative probability of damage index for one passing train

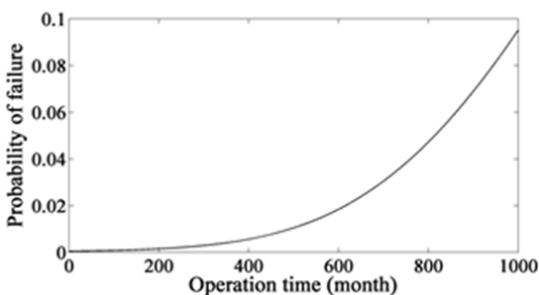

Fig. 7 Probability of failure versus operation time

VI. CONCLUSION

In this paper, we could develop a comprehensive and probability method for examination of fatigue crack initiation in railroad bolt hole by using finite element method, RSM and reliability analysis. According to sensitive analysis and Monte Carlo simulation by Latin hypercube sampling, the axle load

and yield stress are more effective parameters than Poisson's ratio on output results. Also, we could achieve the appropriate relationship between FEM results and stresses and strains in critical plane by using a few sample points. Direct Monte Carlo method was used for reliability analysis. Angle changes of critical plane are between $53^\circ < \phi < 63^\circ$ and $52^\circ < \theta < 66^\circ$. According to the FEM results, the type of fatigue regime of bolt hole is high cycle fatigue. So, for this reason, the reliability index of bolt hole decreases from 3.3 to 1.35 during time of operation. The histogram of damage index of bolt hole is in accordance with lognormal distribution.

REFERENCES

- [1] D. F. Cannon, K.-O. Edel, S. L. Grassie, K. Sawley, Rail defects: an overview. *Fatigue Fract. Engng Mater Struct* 26, 2003, pp. 865-887.
- [2] U. Zerbst, R. Lunden, K.-O. Edel, R. A. Smith, Introduction to the damage tolerance behavior of railway rails – a review. *J. Eng Fract Mech* 76, 2009, pp. 2563-2601.
- [3] Zefeng Wen, Xuesong Jin, Weihua Zhang, Contact-impact stress analysis of rail joint using the dynamic finite element method. *J. Wear* 358, 2005, pp. 1301-1309.
- [4] Ronald A. Mayville, Peter D. Hilton, Fracture mechanics analysis of rail-end bolt hole crack. *Theoret appl. Fract. Mech.* 1, 1984, pp. 51-60.
- [5] R. A. Mayville, R. G. Stringfellow. Numerical analysis of a railroad bolt hole fracture mechanics. *Theoret appl. Fract. Mech.* 24, 1995, pp. 1-12.
- [6] H. Kataoka, N. Abe, O. Wakatsuki. Evaluation of service life of jointed rails. *QR of RTRI* 43, 2002, pp. 101-106.
- [7] Y. Cheng, D. Chen, F. Nogata. Fatigue behavior of rail steel under low and high loading rates. *Fatigue Fract. Eng. Master. Sci* 17, 1994, pp. 113-118.
- [8] D.K. Arnold, E.C. Joel. Analysis and test of bonded insulated rail joints subjected to vertical wheel load. *Int. J. Mech. Sci* 41, 1991, pp. 1253-1272.
- [9] Wu Cai, Zefeng Wen, Xuesong Jin, Wanming Zhai. Dynamic stress analysis of rail joint with height difference defect using finite element method. *J. Eng Failure Analysis* 14, 2007 pp. 1488-1499.
- [10] K. Ding, M. Danasekar. Flexural Behavior of Bonded-Bolted Butt Joints Due to Bolt Looseness. *J. Advances. Eng. Software* 38, 2007, pp. 598-606.
- [11] Brandon Talamini, David Y. Jeong, Jeff Gordon. Estimation of Fatigue Life of Railroad Joint Bars. ASME/IEEE joint rail conference & internal combustion engine, Colorado, USA. March, 2007, pp. 13-16.
- [12] Anne K. Himebaugh, Raymond H. Plaut, David A. Dillard. Finite Element Analysis of Bonded Insulated Rail Joints. *Int. J. Adhesion & Adhesives* 28, 2008, pp. 142-150.
- [13] W. Jianxi, X. Yude, L. Songliang, W. Liying. Probabilistic Prediction Model for Initiation of RCF Cracks in Heavy-Haul Railway. *Int. J. Fatigue* 33, 2011, pp. 212-216.
- [14] B. L. Josefson, J.W. Ringsberg. Assessment of Uncertainties in Life Prediction of Fatigue Initiation and Propagation In Welded Rails. *Int. J. Fatigue* 31, 2009, pp. 1413-1421.
- [15] S. Mohammadzadeh, M. Sharavi, H. Keshavarzian. Reliability analysis of fatigue crack initiation of railhead in boltea rail joint. *Eng. Failure Analysis*, 29, 2013, pp. 132-148.
- [16] Yongming Liu, Liming Liu, Brant Stratman, Sankaran Mahadevan. Multiaxial Fatigue Reliability Analysis of Railroad Wheels. *J. Reliability Eng. & Sys. Safety* 93, 2008, pp. 456-467.
- [17] H.H Jenkins, J.E Stephenson, G.A Clayton, G.W Morland, D Lyon. The Effect of Track and Vehicle Parameters in Wheel/Rail Vertical Dynamic Forces. *Railway Eng. J*, 2, 1974, pp. 2-16.
- [18] W. Ringsberg, Jonas. Life Prediction of Rolling Contact Fatigue Crack Initiation. *Int. J. Fatigue* 23, 2001, 575-589.
- [19] J. Das, S.M. Sivakumar. An Evaluation of Multiaxial Fatigue Life Assessment Methods for Engineering Component. *Int. J. Pressure Vessel & Piping* 76, 1999, pp. 741-746.
- [20] S.K. Choi, R.V. Grandhi, R.A. Canfield. Reliability-Based Structural Design. Springer-Verlag London, 2007.