

Research and Design on a Portable Intravehicular Ultrasonic Leak Detector for Manned Spacecraft

Yan Rongxin, Sun Wei, Li Weidan

Abstract—Based on the acoustics cascade sound theory, the mechanism of air leak sound producing, transmitting and signal detecting has been analyzed. A formula of the sound power, leak size and air pressure in the spacecraft has been built, and the relationship between leak sound pressure and receiving direction and distance has been studied. The center frequency in millimeter diameter leak is more than 20 kHz. The situation of air leaking from spacecraft to space has been simulated and an experiment of different leak size and testing distance and direction has been done. The sound pressure is in direct proportion to the cosine of the angle of leak to sensor. The portable ultrasonic leak detector has been developed, whose minimal leak rate is 10^{-1} Pa·m³/s, the testing radius is longer than 20 mm, the mass is less than 1.0 kg, and the electric power is less than 2.2 W.

Keywords—Leak detection, manned spacecraft, ultrasonic, sound transmitting.

I. INTRODUCTION

DUE to the space debris and micro meteor impact, the seal cabin of the manned spacecraft on orbit for long time may have some perforations leading to the leak accident. Hence, it is necessary that leak detection and location technology is researched to find leak position for repairing the structural damage. Development of a leak location detector is very important for on-orbit maintenance, which is expediently used in the seal cabin of manned spacecraft by astronauts.

At present, there are some on-orbit leak detection method such as the high sensitivity direction vacuum gauge detection [1], the array-based acoustic leak location [2], the two-sensor ultrasonic spacecraft leak detection [3], the structure-borne noise leak detection [4], the spherically focused capacitive-film air-coupled transducer [5], the ultrasonic array sensor structure leak monitoring [6], and so on. And then, direction vacuum gauge can detect very small leaks and have high sensitivity, but it is used out of the cabin, which needs complex machine or astronauts go to the cabin outside to operate. The structure leak monitoring in-site technology based on array sensor needs many array sensors laid on the spacecraft structure, and this technology is studying in the laboratory. During the research of the portable intravehicular ultrasonic leak detection method and apparatus [7], the physical mechanisms of the leak acoustic signal production, transmitting, and characters are necessarily studied. Hence, the mathematical module is established in this

Yan Rongxin and Li Weidan are with the Beijing Institute of Spacecraft Environment Engineering, Beijing, China (phone: 86-10-68747418, fax: 86-10-68746751, e-mail: pigsheepdog@126.com, liweidanmail@163.com).

Sun Wei is with the Beijing Institute of Spacecraft Environment Engineering, Beijing, China (phone: 86-10-68746253, fax: 86-10-68746751, e-mail: sunwei84@163.com).

thesis. By experiment, results are validated and lead to develop the leak detector.

II. THEORY ANALYSIS

A. The Signal Production from Leak

During the cabin leaking, the air flows out along the leak from cabin to the vacuum under gas pressure. While the gas passing through the tiny aperture, in the case of turbulence, the gas flow velocity is very high, and a number of vortices form turbulence. The interaction of vortex makes the volume elements push each other by the equal and opposite force, causing the production quadrupole jet. According to Lighthill's acoustic analysis [8], the relation of sound power P_T with the diameter d and the thickness l is defined as:

$$P_T \propto \frac{\rho_0 (ud/l)^8 l}{c_0^5} \left(\frac{\rho_s}{\rho_0} \right)^2 \quad (1)$$

where ρ_0 is the atmospheric density in cabin, u is the gas jet velocity at the nozzle, c_0 is the acoustic propagation velocity in the cabin atmosphere, and ρ_s is the standard atmospheric density.

For a closed manned spacecraft cabin, the cabin gas pressure will change due to leaks, so we can acquire the pressure equation by leak rate and cabin pressure P_t :

$$P_t = (P_0 - P_{out}) e^{\left(-\frac{C}{V} t \right)} + P_{out} \quad (2)$$

Here, C is known as the leak gas flow conductance, V is the cabin volume, P_0 is the initial cabin pressure, P_{out} is the vacuum pressure outside of cabin.

Usually, manned spacecraft cabin volume is 10~100m³, the probably leak diameter appears to be between 0.1 mm and 1 mm, the gas flow conductance is small. Equation (2) tells us: for the 0.1 mm leak, 10 m³ cabin, the time of pressure decline 1 kPa needs 10.5h because of air leak. So, in the dimension of minute time of leak testing, the pressure P_t change is very small. The outlet pressure P_{out} is in vacuum, the gas flow velocity u :

$$u = \sqrt{\frac{2\gamma}{\gamma-1} \frac{P_t}{\rho_0} \left[1 - \left(\frac{P_{out}}{P_t} \right)^{\frac{\gamma-1}{\gamma}} \right]} \quad (3)$$

In (3), u is known as the flow velocity of gas through the leak. $\gamma = C_p/C_v$, C_p is the cabin gas thermal capacity at constant pressure, C_v is the thermal capacity at constant volume in cabin, substituting (3) into (1), we have:

$$P_T \propto \frac{\left\{ \frac{2\gamma P_t}{\gamma-1 \rho_0} \left[1 - \left(\frac{P_{out}}{P_t} \right)^{\frac{\gamma-1}{\gamma}} \right] \right\}^4 d^8 \rho_s^2}{\rho_0 c_0^5 l^7} \quad (4)$$

For the leak in large cabin, in minutes, p_t/ρ_0 , P_{out}/P_t and l changes are small. The formula in (4) shows that the eject gas sound power from the leak has direct relation to the leak diameter and length. If the leak length is constant, the leak diameter is larger, the sound power is larger. So, the sound power could be measured, the leak diameter could be ensured.

B. Leak Sound Signal Propagation

The sound signal produced in leak should be transmitted to the sound sensor so that it could be tested. Suppose the jet sound power P_T as point source. In that way, the point source could be assumed as a monopole source, shown in Fig. 1, which is the acoustic wave equation:

$$\frac{\partial^2(rp)}{c_0^2 \partial t^2} = \frac{\partial^2(rp)}{\partial r^2} \quad (5)$$

In the formula, r is the distance of receiving point to sound producing point, and P is the sound pressure at the receiving point. Its sound field solution is

$$p(r,t) = p_A e^{i(\omega t - kr + \theta)} \quad (6)$$

In the formula, $P_A = |A|/r$ is the sound pressure, θ is the signal phase, ω is the phasic angle frequency, k is the coefficient of sound propagation. At the leak sound transmits to the receiving point, the sound strength is:

$$I_r \propto \frac{1}{2r^2} P_T \quad (7)$$

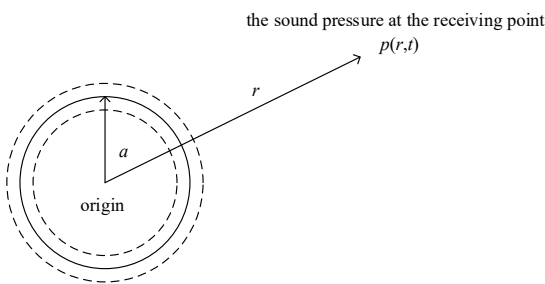

Fig. 1 Sound source transmitting in air

If the angle between the receiving surface and normal of leak is α , using (4), the receiving sound pressure P_{rs} is:

$$P_{rs} \propto \frac{1}{2r} \sqrt{P_T} \cdot \cos \alpha = \frac{\cos \alpha}{2r} \times \left\{ \frac{\left\{ \frac{2\gamma P_t}{\gamma-1 \rho_0} \left[1 - \left(\frac{P_{out}}{P_t} \right)^{\frac{\gamma-1}{\gamma}} \right] \right\}^4 d^8 \rho_s^2}{\rho_0 c_0^5 l^7} \right\}^{\frac{1}{2}} \quad (8)$$

Equation (8) shows that if the manned spacecraft cabin

experiences a leak where the diameter is d and thickness is l , the receiving sound pressure P_{rs} is closely related to leak size. In particular measure distance r and direction α , by the sound pressure measurement, we can determine the leak size.

C. The Center Frequency of the Leak Ultrasonic Signal

The leak acoustic spectrum is complex, the sensor cannot cover all wave band in measurement. To measure acoustic wave effectively and avoid noise disturbance, we should find the sound wave frequency. According to the research [9], the ultrasonic sound power spectrum is a function of Strouhal number fd/V , f is the ultrasonic frequency, d is the leak diameter, V is the outlet velocity. A lot of experiments shows that, the normalized Strouhal number $S = fd/V \cdot c/c_0$, c/c_0 is the correct coefficient, the ordinate is the power level

$$10 \log \left(\frac{1}{W} \frac{dW}{df} \frac{V}{d} \frac{c}{c_0} \right) dB$$

The normalized power spectrum is shown as Fig. 2, and the curve is experience curve.

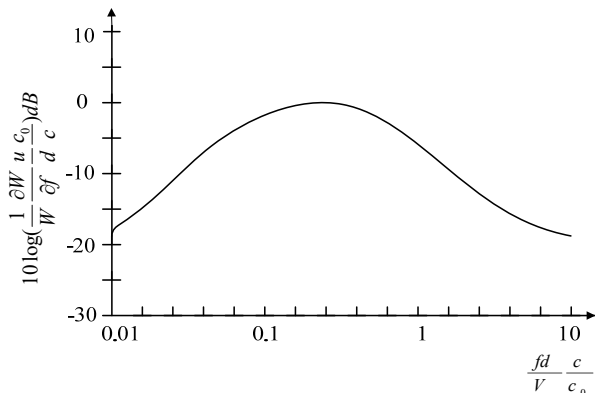

Fig. 2 Power spectrum of the acoustics signal caused by leak

The curve in Fig. 2 can approximate the curve (9)

$$y = \frac{4}{\pi} \frac{1}{(x+1/x)^2} \quad (9)$$

In the formula:

$$y = \frac{1}{W} \frac{\partial W}{\partial f} \frac{u}{d} \frac{c}{c_0}; \quad x = \frac{5fd}{u} \cdot \frac{C}{C_0}$$

In order to improve the detection sensitivity, and the peak power at the center frequency has maximum sensitivity, so take the derivative of formula in (9) as 0, we have:

$$y' = -\frac{8}{\pi} \frac{1}{(x+1/x)^3} \cdot \left(1 - \frac{1}{x^2}\right) = 0 \quad (10)$$

At $x=1$, y could get the maximum value, so the sound power gets peak value, the sound power can get the maximum value. In the normal temperature and standard atmosphere pressure

condition, the gas flow velocity from the cabin inside to the outside vacuum environment is about 295 m/s. The gas temperature change is small, so the temperature correction c/c_0 influence can be ignored. The center frequency of different leaks is shown in Table I.

TABLE I
CENTER FREQUENCY OF DIFFERENT DIAMETER OF LEAK SIGNAL

Leak diameter (mm)	0.3	0.4	0.8	1.0	1.5	2.0
Center frequency (kHz)	196.7	147.5	73.8	59.0	39.3	29.5

As shown in Table I, the frequency corresponding to max sound power is all bigger than 20 kHz, which means that all the signals are ultrasonic. The noise sound in the cabin environment can be avoided by detector, which can only check out ultrasonic signal.

III. EXPERIMENTAL VERIFICATION

In the experiment, we made a mobile platform with a leak detection sensor. When the platform moves, the distance between the leak acoustic sources and leak detection sensor changes. The leak detection sensor measure the sound pressure which produced by leak jet gas as Fig. 3, which is made up with ultrasonic sensor and amplifier circuit. The leak is set up to the vacuum container. The air jet into the vacuum container and produce sound in air. The different size leak can be changed with flapper valve as Fig. 4.

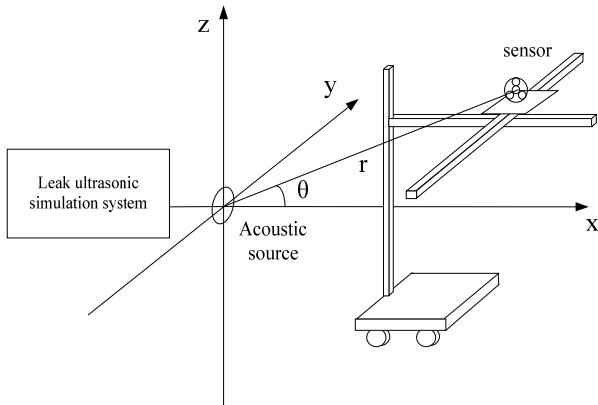

Fig. 3 Diagram of sound pressure test system

A. The Distance Test and Result Analysis

During the test, the ultrasonic detection sensor is placed on the bracket. Moving the distance between sensor and leak from 20 mm to 500 mm, we record the sound pressure. The diameter of 0.8 mm, 1.5 mm, and 2.0 mm leak change alternately. The test data are shown in Table II.

We paint the data of Table II in a two-dimensional chart, fit the data to a polynomial equation, and get the curve of three different leaks as Fig. 5 shows.

According to the data in Table II and Fig. 5, the accepted leak sound pressure signal value rapidly descends with the testing distance increasing, and this relationship is little different from the formula shown in (8), due to the air absorbability and

dispersion effect to make the sound transmitting away from the point source sphere wave module.

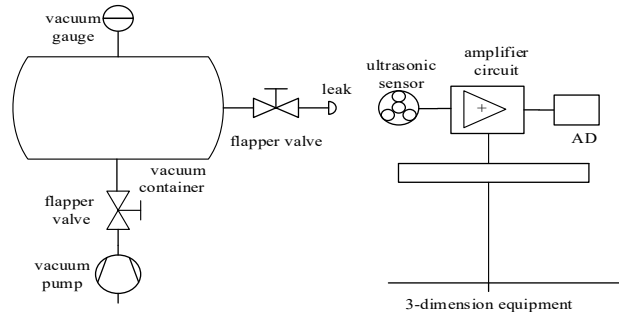

Fig. 4 Diagram of test system for ultrasonic leak detection

TABLE II
EXPERIMENT RESULTS OF SOUND PRESSURE CHANGING WITH DISTANCE

The distance between sensor and leak d (mm)	Sound pressure of different diameter leak P_{ps} (mV)		
	0.8mm	1.5mm	2.0mm
20	69.94	162.44	665.70
60	42.45	167.81	418.04
100	38.49	130.25	270.59
150	24.14	102.29	226.29
200	20.25	68.80	223.92
300	16.22	41.64	144.15
400	17.14	31.02	127.73
500	17.77	41.08	99.48

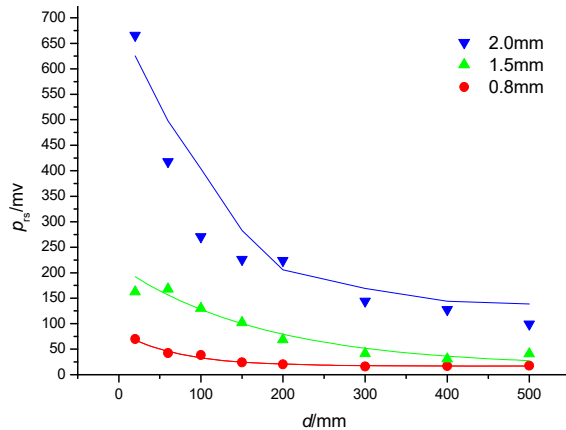

Fig. 5 Curve of sound pressure changing with the distance

1. Receiving Angle Test and Results Analysis

We set up a rotation flat as shown in Fig. 6 to measure sound pressures because of angle change between the normal of leak surface and the normal of receiving ultrasonic sensor surface. In Fig. 6, R is the radius, S is the area of receiver, S_c is the efficiency receiving area. So, we can acquire the formula in (11):

$$\alpha = \left| \arctan \left(\frac{l - R \sin c}{l_1 + R - R \cos c} \right) - c \right| \tag{11}$$

We tested sound pressure of sensor at the different angles,

and the results are shown in Table III.

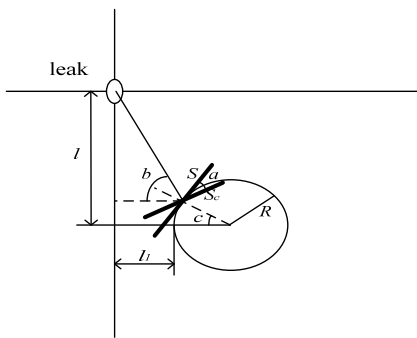

Fig. 6 Leak sound signal and testing angle

TABLE III
EXPERIMENT RESULTS OF SOUND PRESSURE SIGNAL WITH DIFFERENT TESTING ANGLE

Table rotation angle c (°)	Angle the normal of leak surface and the normal of receiving ultrasonic sensor surface.α(°)	Sound pressure P_p/mV			
		0.8mm	1.0mm	1.5mm	2.0mm
0	89	13.18	10.75	19.171	24.94
30	50	11.83	28.405	28.64	126.27
60	4	34.65	46.21	113.53	159.79
90	47	18.78	21.57	11.67	19.52

According to Table III, the sound pressure change by angle of different leaks can be drawn in Fig. 7, in which the y-coordinate is sound pressure, and the x-coordinate is the angle between sound source and receiver surface.

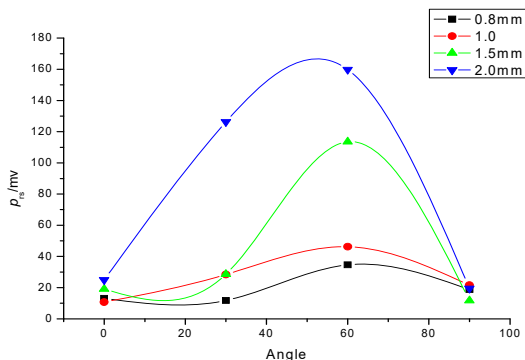

Fig. 7 Test result of the sound pressure for the ultrasonic receiving sensor on the rotation flat

According to (11), we can conclude that the corresponding value of α is 88.6° , 50° , 4° , 47° when the test angle is 0° , 30° , 60° , 90° , and the effective test area is correlation with cosine α , the corresponding value is 0.024, 0.643, 0.99, 0.681. The biggest sound pressure signal in the test is acquired at the angle of 60° , which is the same with theoretical value.

IV. THE DESIGN OF ULTRASONIC LEAK DETECTOR

Based on the theoretical analysis and test research, the ultrasonic sensor accepts the leak sound signal including leak dimension and testing angle information. To design the portable ultrasonic on-orbit Intravehicular leak detector, it must include some functions as the following:

- 1) Cabin and pipes leak detection and location and leak diameter evaluation.
- 2) Good interface, real-time showing, single handed operation.
- 3) Power charging through the cabin power supply and the interface meeting the requests.
- 4) On-orbit repair and replacing ability.

The most important function is the seal cabin and pipes leak detection and location. In the cabin, the detector can pick up the feeble leak ultrasonic signal in the complex environment and can rapidly find the leak location when the gas leaks from the cabin inside to the vacuum environment of cabin outside. The development of the detector can meet the requirement where on-orbit leak detection is operated in cabin and astronauts do not need to take a risk to go outside. And then, the detector can have the no-contact, large area, long-distance testing function. At the same time, it can detect the pipe leak belonging to the gas jet.

The leak detector consists of the sensor, mainframe, structure, preamplifier, DSP, display and key-press circuit, power supply and batteries. The system structure is shown in Fig. 8.

The portable ultrasonic leak detector sensor is the no-contact piezoelectricity ultrasonic sensor, and the laser and red photosensitive are used for testing the distance and point. The DSP is used as the core processor, and the leak ultrasonic signals are amplified by a four-class amplifier circuit for extracting the faint ultrasonic signal from the environment noise background, sending the analog signal to DSP circuit with embedded control precision of 3M 16bit AD, FFT transformation, character spectrum accumulation, character signal contrast and estimating leak size. The detector can show the result in LCD screen, and the leak diameter can be evaluated by the sound pressure connects with distance measurement by laser. And the detector belongs to the micro system, the software is developed by the C, and compiled into the hardware by CCS5.

The detector structure has the gun shape as shown in Fig. 9, the material is black ABS. It has Li battery (2200 mAh), switch and J599 charging interface.

Through the performance testing, it has some parameters: air→vacuum, Φ 0.3 mm leak, leak rate equivalent to $0.8Pa \cdot m^3/s$, (atmospheric side measurement), and sensing range is up to $100 mm \times 100 mm$ with a 0.3-mm diameter leak, and the position accuracy is better than 20 mm, measured weight is 1.0 kg, working power consumption is 2.2 W.

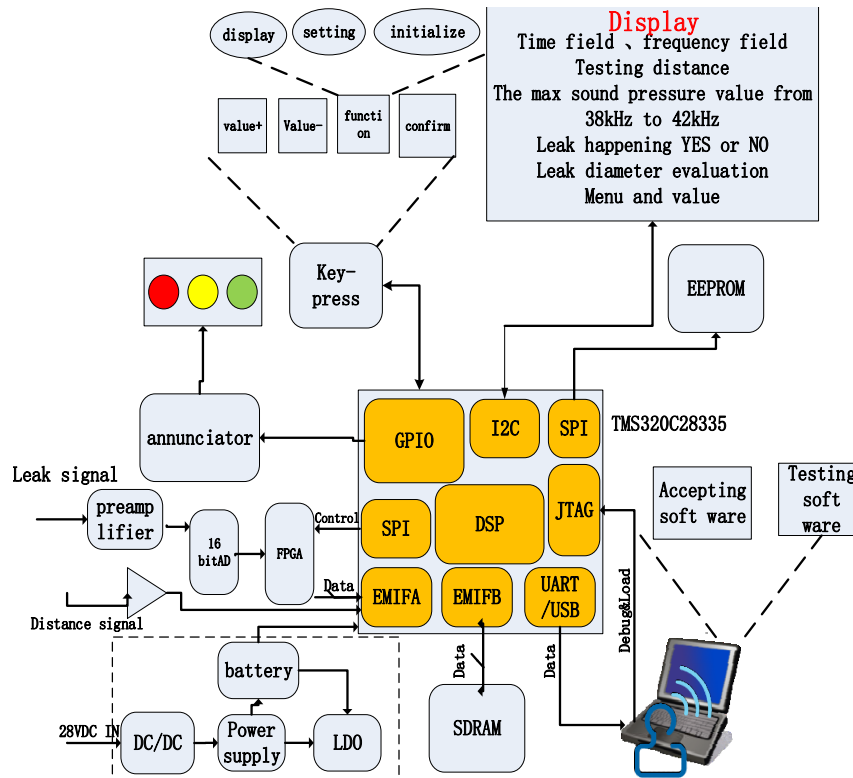

Fig. 8 Diagram of the portable ultrasonic leak detector



Fig. 9 Picture of the portable ultrasonic leak detector

V. CONCLUSION

The production, propagation, and detection of the leak ultrasonic signal on-orbit intravehicular for manned spacecraft are discussed. The relationship of sound power between leak diameter, testing distance, and detecting angle is acquired. And

the results are validated by some experimentation.

There are some conclusions as the following:

- 1) The leak ultrasonic power is related with leak diameter, and the center frequency is more than 20 kHz when the leak diameter is up to mm.
- 2) The leak ultrasonic pressure declines quickly as the testing distance is increasing.
- 3) Sensor accepting leak ultrasonic pressure is direct ratio correlation with cosine the angle between the sensor normal and the center line from sensor and leak.
- 4) The on-orbit detector sensitivity is up to $10^{-1} \text{ Pa}\cdot\text{m}^3$, location precision is better than 20 mm, the mass is letter than 1.0 kg, and the electric power is less than 2.2 W.

ACKNOWLEDGMENT

This work is supported by National Natural Science Foundation of China (No.U1537109).

REFERENCES

- [1] Yu Xinfu, Yan Rongxin. The research of leak testing technology in spacecraft on orbit (J). Spacecraft Environment Engineering, 2008, 25 (2), 177-182 (in Chinese).
- [2] Reusser R, Holland S D, Roberts R A. Array-based acoustic leak location in spacecraft structures (C).in AIP Conference Proceedings, 2006, 894: 1540-1547.
- [3] Holland S D, Roberts R, Chimenti D E, et al. Two-sensor ultrasonic spacecraft leak detection using structure-borne noise (C). Acoustics Research Letters Online, 2005, 6(2), 63-105.
- [4] Holland S D, Roberts R, Chimenti D E, et al. Leak detection in spacecraft using structure-borne noise with distributed sensors (J). Applied Physics

- Letters, 2005, 86: 174105.
- [5] Song Juoho, Holland D Stephen, Chimenti D E. A spherically focused capacitive-film air-coupled transducer (C). AIP conference, 2006, 820: 908-915.
 - [6] Holland S D, Roberts R, Chimenti D E, et al. An ultrasonic array sensor for spacecraft leak direction Finding (J). Ultrasonics, 2006, 45: 121-126.
 - [7] Yan Rongxin, Li Weidan. Design of portable leak detector used for manned spacecraft based on ultrasonic (C). 11th European Conference on Non-Destructive Testing (ECNDT 2014), October 6-10, 2014, Prague, Czech Republic.
 - [8] Zhang Qiang. Pneumatic Acoustics (M). Beijing National Defense Industry Press, 2012: 210-211 (in Chinese).
 - [9] Ma Dayou. Acoustic Manual (M). Beijing: Science Press, 1983:30-32(in Chinese).