

Application of Fractional Model Predictive Control to Thermal System

Aymen Rhouma, Khaled Hcheichi, Sami Hafsi

Abstract—The article presents an application of Fractional Model Predictive Control (FMPC) to a fractional order thermal system using Controlled Auto Regressive Integrated Moving Average (CARIMA) model obtained by discretization of a continuous fractional differential equation. Moreover, the output deviation approach is exploited to design the K -step ahead output predictor, and the corresponding control law is obtained by solving a quadratic cost function. Experiment results onto a thermal system are presented to emphasize the performances and the effectiveness of the proposed predictive controller.

Keywords—Fractional model predictive control, fractional order systems, thermal system.

I. INTRODUCTION

FRACTIONAL calculus is a mathematical discipline with a 300-years-old history. The goal was to extend the integration or derivation of fractional order by using not only integer orders but also fractional orders [1]. Later, on the 20th century Grünwald-Letnikov introduced the notion of a fractional-order discrete difference. In recent years, non integer order calculus, also known as fractional calculus, has attracted the attention of researcher in several fields such as engineering [2], biology [3], economics [4] etc. It was found that many physical systems have shown a dynamic behavior of non integer order, probably the first dynamic physical system to be widely recognized is the diffusion of heat into semi-infinite (thermal system), other fractional systems that are known, such as the viscoelastic systems, the electrode-electrolyte polarization, electromagnetic waves and many others [5]. The fractional system appears also in the process industries, in particular through application of modeling, identification and control [6], [7]. Moreover, the MPC has become a mature control strategy over the last few years. The reason of this success is attributed to the consideration of different types of constraints on input and output signals, and also it can handle a large class of systems such as open-loop unstable systems, non-minimum phase systems, delayed systems and multivariable systems [8]. Therefore, the model predictive control is widely encountered in the industrial processes [9]. The originality of this work lies in applying the MPC of fractional order systems. The system is approximated

with a direct method that is based on the numerical evaluation of non integer order operators. Consequently, a fractional order model is achieved and FMPC is developed.

II. FRACTIONAL ORDER SYSTEMS

Fractional order calculus is a generalization of differentiation and integration to non-integer orders operator ${}_{t_0}D_t^\alpha$ which is defined as:

$${}_{t_0}D_t^\alpha = \begin{cases} \frac{d^\alpha}{dt^\alpha} & \alpha > 0 \\ 1 & \alpha = 0 \\ \int_{t_0}^t (d\tau)^\alpha & \alpha < 0 \end{cases} \quad (1)$$

where α is the order, $\alpha \in \mathbb{R}$, t and t_0 are the upper and lower limits of the operation. The Grunwald-Letnikov's definition (GL) is the most popular definition to fractional order control and its application, it has defined as:

$${}_{t_0}D_t^\alpha f(t) = \lim_{h \rightarrow 0} \frac{1}{h^\alpha} \sum_{i=0}^{(t-t_0)/h} (-1)^i \binom{\alpha}{i} f(t-ih) \quad (2)$$

where h is the sampling period, and $\binom{\alpha}{i}$ means:

$$\binom{\alpha}{i} = \frac{\alpha(\alpha-1)\dots(\alpha-i+1)}{i!}.$$

The G-L definition of function $f(t)$ is defined as:

$${}_{t_0}D_t^1 f(t) = \lim_{h \rightarrow 0} \frac{f(t) - f(t-h)}{h} \quad (3)$$

Expression (2) may be used to numerically evaluate the integral or the derivative of fractional order using some suitably chosen value of sampling rate as follows [10].

$${}_{t_0}D_t^\alpha f(t) = \frac{1}{h^\alpha} \sum_{i=0}^{(t-t_0)/h} (-1)^i \binom{\alpha}{i} f(t-ih) \quad (4)$$

As $\binom{\alpha}{i}$ does not converge rapidly when α is a fractional, non integer operators are known to have a long memory behavior. For real implementation, by using the short memory principle [11], (4) can be rewritten using only the recent past values of $f(t)$ as [12]:

Aymen Rhouma is with the University Tunis EL Manar, Faculty of Sciences of Tunis, Conception and Control of Systems Laboratory 2092 - El Manar Tunis, Tunisia (e-mail: aymenrhouma1984@gmail.com).

Khaled Hcheichi and Sami Hafsi are with the University Tunis EL Manar, National Engineering School of Tunis, Conception and Control of Systems Laboratory 2092 - El Manar Tunis, Tunisia (e-mail: khaled.hcheichi213@gmail.com, samihafsi@ymail.com).

$${}_{t_0}D_t^\alpha f(t) = \frac{1}{h^\alpha} \sum_{i=0}^N (-1)^i \binom{\alpha}{i} f(t-ih) \quad (5)$$

where N is an integer equals to T/h .

The Laplace transform of G-L definition for zero initial conditions can be given as [13]:

$$L[{}_0D_t^\alpha f(t)] = s^\alpha L[f(t)] = s^\alpha F(s) \quad (6)$$

In general, a fractional model can be described by a fractional differential equation characterized by:

$$\sum_{l=0}^L a_l D_t^{\alpha_{a_l}} y(t) = \sum_{m=0}^M b_m D_t^{\alpha_{b_m}} u(t) \quad (7)$$

Using the Laplace transform in (5), the fractional-order system can be represented by the following transfer function:

$$G(s) = \frac{Y(s)}{U(s)} = \frac{\sum_{m=0}^M b_m s^{\alpha_{b_m}}}{\sum_{l=0}^L a_l s^{\alpha_{a_l}}} \quad (8)$$

where $(a_l, b_m) \in R^2$, $(\alpha_{a_l}, \alpha_{b_m}) \in R_+^2$.

The use of the numerical approximation, allows rewriting (5) as:

$$y(k) = \frac{1}{\sum_{l=0}^L \frac{a_l}{h^{\alpha_{a_l}}} \sum_{m=0}^M \frac{b_m}{h^{\alpha_{b_m}}} \sum_{i=0}^k (-1)^i \binom{\alpha_{b_m}}{i}} u(k-i) - \frac{1}{\sum_{l=0}^L \frac{a_l}{h^{\alpha_{a_l}}} \sum_{i=1}^k (-1)^i \binom{\alpha_{a_l}}{i}} y(k-i) \quad (9)$$

The objective of the next section is to propose the FMPC that is based on the use of a fractional order model which is obtained by using the direct method.

III. FRACTIONAL MODEL PREDICTIVE CONTROL

In this section, we introduce the needed steps to find the optimal control law using the new proposed approach of FMPC for the fractional systems. Consequently, the direct method represented in Section II of the fractional system will be used to obtain the fractional order model.

$$\Delta y(k) = \frac{1}{\sum_{l=0}^L \frac{a_l}{h^{\alpha_{a_l}}} \sum_{m=0}^M \frac{b_m}{h^{\alpha_{b_m}}} \sum_{i=0}^k (-1)^i \binom{\alpha_{b_m}}{i}} \Delta u(k-1-i) - \frac{1}{\sum_{l=0}^L \frac{a_l}{h^{\alpha_{a_l}}} \sum_{i=1}^k (-1)^i \binom{\alpha_{a_l}}{i}} \Delta y(k-i) + e(k) \quad (10)$$

$\Delta = 1 - q^{-1}$ is an integral action introduced in order to obtain, in closed loop, a nil steady state error.

By using (10), we obtain the predicted output of the system in $k+1$:

$$\hat{y}(k+1/k) = y_l(k+1) + \alpha_1 \Delta u(k) \quad (11)$$

where: $\alpha_1 = \frac{1}{\sum_{l=0}^L \frac{a_l}{h^{\alpha_{a_l}}} \sum_{m=0}^M \frac{b_m}{h^{\alpha_{b_m}}}}$ and $y_l(k+1)$ is the free

response of the system:

$$y_l(k+1) = y(k) + \frac{1}{\sum_{l=0}^L \frac{a_l}{h^{\alpha_{a_l}}} \sum_{m=0}^M \frac{b_m}{h^{\alpha_{b_m}}} \sum_{i=1}^{k+1} (-1)^i \binom{\alpha_{b_m}}{i}} \Delta u(k-i) - \frac{1}{\sum_{l=0}^L \frac{a_l}{h^{\alpha_{a_l}}} \sum_{i=1}^{k+1} (-1)^i \binom{\alpha_{a_l}}{i}} \Delta y(k+1-i) \quad (12)$$

The 2-step ahead predictor is given by:

$$\hat{y}(k+2/k) = y(k+1) + \alpha_1 \Delta u(k+1) + \beta_1 \Delta u(k) + \beta_2 \Delta y(k+1) + \delta_1 - \delta_2 \quad (13)$$

where: $\beta_1 = \frac{-1}{\sum_{l=0}^L \frac{a_l}{h^{\alpha_{a_l}}} \sum_{m=0}^M \frac{b_m}{h^{\alpha_{b_m}}} \alpha_{b_m}}$; $\beta_2 = \frac{1}{\sum_{l=0}^L \frac{a_l}{h^{\alpha_{a_l}}} \sum_{i=0}^L \frac{a_l}{h^{\alpha_{a_l}}} \alpha_{a_l}}$,

$\delta_1 = \frac{1}{\sum_{l=0}^L \frac{a_l}{h^{\alpha_{a_l}}} \sum_{m=0}^M \frac{b_m}{h^{\alpha_{b_m}}} \sum_{i=2}^{k+2} (-1)^i \binom{\alpha_{b_m}}{i}} \Delta u(k+1-i)$;

$\delta_2 = \frac{1}{\sum_{l=0}^L \frac{a_l}{h^{\alpha_{a_l}}} \sum_{i=2}^{k+2} (-1)^i \binom{\alpha_{a_l}}{i}} \Delta y(k+2-i)$ as:

$\Delta y(k+1) = y(k+1) - y(k)$ then:

$$\hat{y}(k+2/k) = (1 + \beta_2) y(k+1) + \alpha_1 \Delta u(k+1) + \beta_1 \Delta u(k) - \beta_2 y(k) + \delta_1 - \delta_2$$

If we replace $\hat{y}(k+1/k)$ by its expression (13), we obtain:

$$\hat{y}(k+2/k) = (1 + \beta_2) y_l(k+1) + \alpha_2 \Delta u(k) + \alpha_1 \Delta u(k+1) - \beta_2 y(k) + \delta_1 - \delta_2 \quad (14)$$

where: $\alpha_2 = ((1 + \beta_2) \alpha_1 + \beta_1)$. We set: $y_l(k+2) = (1 + \beta_2) y_l(k+1) - \beta_2 y(k) + \delta_1 - \delta_2$ then

$$\hat{y}(k+2/k) = y_l(k+2) + \alpha_1 \Delta u(k+1) + \alpha_2 \Delta u(k) \quad (15)$$

Consequently, the expression of the j -step ahead predictor $\hat{y}(k + j / k)$ is as:

$$\hat{y}(k + j / k) = \sum_{i=1}^j \alpha_{j-i+1} \Delta u(k+i-1) + y_l(k+j) \quad (16)$$

The future control sequence over a control horizon H_c is computed by minimizing a cost function which indicates how well the process follows the desired trajectory. This function can be expressed by the future errors between output signals and setpoints, and the future incremental control signals. The cost function is given by:

$$J = \sum_{j=1}^{H_p} (\hat{y}(k + j / k) - y_c(k+j))^2 + \lambda \sum_{i=0}^{H_c-1} \Delta u(k+i)^2 \quad (17)$$

The output sequence on the prediction horizon H_p is written as:

$$Y = G\Delta U + Y_l \quad (18)$$

where:

$$G = \begin{bmatrix} \alpha_1 & 0 & 0 \cdots 0 \\ \alpha_2 & \alpha_1 & 0 \cdots 0 \\ \vdots & \vdots & \ddots \\ \alpha_{H_p} & \alpha_{H_p-1} & \cdots \alpha_{H_p-H_c+1} \end{bmatrix}$$

and $\begin{cases} Y = [\hat{y}(k+1/k), \dots, \hat{y}(k+H_p/k)]^T \\ \Delta U = [\Delta u(k), \dots, \Delta u(k+H_c-1)]^T \\ Y_l = [y_l(k+1), \dots, y_l(k+H_p)]^T \end{cases}$

The cost function of (17) is expressed as:

$$J = (G\Delta U + Y_l - Y_c)^T (G\Delta U + Y_l - Y_c) + \lambda \Delta U^T \Delta U \quad (19)$$

where λ is the weighting factor, Y_c is the sequence of set-points on the prediction horizon.

Minimizing (19), we obtain the optimal control sequence.

$$\Delta U = [G^T G + \lambda I]^{-1} G^T [Y_c - Y_l] \quad (20)$$

IV. PRACTICAL RESULTS

This section provides an application of the predictive control proposed in this paper (FMPC) to a thermal system depicted in Fig. 1. Indeed, this system can be defined with fractional order model [14], [15].

The thermal system is composed by an aluminum rod of 41 cm length and 2 cm of section heated by a resistor. The input signal of this system is the voltage applied to the power circuit feeding the heating resistor, and the output is the rod temperature measured with a distance 'd' from the heated surface by an LM35DZ sensor, expressed by a voltage varying from 0v to 5v.

Several approaches have been proposed to model the

phenomenon of a thermal system. A solution was proposed by Cois [16], it is to show that the model of this phenomenon is of fractional order medium which has a commensurable order of 0.5.

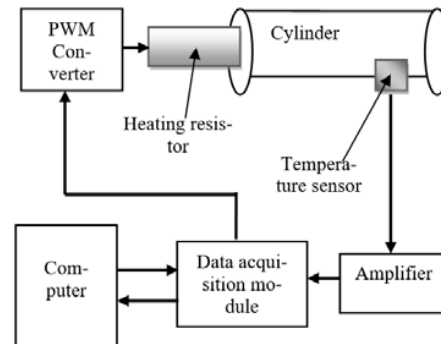

Fig. 1 Thermal system

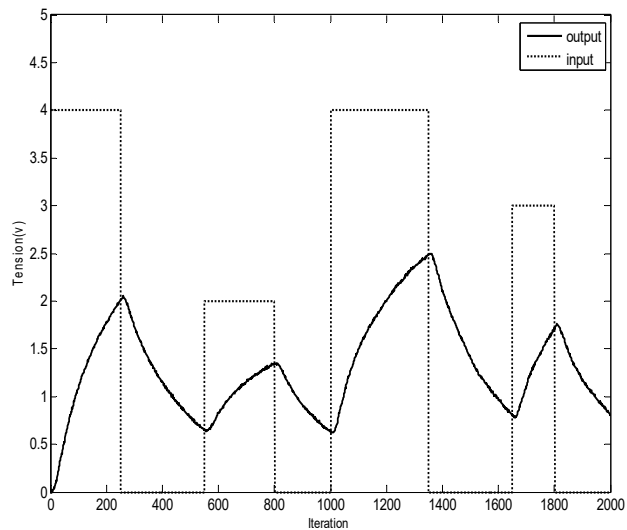

Fig. 2 Identification data

To model the thermal system, the injected input signal is a pseudo random binary sequence (PRBS) varying from 0v to 5v, as given in Fig. 2. The simplified, refined instrumental variable for continuous-time fractional models (SRIVCF) method [17] is used for the identification of the system based on measurement data plotted in Fig. 2. Based in these results, a time lag is illustrated between the heating resistor and the temperature measurement, probably due to the flux diffusion in the medium. Therefore, by using the SRIVCF method, we were able to determine the fractional order model which is given by:

$$H(s) = \frac{0.5623}{506.2843s^{1.5} + 135.3925s + 6.3598s^{0.5} + 1} e^{-100s} \quad (21)$$

The objective of the control system is to maintain the temperature at a desired value. In all experiences, the sample time is equal to 40 sec. Firstly, we have applied the model

predictive control based on fractional model (FMPC) with the following design parameters: $H_p = 8$, $H_c = 1$ and $\lambda = 0.2$. The obtained experimental results are plotted in Fig. 3.

Based on practical results shown in Fig. 3, it is clear that the temperature follows the desired setpoints. Consequently, these results show good performances of the proposed approach.

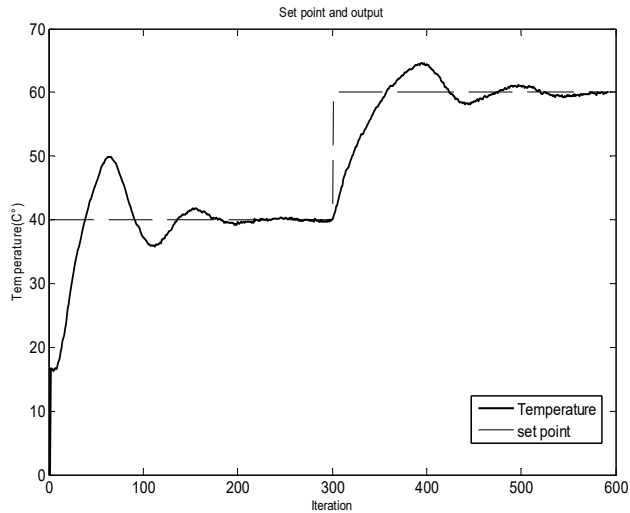

(a)

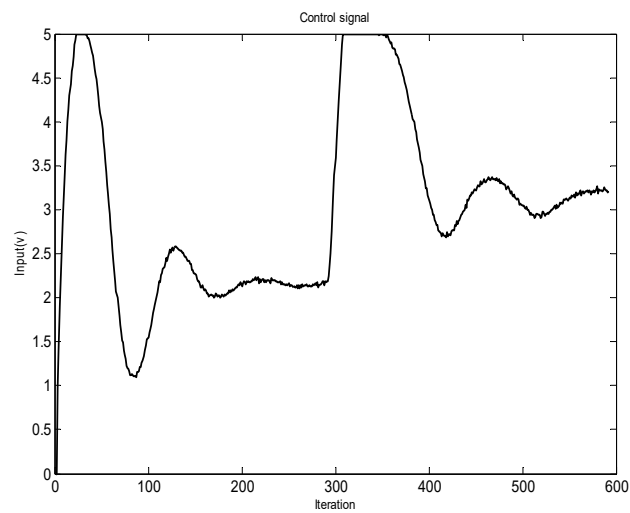

(b)

Fig. 3 Closed-loop results for FMPC with $H_p = 8$. (a) setpoint and output, (b) Control Signal)

In these experiences, the control signal is saturated and attained the maximal value. In order to avoid the control input saturation, we have introduced a model for the sequence of setpoints, which is given by:

$$H_c(s) = \frac{1}{1 + \tau \cdot s} \quad (22)$$

The constant τ is used to modify the closed loop dynamic

system. In this case, we choose this constant equals to 2800 sec. The evolutions of the set point, the control signal and the measured temperature (output signal) obtained with the proposed MPC with $H_p = 12$ are represented in Fig. 4. Based in these results, we notice that the measured temperature meets the desired requirements. We remark also that the control signal is not saturated.

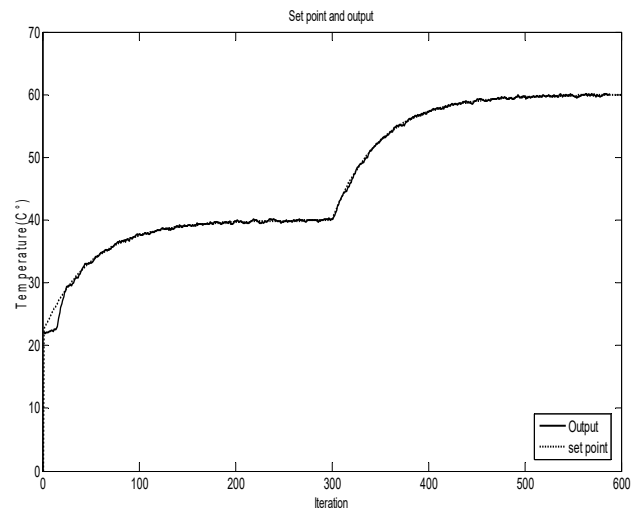

(a)

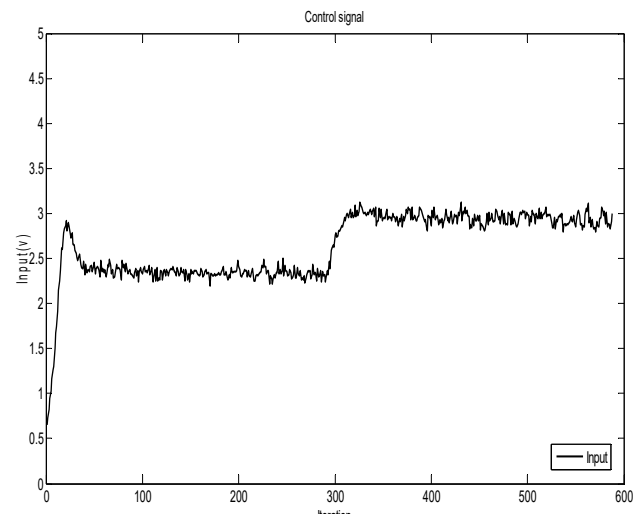

(b)

Fig. 4 Closed-loop results for FMPC with $H_p = 12$. (a) set point and output, (b) Control Signal)

V. CONCLUSION

In this paper, a new method of FMPC has been introduced. This method consists to obtain a fractional order model from the fractional system. Therefore, the output deviation approach is used to design the j-step ahead output predictor and the control law is obtained by solving a quadratic cost function. Experimental results on a thermal system show that the

predictive controller using a fractional order model exhibits good performance and it is more efficient than the classical MPC. Indeed, the control law obtained by the FMPC algorithm is more smooth than one obtained by MPC.

REFERENCES

- [1] Bagley R., Calico R. Fractional order state equations for the control of viscoelastically damped structures. *Journal of Guidance, Control, and Dynamics*, 1991, 14:304–311.
- [2] Zhang Y., Tian Q., Chen L., Yang J. Simulation of a viscoelastic flexible multibody system using absolute nodal coordinate and fractional derivative methods. *Multibody System Dynamics*, 2009, 21:281–303.
- [3] Yuste S., Abad E., Lindenberg K. Application of fractional calculus to reaction-subdiffusion processes and morphogen gradient formation. Arxiv preprint arXiv 2010, 1006.2661.
- [4] Mainardi F., Raberto M., Gorenflo R., Scalas E. Fractional calculus and continuous-time finance II: the waiting-time distribution. *Physica A: Statistical Mechanics and its Applications*, 2000, 287:468–481.
- [5] Sun H.H., Charef A., Tsao Y., Onaral B. Analysis of polarization dynamics by singularity decomposition method. *Annals of Biomedical Engineering*, 1992,20:321-335
- [6] Shantanu D. *Functional fractional calculus for system identification and controls*. Springer-verlag, Berlin, 2008.
- [7] Victor S., Malti R., Melchior P., Oustaloup A. Instrumental Variable Identification of Hybrid Fractional Box-Jenking Models, 18th IFAC World Congress, Milano (Italy),2011.
- [8] Fukushima H., Kim T., Sugie T. Adaptive model predictive control for a class of constrained linear systems based on comparison model. *Automatica*, 2007, 43(2):301–308.
- [9] Camacho E.F., Bordons C. *Model Predictive Control*. Springer-Verlag, Berlin, 2004.
- [10] Tavazoei, M.S. A note on fractional-order derivatives of periodic functions. *Automatica* 2010, 46:945–948.
- [11] Trigeassou J.C., Poinot P., Lin J., Oustaloup A., Levron F. Modelling and identification of a non integer order system, In *ECC, Karlsruhe, Germany*, 1999.
- [12] Oustaloup A. *la dérivation non-entiere*. Hermès-Paris, 1995.
- [13] Oustaloup A., Levron F., Mathieu B., Nanot F.M. Frequency band complex non integer differentiator: characterization and synthesis. *IEEE Transactions on Circuits and Systems I: Fundamental Theory and Applications*, 2000, 47:25–40.
- [14] Miller K.S., Ross B. *An introduction to the fractional calculus and fractional differential equation*. John Wiley and Son, 1993.
- [15] Oustaloup A., Olivier C., Ludovic L. *Représentation et Identification Par Modèle Non Entier*. Paris: Lavoisier; 2005.
- [16] Cois O. *Systèmes linéaires non entiers et identification par modèle non entier: application en thermique*. PhD thesis, Université Bordeaux1, Talence, 2002.
- [17] Malti R., Victor S., Oustaloup A., Garnier H. An optimal instrumental variable method for continuous-time fractional model identification. In *17th IFAC World Congress*, 14379–14384. Seoul South Korea, July 2008.