

# Iterative Learning Control of Two Coupled Nonlinear Spherical Tanks

A. R. Tavakolpour-Saleh, A. R. Setoodeh, E. Ansari

**Abstract**—This paper presents modeling and control of a highly nonlinear system including, non-interacting two spherical tanks using iterative learning control (ILC). Consequently, the objective of the paper is to control the liquid levels in the nonlinear tanks. First, a proportional-integral-derivative (PID) controller is applied to the plant model as a suitable benchmark for comparison. Then, dynamic responses of the control system corresponding to different step inputs are investigated. It is found that the conventional PID control is not able to fulfill the design criteria such as desired time constant. Consequently, an iterative learning controller is proposed to accurately control the coupled nonlinear tanks system. The simulation results clearly demonstrate the superiority of the presented ILC approach over the conventional PID controller to cope with the nonlinearities presented in the dynamic system.

**Keywords**—Iterative learning control, spherical tanks, nonlinear system.

## I. INTRODUCTION

CONTROL of nonlinear processes is the main challenge in large variety of petroleum refineries and chemical process industries. One of these nonlinear processes can be regarded as the level control problem in nonlinear tanks. It is known that when the cross-sectional area of a tank is varied as a function of the height of the containing liquid, the nonlinear terms will be appeared in the governing differential equation [1]. Recently, many researches have been conducted to cope with this latest issue in details. Keerthana et al. [1] investigated the fluid level control in a nonlinear conical tank. In the mentioned work, diverse control techniques such the Ziegler-Nichols, Tyreus-Luyben, and Cohen-Coon methods were used to control the liquid level in the conical tank. By resorting to the modern control concept, Tavakolpour-Saleh and Jokar [2] investigated the fluid level control in a nonlinear conical tank using a gain-scheduling adaptive control incorporating a fuzzy logic observer. They compared the obtained results to those of the conventional PID controller. Xavier et al. [3] investigated the fluid level control in a spherical tank using a conventional PID controller. They adjusted this controller by different methods such as Tyreus-

Luben (TL), Skogestad (SK), model predictive control (MPC), and Chien-Hrones-Reswick (CHR) methods. Among these methods, MPC settled faster and had a lower value of peak overshoot. Ramya et al. [4] investigated the fluid level control in a spherical tank using a PID controller. They compared Zeigler-Nichols tuning rule to the international model-based tuning rule of the PID controller. Kumar and Meenakshipriya [5] considered modeling and control of an interacting spherical two-tank system using a gain-scheduled PI controller. Based on the values of parameters in the operating region and different tuning methods, they designed the gain-scheduled PI controller for controlling the liquid level in the tank process. Christy et al. [6] considered modeling and control of interacting spherical and conical tanks system using a manually-tuned PID as well as a Honeywell PID controller. Accordingly, the non-linear tank was linearized about five equilibrium points using five second-order linear systems and then, PID controller parameters were obtained for each linear system using manual tuning method [6].

This research strives to presents another alternative to liquid level control of a nonlinear spherical two-tank system based on ILC scheme. The effectiveness of the ILC is then demonstrated through simulation. Finally, the simulation results are compared to those of the conventional PID controller through which the effectiveness of the proposed iterative learning controller is demonstrated.

## II. MODELING OF NONLINEAR TANKS SYSTEM

In this work, a spherical two-tank system was considered as a MIMO process in which the levels  $h_1$  and  $h_2$  pertaining to tanks 1 and 2 were considered as measured variables and  $F_{in1}$  and  $F_{in2}$  as manipulated variables. This process is shown in Fig. 1. Therefore, the dynamics of the tanks system can be formulated using the principle of mass conservation as [6], [7]:

$$\frac{\text{Mass accumulation}}{\text{time}} = \frac{\text{input mass}}{\text{time}} - \frac{\text{output mass}}{\text{time}}$$

Thus

$$\text{For tank 1 : } \frac{dm^1}{dt} = \frac{dm_{out}^1}{dt} - \frac{dm_m^1}{dt} \quad (1a)$$

$$\text{For tank 2 : } \frac{dm^2}{dt} = \frac{dm_{out}^2}{dt} - \frac{dm_m^2}{dt} \quad (1b)$$

A. R. Tavakolpour-Saleh is with the Department of Mechanical and Aerospace Engineering, Shiraz University of Technology, Shiraz, Iran (corresponding author, phone: +98 917 314 7796; fax: +98 713 7264102; e-mail: tavakolpour@sutech.ac.ir).

A. R. Setoodeh is with the Department of Mechanical and Aerospace Engineering, Shiraz University of Technology, Shiraz, Iran, (corresponding author, phone: +98 917 302 4021; fax: +98 713 7264102; e-mail: setoodeh@sutech.ac.ir).

E. Ansari is PHD student in Department of Mechanical and Aerospace Engineering, Shiraz, Iran (e-mail: e.ansari@sutech.ac.ir).

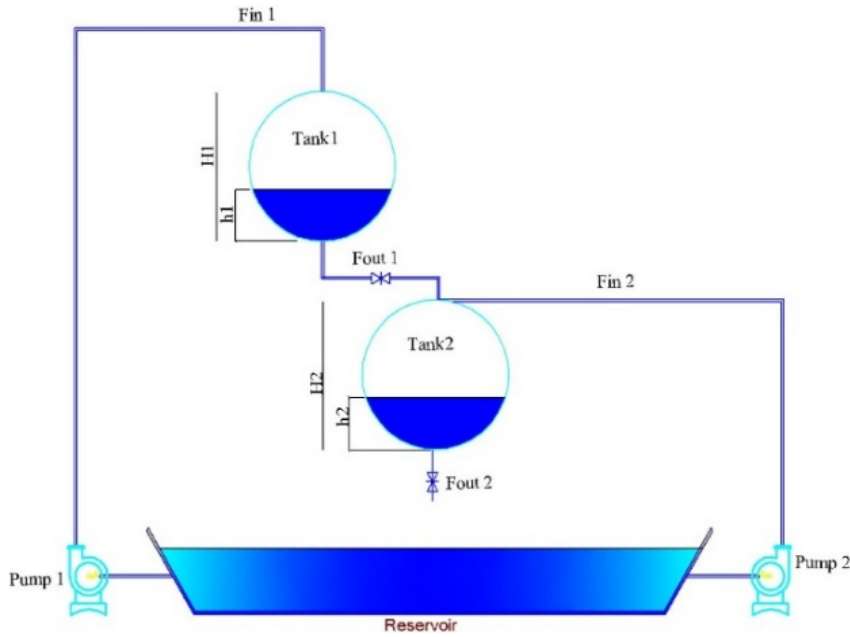

Fig. 1 Schematic diagram of the non-interacting spherical two-tank system

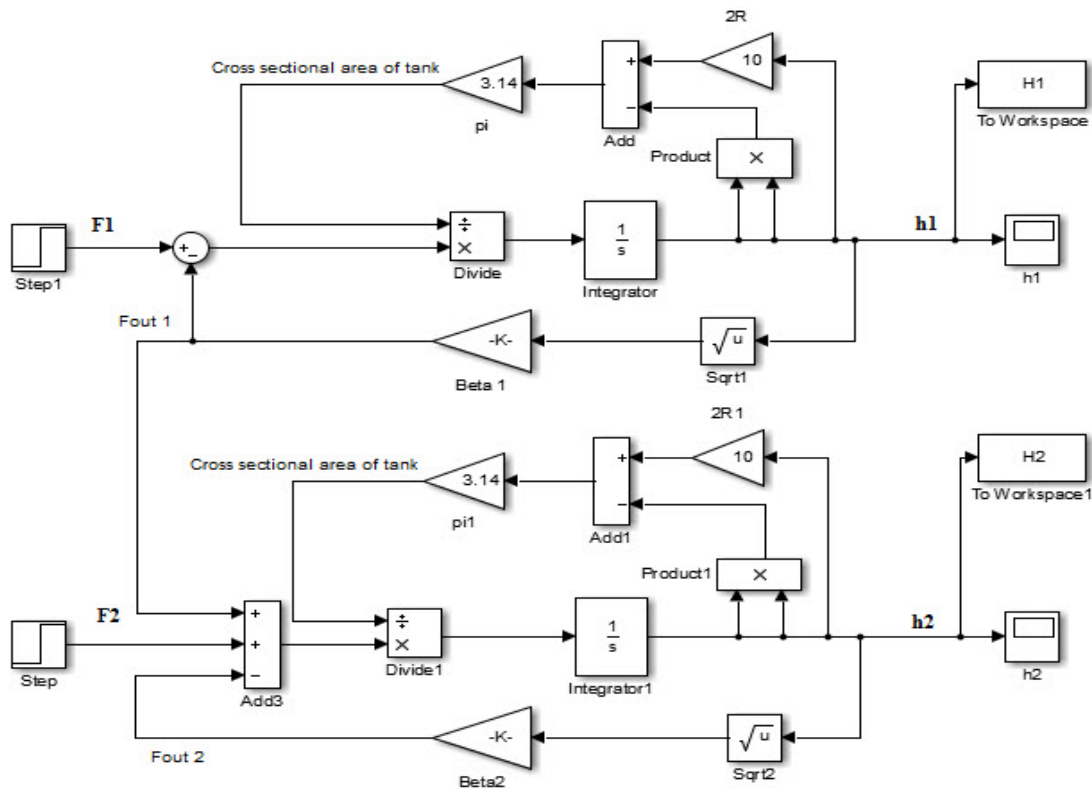

Fig. 2 Block diagram of the open loop system

where  $m^i$  is accumulated mass in each tank,  $m_{in}$  was the input liquid mass, and  $m_{out}$  was the output liquid mass. It was assumed that the fluid was incompressible, and the fluid density was constant. Based on these assumptions,

$$\text{For tank 1 : } \frac{dV_1}{dt} = F^1_{in} - F^1_{out} \quad (2a)$$

$$\text{For tank 2 : } \frac{dV_2}{dt} = F^2_{in} - F^2_{out} \quad (2b)$$

where  $V_i$  was the liquid volume accumulated in each spherical tank and  $F_{in}$  and  $F_{out}$  were the volumetric flow rates at inlet and outlet of each tank respectively as shown in Fig 1. Since  $dV = Adh$ :

$$\text{For tank 1 : } A_1(h_1) \frac{dh_1}{dt} = F_{in}^1 - F_{out}^1 \quad (3a)$$

$$\text{For tank 2 : } A_2(h_2) \frac{dh_2}{dt} = F_{in}^2 - F_{out}^2 \quad (3b)$$

Besides, the area of the fluid free surface in the tanks 1 and 2 could be expressed as functions of liquid heights  $h_1$  and  $h_2$ :

$$A_2 = \pi(2R_1h_2 - h_2^2) \quad (4a)$$

$$A_1 = \pi(2R_1h_1 - h_1^2) \quad (4b)$$

According to [2], the outlet flow of each tank could be written in a compact form as:

$$F_{out1} = \beta_1\sqrt{h_1} \quad (5a)$$

$$F_{out2} = \beta_2\sqrt{h_2} \quad (5b)$$

Finally, for the non-interacting spherical two-tank system the overall coupled differential equations were extracted:

$$\pi(2R_1h_1 - h_1^2) \frac{dh_1}{dt} = F_{in}^1 - \beta_1\sqrt{h_1} \quad (6a)$$

$$\pi(2R_1h_2 - h_2^2) \frac{dh_2}{dt} = F_{in}^2 + \beta_1\sqrt{h_1} - \beta_2\sqrt{h_2} \quad (6b)$$

III. OPEN-LOOP SIMULATION OF THE PROCESS

In order to simulate the obtained mathematical model of the process (see (6a) and (6b)), values of plant parameters were needed. Table I summarizes the parameters value considered in the simulation study. The block diagram of the open loop system in Simulink environment was shown in Fig. 2.

TABLE I  
VALUES OF SIMULATION PARAMETERS

Symbol	Description	Value
$R_1$	Radius of spherical tank 1	5m
$R_2$	Radius of spherical tank 2	5m
$D1$	Diameter of spherical tank 1	10m
$D2$	Diameter of spherical tank 2	10m
$H1$	Height of spherical tank 1	10m
$H2$	Height of spherical tank 2	10m
$\beta1[S]$	Valve coefficient for tank 1	0.001969 m2/sec
$\beta1[S]$	Valve coefficient for tank 2	0.001969 m2/sec

Figs. 3 (a) and (b) respectively demonstrate the dynamic response of Tanks 1 and 2 corresponding to a unit step input. It is obvious that the open-loop responses of the tanks could

not track the reference commands. Furthermore, the system response could not achieve the steady state conditions within the considered simulation time.

TABLE II  
VALUES OF PI CONTROLLER PARAMETERS

Parameter Value	$K_p$	$K_i$
	50000	500

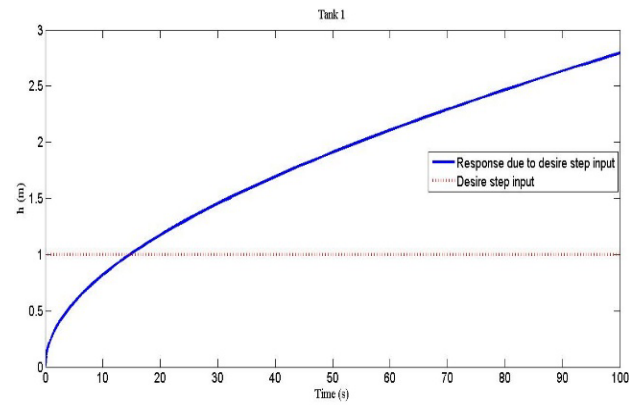

(a)

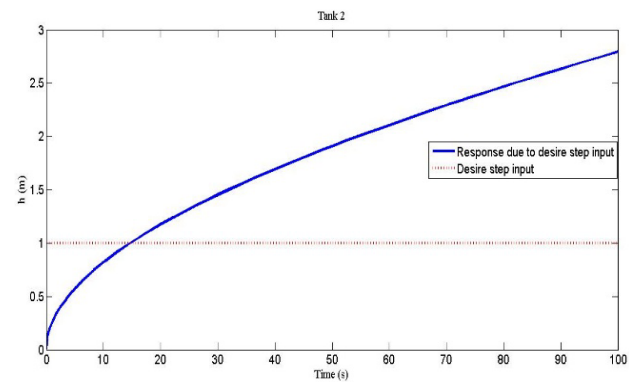

(b)

Fig. 3 Open loop responses of the nonlinear tanks corresponding to unit step reference (a) Tank 1 (b) Tank 2

IV. CLOSED LOOP SIMULATION OF PI CONTROL

For controlling the mentioned nonlinear process, the PID controllers were first considered. Among them, the PI control algorithm was selected and its parameters were found through a trial and error scheme so that a desired time constant of the system response corresponding to a unit step input was obtained. The PI controller parameters were shown in Table II. The block diagram of the closed loop PI control system was demonstrated in Fig. 4. Figs. 5 (a) and (b) demonstrate the closed loop responses of the tanks using the PI controller based on the parameters values demonstrated in Table II. It can be seen that although the tuned PI controller followed the unit reference effectively, it was not able to follow other higher values of the reference command (i.e. the liquid level of 9 m). Consequently, another effective closed loop controller

such as the so-called ILC was employed to cope with the nonlinearities of the dynamic system.

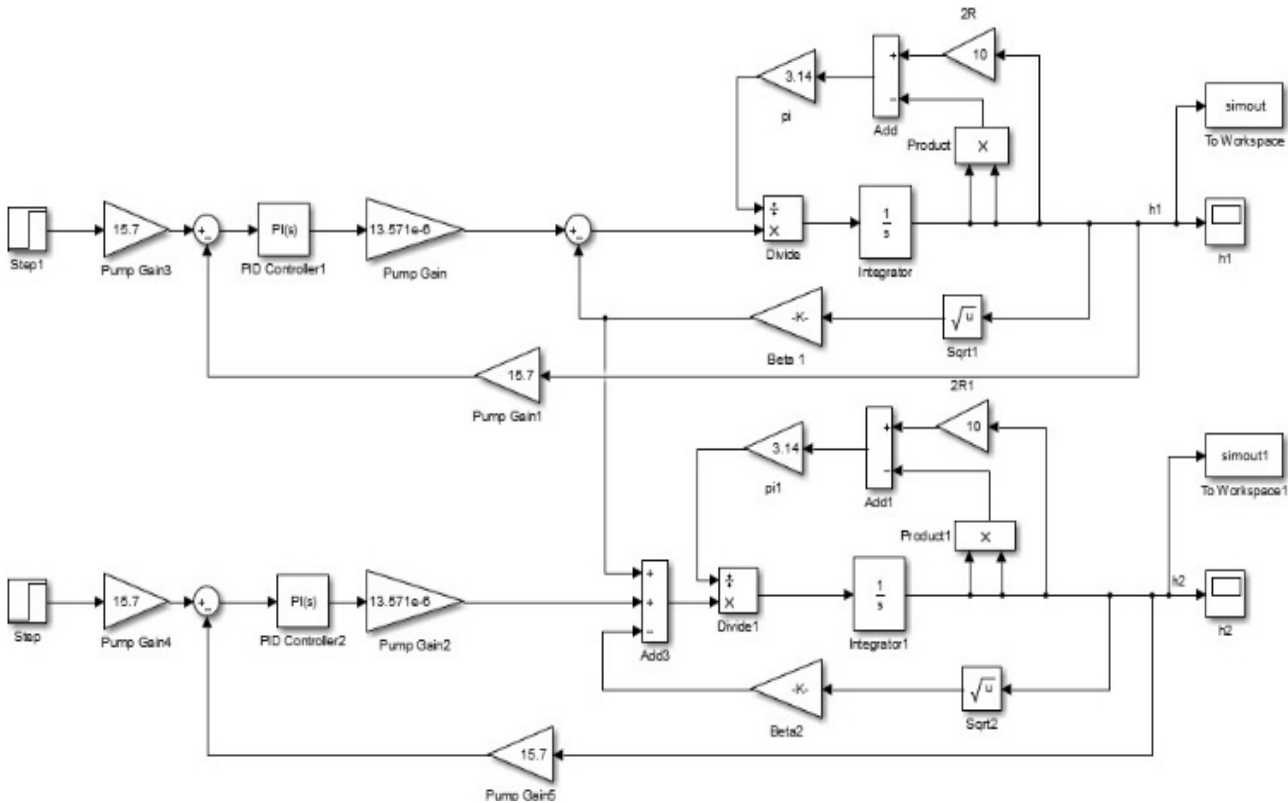

Fig. 4 Simulink block diagram of the closed loop PI control system

V. ITERATIVE LEARNING CONTROL

The iterative learning algorithm (ILA) is known as an adaptive control strategy through which the performance of a dynamic or control system becomes better and better based on some error criteria. ILA is based on the notion that the performance of a system that enforces the same duty multiple times can be amended by learning from prior executions [8]. For example, a basketball player shooting a free throw from a fixed position can improve his or her ability by practicing the shot frequently. During each shot, the basketball player perceives the path of the ball and purposely plans a variation in the shooting motion for the next attempt. As the player continues to practice, the correct motion is learned and becomes firmly fixed into the muscle memory so that the shooting accuracy is iteratively improved. The converged muscle motion profile is a control action generated through repetition and learning. This type of control strategy is the essence of ILA. Fig. 6 demonstrates a schematic of the P-type ILA.

The input signal  $u_k$  and the output signal  $y_k$  are stored in memory each time the system operates. The learning algorithm then evaluates the system performance error,  $e_k = y_d - y_k$  where  $y_d$  is the desired output of the system. Based on this error signal, the learning algorithm then

computes a new input signal  $u_{k+1}$ , which is stored for use in the next trial, i.e., the next time instant the system operates. The next input command is selected in such a way that it causes the performance error to be reduced on the next trial or iteration. According to Fig. 6, the next value of the input signal  $u_{k+1}$  can be expressed as:

$$u_{k+1} = u_k + \Phi e_k \tag{6a}$$

where  $\Phi$  is the proportional learning parameter. The ILA was thus applied to the fluid level control problem of the coupled nonlinear tanks and the dynamic response of the proposed feedback control system was investigated through simulation. The block diagram of the closed loop p-type ILA is demonstrated in Fig. 7.

The simulation study was carried out considering two operating modes of the controller. Regulation and servo modes were thus considered and then, the system response to a fixed desired reference was investigated.

A. Simulation Results of ILC in Regulation Mode

In the regulation mode, the set-point of the controller needs to be constant while the process is varying. In the operating range of up to 10 meter, the performance of this controller was investigated and the system response corresponding to step

references with different amplitudes were simulated as shown in Fig. 8. As can be observed, the ILC possesses an acceptable performance for all values of the set-point in both tanks.

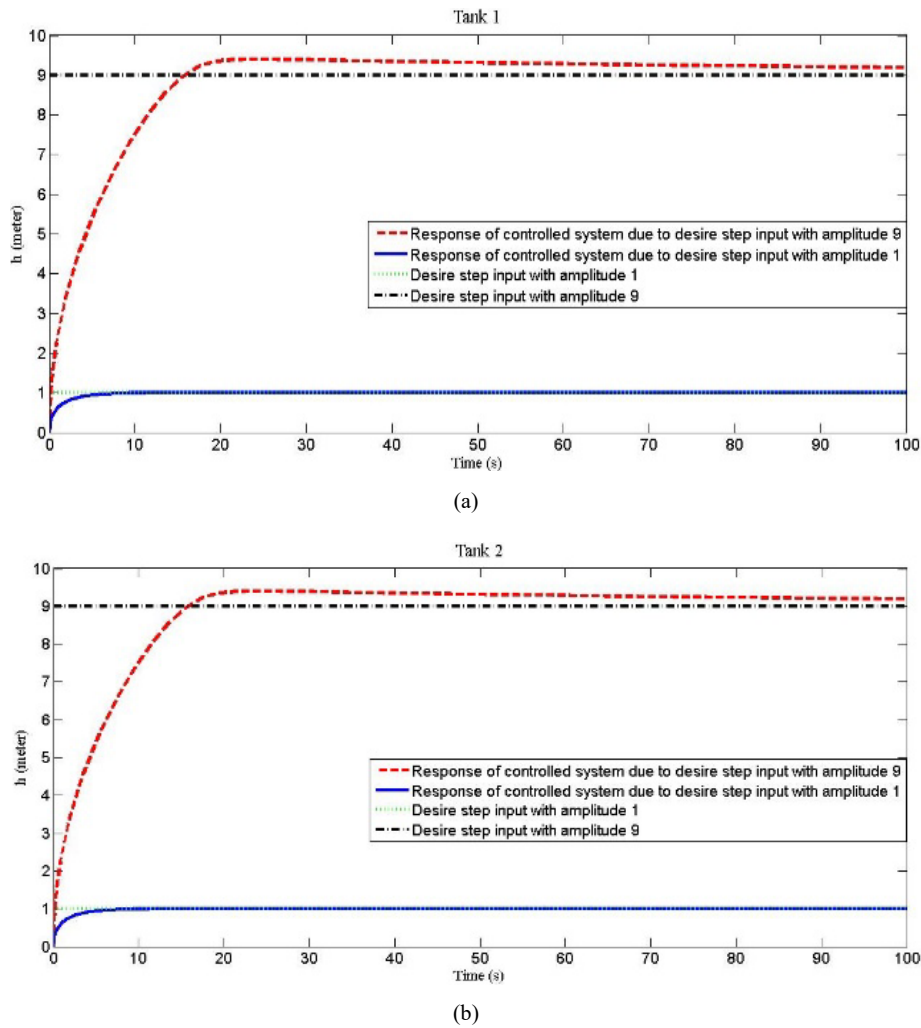

Fig. 5 Closed loop responses of control system (a) Tank 1 (b) Tank 2

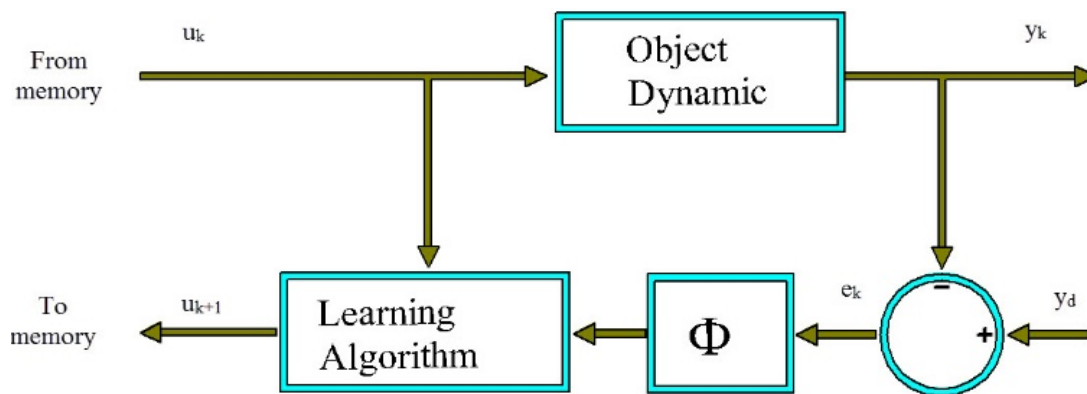

Fig. 6 Block diagram of the ILC

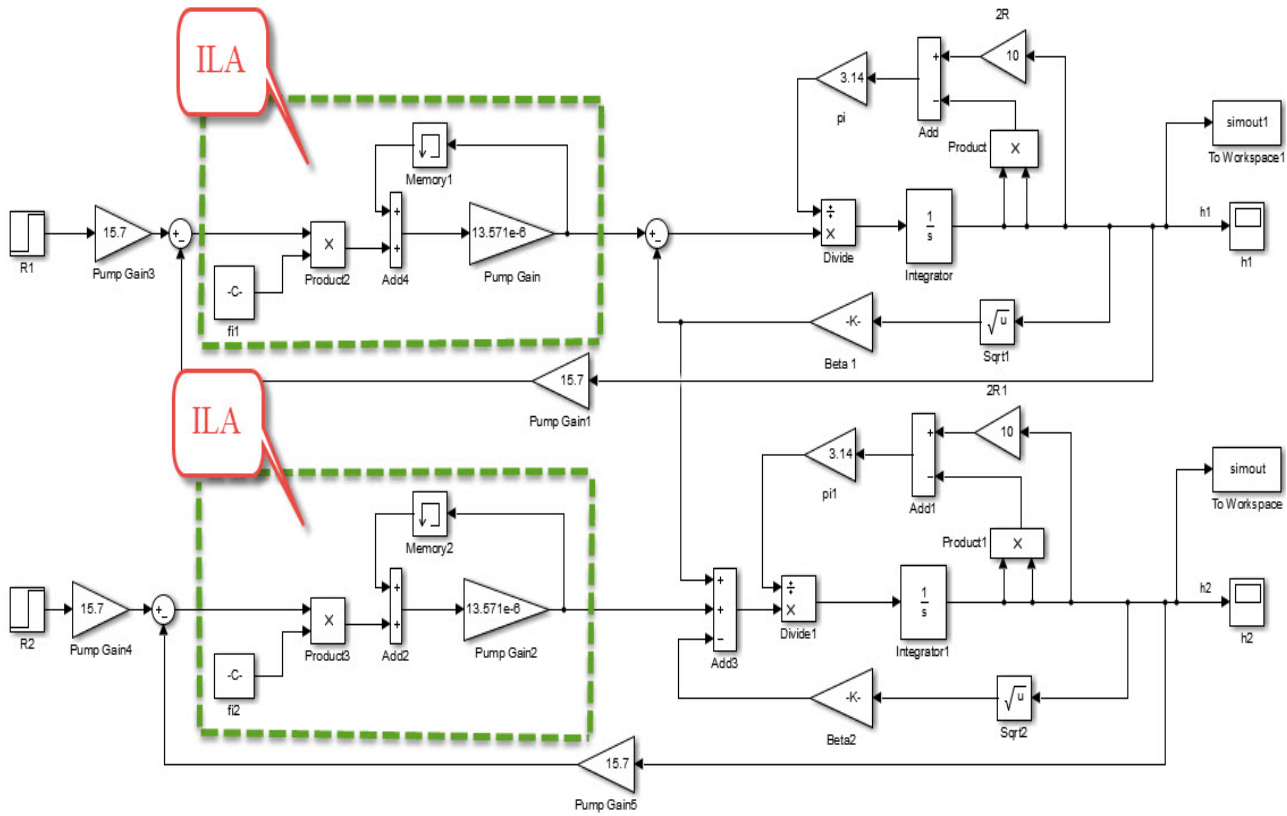
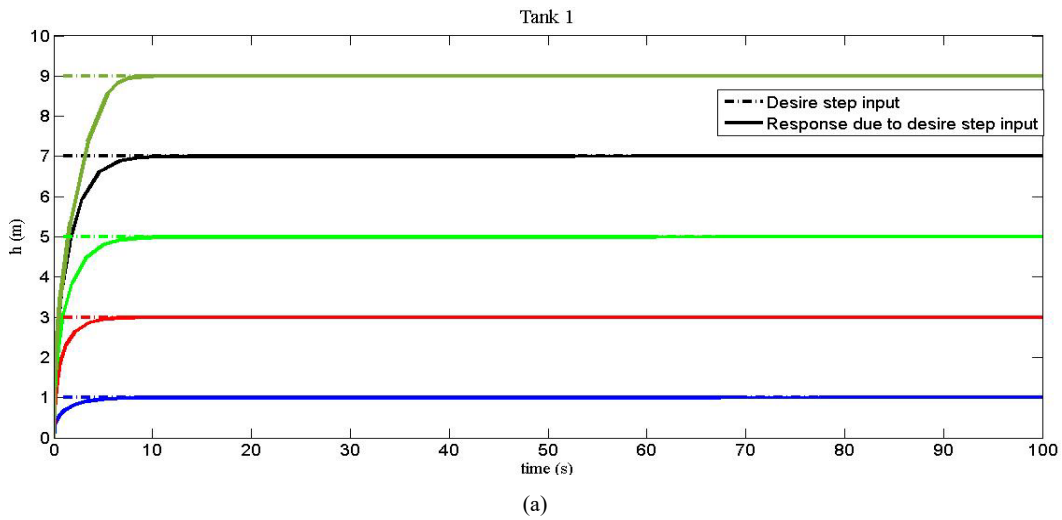

Fig. 7 Block diagram of closed loop control system with p-type ILA



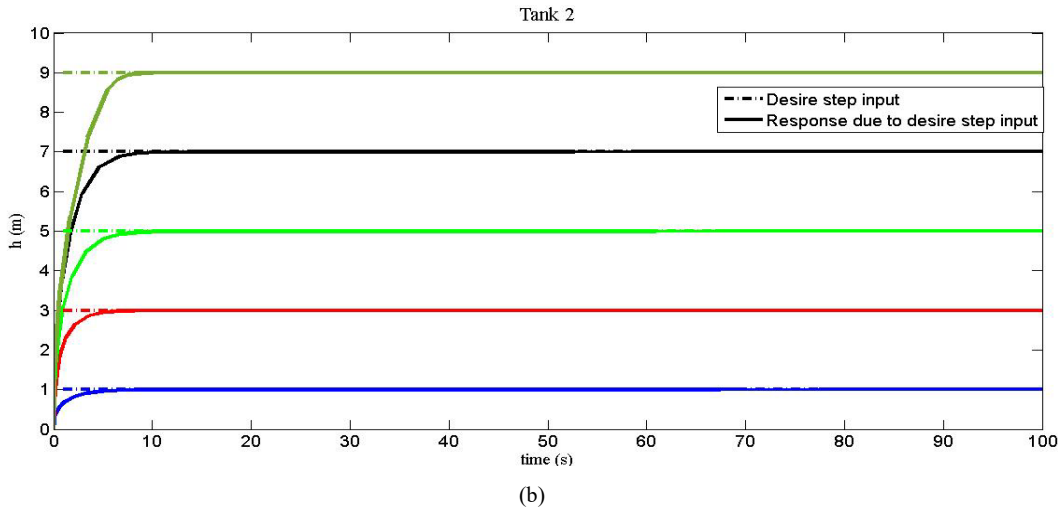

Fig. 8 Responses of ILC to different step inputs (a)Tank 1 (b) Tank 2

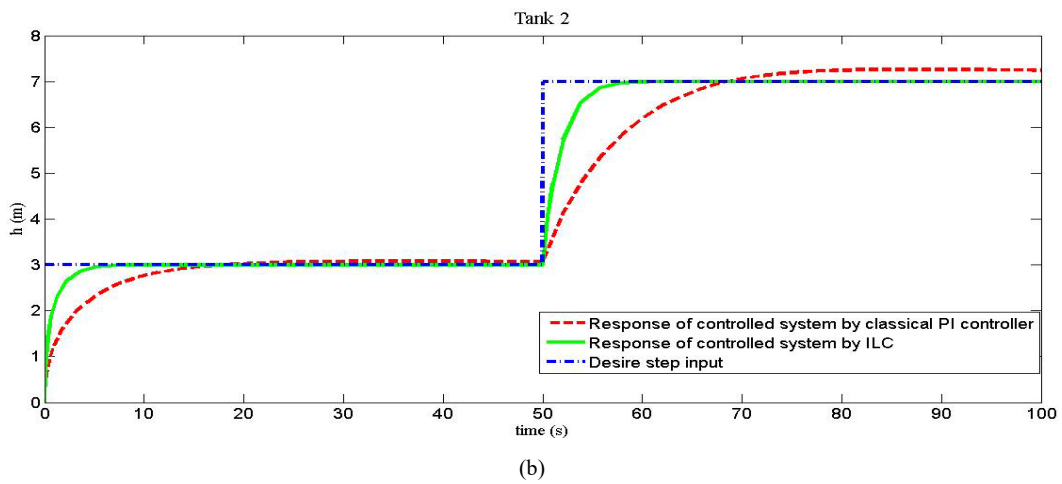
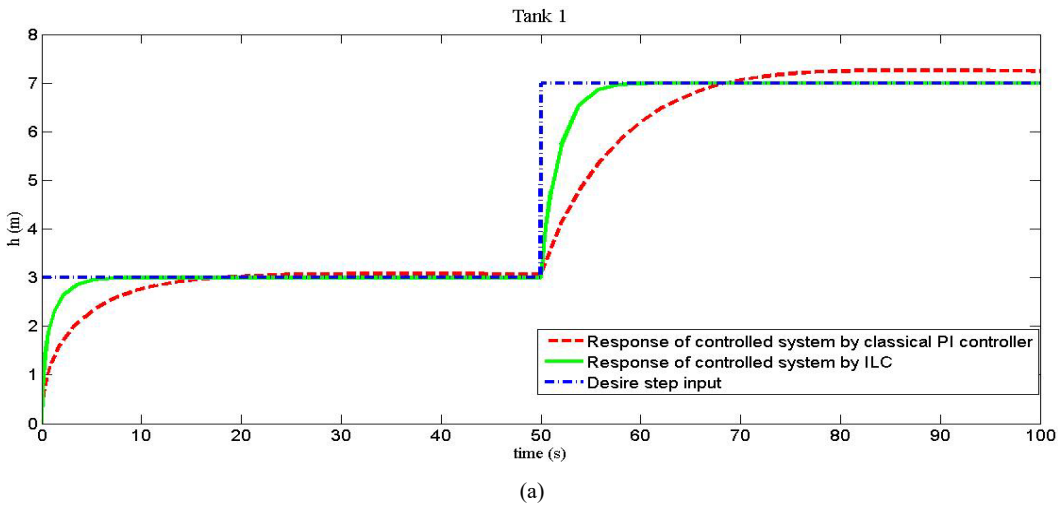

Fig. 9 Comparative results of the ILC and the conventional PI controller in servo mode

### B. Simulation Results of ILC in Servo Mode

In the servo mode, the set-point value is variable. In this section, the simulation results were obtained taking into account the variations of the set-point value. Thus, capability of ILA to follow a reference trajectory was simulated as shown in Fig. 9. Based on the extracted results of ILA controller and by comparing its results to those of the classical PI controller, it was found that the proposed ILC was not sensitive to variations of the reference input as it was demonstrated in Fig. 9.

## VI. CONCLUSION

In this paper, a non-interacting spherical two-tank system was considered as a nonlinear plant to study the capability of an iterative learning controller to compensate the system nonlinearity. This control scheme was found to be an efficient control strategy for controlling such a highly nonlinear dynamic system. Furthermore, it was found that the presented ILA-based controller was superior to the classical PI controller in that it could follow different desired set-points. Consequently, the classical PI controller was not adequate for controlling the highly nonlinear process i.e. the liquid level control in the spherical two-tank process. Next works will be directed towards to the application of other advanced control techniques to control such a highly nonlinear system.

## ACKNOWLEDGMENT

The authors would like to express their gratitude to the *Shiraz University of Technology* (S.U.Tech) for continuous support in the research work.

## REFERENCES

- [1] R. Keerthana, K.S. Gowtham Babu, P. Aravind "Level Control of Nonlinear Tank Process Using Different Control Technique" *International Journal of Advanced Research in Electrical, Electronics and Instrumentation Engineering*, Vol. 3, Issue 9, 2014
- [2] A. R. Tavakolpour-Saleh, H. Jokar, "Adaptive Fuzzy Control of a Nonlinear Tank Process" *International Journal of Mechanical, Aerospace, Industrial, Mechatronic and Manufacturing Engineering* Vol. 10, No. 2, 2016
- [3] X. Trini Xavier, V. Deepika, C. Iswarya, M. Gnana Bringle, H. Kala. "Comparative investigation of diverse controller for a nonlinear level control process" *International Journal of Advanced Research in Electrical, Electronics and Instrumentation Engineering*, Vol. 4, Issue 9, 2015.
- [4] R. Ramya, S. Sakinath Nisa, and P. Aravind. "Modeling and Simulation of Non Linear Tank Using Different Tuning Techniques" *International Journal of Innovative Research and study*. Vol. 3, Issue 2, 2014.
- [5] D. Dinesh Kumar, B. Meenakshipriya, "Design and implementation of non-linear system using gain scheduled PI controller", *Procedia Engineering*, 2012.
- [6] Y. Christy, D. Dinesh Kumar "Modeling and Design of Controllers for Interacting Two Tank Hybrid System (ITTHS)" *International Journal of Engineering and Innovative Technology (IJET)* 3.7, 2014.
- [7] G. Stephanopoulos, *Chemical Process Control*. CA: Prentice Hall of India, New Delhi, 1990, pp. 123–135.
- [8] M. Bristow Tharayil, A. G. Alleyne, "A survey of iterative learning control " *IEEE Control Systems*, vol. 26, no. 3, pp. 96-114, 2006.

**R. Tavakolpour-Saleh** acquired his BSc and MSc degrees from Shiraz University, Iran in 2002 and 2005 respectively and later, his PhD in

Mechanical and Mechatronics Engineering from the Universiti Teknologi Malaysia (UTM) in 2009. Currently, he is an Assistant Professor in the Department of Mechanical and Aerospace Engineering, Shiraz University of Technology, Iran. His current research interests are Mechatronics, Artificial Intelligence, Adaptive and Intelligent Control, Active Vibration/Force Control, Instrumentation and Measurement, Robotics, System Identification, and Energetic Systems.

**A. R. Setoodeh** acquired his BSc, MSc, and PhD degrees in Mechanical Engineering from Shiraz University, Iran. He is currently an Associated Professor in Department of Mechanical and Aerospace Engineering, Shiraz University of Technology, Iran. His current research interests are Composite, Nano Composite, Solid and Nonlinear Mechanics.

**E. Ansari** is a PhD student of Mechanical Engineering in the Department of Mechanical and Aerospace Engineering, Shiraz University of Technology, Iran. His current research interests are Adaptive control system and Fuzzy Logic.