

Design and Implementation of Embedded FM Transmission Control SW for Low Power Battery System

Young-Su Ryu, Kyung-Won Park, Jae-Hoon Song, Ki-Won Kwon

Abstract—In this paper, an embedded frequency modulation (FM) transmission control software (SW) for a low power battery system is designed and implemented. The simultaneous translation systems for various languages are needed as so many international conferences and festivals are held in world wide. Especially in portable transmitting and receiving systems, the ability of long operation life is used for a measure of value. This paper proposes an embedded FM transmission control SW for low power battery system and shows the results of the SW implemented on a portable FM transmission system.

Keywords—FM transmission, simultaneous translation system, portable transmitting and receiving systems, low power embedded control SW.

I. INTRODUCTION

As the globalization age has come, international activities have been held dynamically in world wide such as international symposiums, festivals, and also tour. The environment in various languages causes miscommunication and misunderstanding between people. Especially in the case of activities held outside, only the one leader can hardly lead the crowd. For these reasons, the need of simultaneous translation systems has been increased and also the study and development of portable translation systems have been conducted [1]. However, still there are many problems to be improved.

In most international conferences as illustrated in Fig. 1, English is chosen basically. However, those conferences are for sharing some information and thought so that the simultaneous translation systems are needed. As the simultaneous translation systems were developed and implemented in international conferences, conventions, exhibitions and events, the implemented systems are not compatible for mobility and long time usage with one battery. Especially for outside tour, the specialized tour guide leads the tourists with a local language. In a big group tour, the tour guide can hardly lead all of them even if the tour guide uses a portable microphone.

To solve those problems, many companies have been interested in the industry of meeting, incentives, convention and exhibition (MICE) and the MICE has grown rapidly [2], [3]. The portable translation systems for MICE should provide

Young-Su Ryu and Kyung-Won Park are with Korea Electronics Technology Institute, Seoul, South Korea.

Ki-Won Kwon is with Korea Electronics Technology Institute, Seoul, South Korea (corresponding author, phone: +82-2-6388-6614; fax: +82-2-6388-6679; e-mail: kwonkw@keti.re.kr)

Jae-Hoon Song is with Flexink, Jeju, South Korea (e-mail: song@flexink.co.kr).



Fig. 1 International conference

mobility and long life time [4]. In this paper, an embedded FM transmission control SW for low power battery system is designed and implemented. The design of portable FM transmission platform provides mobility to a speaker and the design of embedded FM transmission control SW provides long life time to the portable FM transmission platform. The results of the SW implemented on a portable FM transmission system are shown as the systems were used on an international festival.

II. DESIGN

This section shows the design of portable FM transmission platform and embedded FM transmission Control SW. For providing mobility, The design of portable FM transmission platform consists of that of case and embedded board. The design of embedded FM transmission control SW consists of the structure of FM transmission firmware stack and control SW for providing long life time. Fig. 2 shows the structure of portable FM transmission system.

A. Design of Portable FM Transmission Platform

1) *Case for Portable FM Transmission:* It is important for a speaker that the case of portable FM transmission is fittable for human body and easy operating with one hand. A power button, a liquid crystal display (LCD), and a control button are well located to use the portable FM transmission system with one hand easily. Also, the location of battery is very important due to its heating reaction and wireless charging system. Fig. 3 shows the design of a case for portable FM transmission.

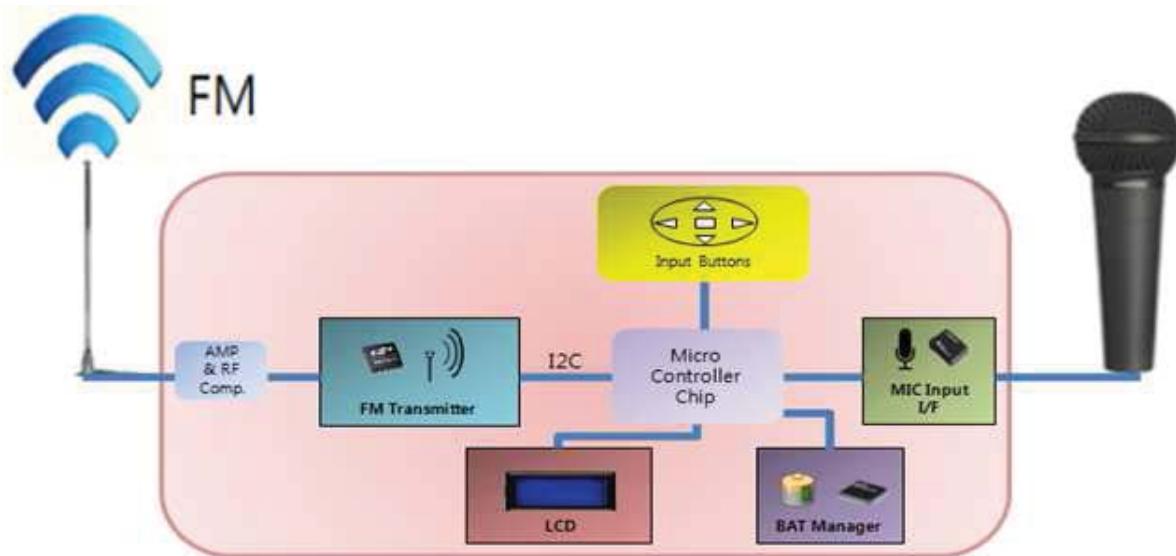

Fig. 2 Structure of portable FM transmission system

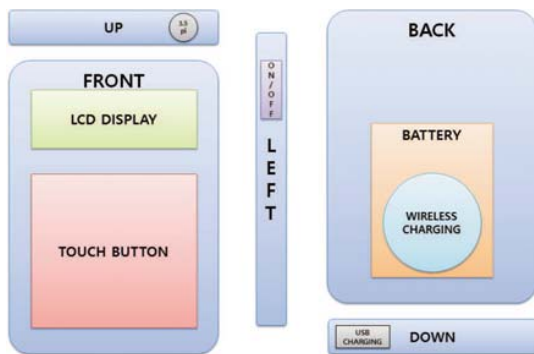

Fig. 3 Design of a case for portable FM transmission

2) *Embedded Board for Portable FM Transmission:* It must be considered to an embedded board for portable FM transmission that the location and distance of transmission antenna, many system on chip (SoC) elements, and system wires to prevent any interference. Fig. 4 shows the design of an embedded board for portable FM transmission.

B. Design of Embedded FM Transmission Control SW

1) *Structure of FM Transmission Firmware Stack:* FM transmission system consists of two parts mainly. One is the device hard ware (HW) and the other is FM transmission HW. The event from device HW such as touch buttons or microphone input is occurred, the FM transmission controller indicate orders to the FM transmission HW. Fig. 5 shows the structure of FM transmission firmware stack.

2) *Structure of Embedded FM Transmission Control SW:* Embedded FM transmission controller conducts to indicate orders which are to tune channels, receive the input signal from microphone, amplify the signal, transmit the signal, and display the status of the system. In sending FM signal, FM transmission controller goes into low power mode which

constrains operating with essential few functions [5]. It detects any external event from the device HW in every 100 ms, and in other time, goes into sleep mode. Fig. 6 shows the structure of embedded FM transmission control SW.

III. IMPLEMENTATION RESULTS

This section shows the implementation results of the portable FM transmission platform and the embedded FM transmission Control SW. In addition, the field test at the international winter festival in Hwa-cheon, Rep. of Korea.

A. Implementation of Portable FM Transmission Platform

The case color of portable FM transmission is designed as black and red. Fig. 7 shows the case of portable FM transmission platform.

The platform consists of a power button, touch buttons, LCD, 3.5pi microphone input, micro-USB charging port, and wireless charging system. Fig. 8 shows the implementation result of portable FM transmission platform.

B. Implementation of Embedded FM Transmission Control SW

The portable FM transmission system with implemented embedded FM transmission control SW provides operation life over 10 hours in continuous operating time. The average transmission power is $-30 \sim -40$ dBm nearby a receiver. Fig. 9 shows the implementation result of embedded FM transmission control SW.

C. Field Test Results

The field test was conducted at the international winter festival in Hwa-cheon, Rep. of Korea. The environment of field test consisted of one spectrum analyzer, one portable FM transmission system, one fixed common FM transmitter,

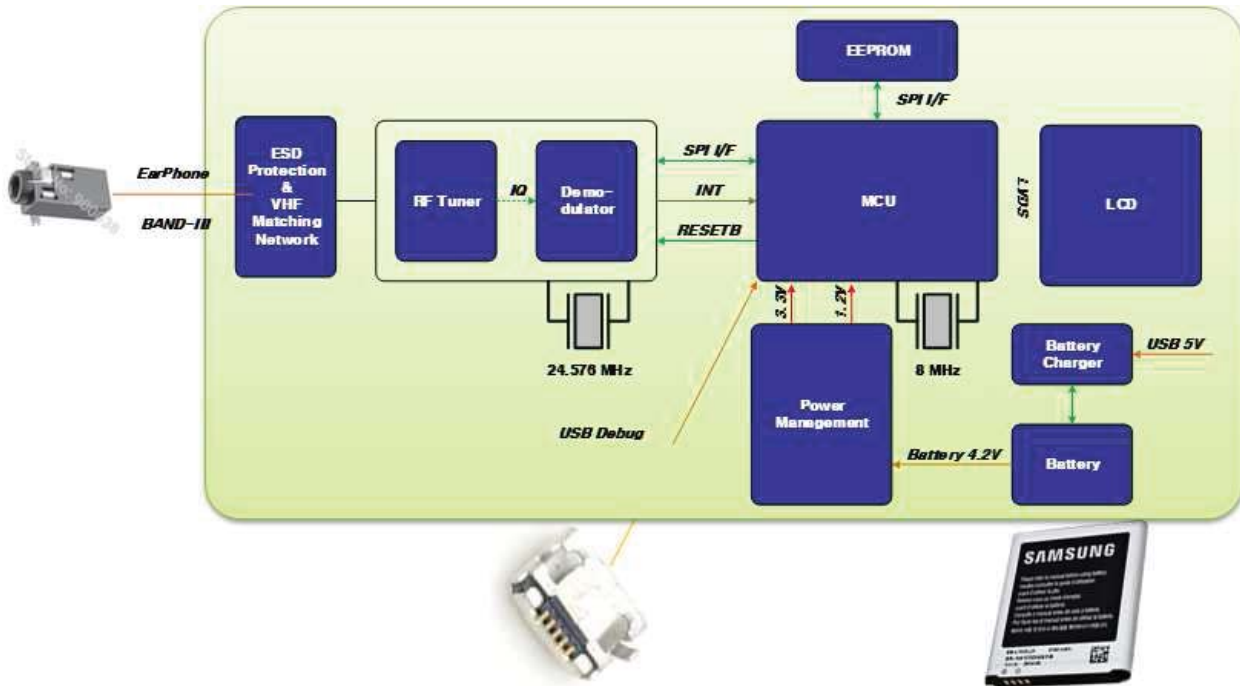

Fig. 4 Design of an embedded board for portable FM transmission

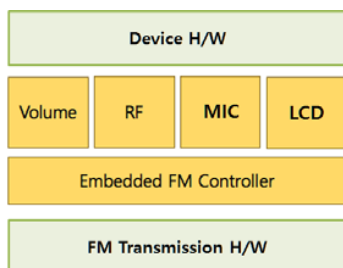

Fig. 5 Structure of FM transmission firmware stack

one movable common FM transmitter, and one common FM receiver. Fig. 10 shows spectrum analyzer and fixed common FM transmitter.

When the transmission power goes under -80 dBm, the received sound can be hardly understood. Table I shows the maximum distance to understand the voice.

TABLE I
RESULTS OF FIELD TEST

	Spectrum Analyzer	Common Receiver
Portable FM	18 m	10 m
Movable Common FM	100 m	80 m
Fixed Common FM	-	200 m

IV. CONCLUSION

In this paper, the design of an embedded FM transmission control SW for low power battery system is proposed and implemented. The implementation results show that as the transmission power of the portable FM transmission system

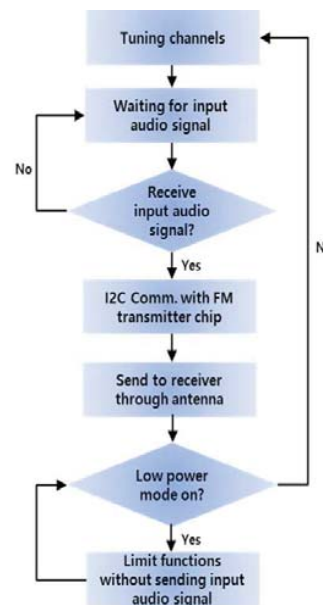

Fig. 6 Structure of embedded FM transmission control SW

is too low, the field test results show the maximum distance of portable FM transmission system to understand the voice is shorter than movable common FM transmission system. It is expected that to attach some amplifier on the board makes the maximum distance of portable FM transmission system to understand the voice further than not attached one. Also, this paper would contribute to enhanced MICE industry with mobility and long life time of FM transmission system.



Fig. 7 Case of portable FM transmission platform



Fig. 8 Implementation result of portable FM transmission platform



Fig. 9 Implementation result of embedded FM transmission control SW



Fig. 10 Spectrum analyzer (left) and fixed common Fm transmitter (right)

ACKNOWLEDGMENT

This research was supported by the Ministry of Trade, Industry & Energy (MOTIE), Korea Institute for Advancement of Technology (KIAT) through the Encouragement Program for The Industries of Economic Cooperation Region [R0004028, A development of simultaneous interpretation streaming and broadcast reception chip embedded earphone for large scale conference].

REFERENCES

- [1] J. G. Oh, J. H. Song, and K. W. Kwon, *A Study of a FM Simultaneous Interpretation Earphone Receiver SW connected with a Smart Device*, Korean Institute of Communications and Information Sciences, 2016.
- [2] J. H. Hong, *A Study on the Potentiality and Competitiveness as an International MICE Tourism Destination*, Academic Society of Event & Convention, 2008.
- [3] M. A. Khan, *MICE Tourism*, International Journal of Multidisciplinary Research and Development, Vol. 2, No. 4, 2015.
- [4] H. Y. Kwon, J. H. Song, M. G. Kang, and K. W. Kwon, *A Design of Embedded Control SW of a Portable FM Transmitter System based a Low Power Battery Management System*, International Conference on Internet (ICONI), 2016.
- [5] J. Segawa, Y. Shirota, K. Fujisaki, T. Kimura, and T. Kanai, *Aggressive Use of Deep Sleep Mode in Low Power Embedded Systems*, IEEE COOL Chips XVII, 2014.

Young-Su Ryu received the B.S. degree in Information & Communication Engineering, Sejong University, Seoul, Korea, in 2015. He has been an assistant researcher in Korea Electronics Technology Institute (KETI), Korea, since 2014. His research interests are digital broadcasting, energy storage system, and cooperative communication.



Kyung-Won Park received the B.S. and M.S. degrees in electrical engineering from Chung-Ang University, Seoul, Korea, in 1999 and 2001, respectively, and Ph.D. degrees in the school of electrical and electronic Engineering from Chung-Ang University in 2005. Since 2005, he has been working at Korea Electronics Technology Institute (KETI), Seongnam-si, Gyeonggi-do, Korea, where he is presently the managerial researcher of Smart Network Research Center. His research interests are in the areas of wireless/wired communications system design and multiple antenna systems including multiple-input multiple-output systems and smart antenna systems.

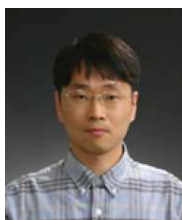

Jae-Hoon Song received Ph. D. candidate in computer engineering from Jeju University, Jeju, Korea, in 2012. Since 2010, he founded his own company to continue work on broadcasting and communications convergence. His research interests are digital broadcasting and cooperative communication.





Ki-Won Kwon received B.S. and M.S. degrees in computer engineering from Kwangwoon University, Korea, in 1997 and 1999. He also received the Ph.D. degree in the School of Electrical & Electronics Engineering from Chung-Ang University, Korea, in 2011. In 1999, he joined in KETI, Korea, where he is presently a managerial researcher at the Smart Network Research Center. His research interests are in the area of advanced broadcasting/communication system and energy convergence networks.