

Determination of the Optimal DG PV Interconnection Location Using Losses and Voltage Regulation as Assessment Indicators Case Study: ECG 33 kV Sub-Transmission Network

Ekow A. Kwofie, Emmanuel K. Anto, Godfred Mensah

Abstract—In this paper, CYME Distribution software has been used to assess the impacts of solar Photovoltaic (PV) distributed generation (DG) plant on the Electricity Company of Ghana (ECG) 33 kV sub-transmission network at different PV penetration levels. As ECG begins to encourage DG PV interconnections within its network, there has been the need to assess the impacts on the sub-transmission losses and voltage contribution. In Tema, a city in Accra - Ghana, ECG has a 33 kV sub-transmission network made up of 20 No. 33 kV buses that was modeled. Three different locations were chosen: The source bus, a bus along the sub-transmission radial network and a bus at the tail end to determine the optimal location for DG PV interconnection. The optimal location was determined based on sub-transmission technical losses and voltage impact. PV capacities at different penetration levels were modeled at each location and simulations performed to determine the optimal PV penetration level. Interconnection at a bus along (or in the middle of) the sub-transmission network offered the highest benefits at an optimal PV penetration level of 80%. At that location, the maximum voltage improvement of 0.789% on the neighboring 33 kV buses and maximum loss reduction of 6.033% over the base case scenario were recorded. Hence, the optimal location for DG PV integration within the 33 kV sub-transmission utility network is at a bus along the sub-transmission radial network.

Keywords—Distributed generation photovoltaic, DG PV, optimal location, penetration level, sub-transmission network.

I. INTRODUCTION

FOR the past three years (2012-2014), Ghana has been experiencing significant power crisis. This has been as a result of the electricity generation-demand imbalance, amongst others. Ghana's demand is projected to grow at 10.56% over the next five years between 2014 and 2018 [1].

In the light of the above, Ghana's Ministry of Energy and Petroleum proposed a plan to increase the installed power generation capacity quickly from about 2000 MW to 5000 MW by 2016 and to increase access of electricity from the

current level of 66% to the universal targeted access of 100% by 2020 [2]. To support the above, the ECG, the main distribution utility in Ghana, is encouraging the interconnection of DG sources within its distribution network throughout the country.

On a global level, right up to the mid-1990s, off grid solar PV applications have been principally used in the telecommunication units, remote houses, and rural electricity supply [3]. Since then, the number of grid-connected systems have increased rapidly. Utility scale systems have also been accelerated in recent years and are steadily becoming an important market [3].

As a result, solar PV plants, among the number of various renewable energy sources (RES), are proposed to be connected to the 33 kV sub-transmission network in Ghana. This is expected to change the planning and operational methods of the distribution utility network which traditionally have power flowing from the central generators through the transmission network to consumers.

As PV penetration increases, there is concern that quality standards of power supply to customers will be violated in regards to voltage, power factor and technical losses [4].

There have been various research works to investigate the impact of large scale solar PV and DG interconnection on the utility network at different PV penetration levels.

Sheikhi et al. [5] investigated, through MATLAB simulations, the influence of the penetration levels of DG units on distribution networks using the IEEE 34 node test feeder and IEEE 30 bus test transmission. Single unit DGs were interconnected at several nodes within the network and the total loss contribution summed as a representation of the total network loss. The results showed that, DGs at different penetration level influenced the distribution network loss profile in a U-shape form, with the minimum loss occurring at a penetration level of 6.8%. Though the study emphasized the importance of DG location and its impact on technical losses at different locations, it did not indicate technical losses impact when the DG is interconnected at the source network bus. Neither did the study indicate the optimal location which resulted in better loss reduction after DG interconnection.

A similar study was performed by Lucian et al. [6], to determine the effects of DG on the electric power systems. A load flow analysis was performed on the IEEE 14 bus system with and without a DG using the NEPLAN software. From the

Ekow Appiah Kwofie and is with the Electricity Company of Ghana, System Planning Division, Box AN 5278, Accra – North, Ghana (phone: +233554215100; e-mail: eappkwofie@gmail.com).

Emmanuel Kwaku Anto is with the Kwame Nkrumah University of Science and Technology, Department of Electrical/Electronic Engineering, PMB, University Post Office, KNUST - Kumasi, Ghana (phone: +233208201565; e-mail: kwakuantoh@yahoo.com).

Godfred Mensah is with the Electricity Company of Ghana, System Planning Division, Box AN 5278, Accra – North, Ghana (phone: +233244765788; e-mail: godmens@ieec.org).

load flow analysis, network technical losses reduced from 13.59 MW to 12.93 MW after the interconnection of the DG. The study indicated that technical losses change as a function of generation levels and loading levels in the network. The study did not emphasize the dependent relationship between the DG location and DG impact on network technical losses after interconnection to the utility network.

Song et al. [8] studied the impacts of voltage on the distribution network system after the injection of the DG. MATLAB was used to simulate the IEEE 33 bus system. Load node voltage increased as DG penetration levels increase. Optimal penetration level for DG was 40%. Optimal location of DG was in the middle of the feeder. However, the study failed to show the optimal penetration level arising from technical losses impact after DG interconnection. In determining the optimal location, the study determined the optimal penetration level based on voltage impact alone at a specific location and applied it to different locations. However, the optimal penetration level is also dependent on the location as will be shown in this study and not just dependent on voltage as indicated.

This study seeks to show how the optimal PV penetration level will vary for different points (locations) of integration of the DG PV with the utility network. In addition, the study will determine the optimal DG PV location based on both loss reduction and voltage improvement

II. THEORY OF PV PENETRATION LEVEL

According to [7] various definitions can be given to the penetration level. These are the *Distribution system point of view definition* and the *Bulk system point of view definition*.

From the distribution system point of view, PV penetration level can be defined variously as;

$$PV \text{ penetration level} = \frac{PV \text{ capacity}}{\text{Peak load of line section or feeder}} \times 100\% \quad (1)$$

$$PV \text{ penetration level} = \frac{PV \text{ capacity}}{\text{Minimum Load}} \times 100\% \quad (2)$$

$$PV \text{ penetration level} = \frac{PV \text{ capacity}}{\text{Transformer or Station rating}} \times 100\% \quad (3)$$

From the bulk system point of view, PV penetration level can be defined variously as;

$$PV \text{ penetration level} = \frac{\text{Annual PV Energy}}{\text{Annual Load Energy}} \times 100\% \quad (4)$$

$$PV \text{ penetration level} = \frac{PV \text{ capacity}}{\text{Peak Load or Minimum Load}} \times 100\% \quad (5)$$

High PV Penetration level is only a concern when there is a technical risk that system performance and reliability would be objectionable and cost of mitigation or allocation would be unreasonable [7].

There is no absolute technical limits and costs to define high PV penetration. The only challenge is that technical risk may increase. The extent to which PV penetration levels can increase will depend on factors such as [7];

- Feeder characteristics (like impedance and capacity)
- DG location on feeder
- Type of voltage control and protection
- Load characteristics

The degree of DG PV impacts on voltages, technical losses, and power factors at buses of the utility network are closely related to the following [8].

- The penetration level of the DG (PV)
- Position of interconnection of the DG (PV) and
- The DG (PV) power factor.

III. CASE STUDY SYSTEM

The sub-transmission network of the ECG is used as a case study system. It is made of 20 No. 33 kV buses of which 6 No. are directly dedicated to selected industries. The remaining 14 No. 33 kV buses have 2 x 20 / 26 MVA primary transformers that transform the 33 kV to 11 kV. There is currently one DG of 25 MW thermal plant interconnected at the 11 kV bus of one of the 33 kV / 11 kV primary substations. Fig. 1 shows the single line diagram of the existing Tema 33 kV sub-transmission network. The sub-transmission network is radially operated but has normally open loops to enable alternative power supply as and when necessary. In ECG, the tolerable power technical losses for sub-transmission network is 2.25% [9].

IV. METHODOLOGY

The ECG Tema 33 kV sub-transmission network was first modeled by using CYME distribution software.

Simulations were then carried out to determine the impacts on the power system such as;

- Technical losses and
- Voltage Levels

The factors outlined below were then varied as will be explained in the subsequent sections to determine the technical losses, and voltage impacts on the utility network

- Penetration level of DG PV
- Location of DG PV

From the simulations the following were determined;

- Optimal DG PV penetration level at each location and
- Optimal DG PV location

A. Network Modelling

The ECG Tema 33kV sub-transmission network was modeled using Cymdist software Fig. 2 shows the Cymdist model of the ECG 33 kV sub-transmission network.

The following considerations were made for the load flow study.

- Constant power load model was used to represent average behavior of the load type in the network.
- Based on data from the Tema H bulk supply point (BSP), the average power factor of the BSP of 93% lagging was then considered for all load points.
- The operating voltage of 161 kV was considered for the Tema BSP.
- Bus sectionalizers on 33 kV and 11 kV buses of primary substations were considered tied together respectively.

- The DG PV was simulated with unity power factor.

Table I shows the steady state voltage profiles' operating limits considered for this study at the Point of Common Coupling (PCC) [10]. Table II shows the permissible loading limit under both normal and emergency conditions for the medium voltage electrical equipment [11].

TABLE I
PERMISSIBLE STEADY STATE VOLTAGE LIMITS AT PCC

Voltage Range (%)	Disconnection Time (s)
<50	0.10 (abnormal)
$50 \leq V < 88$	2.00 (abnormal)
$88 \leq V \leq 110$	Steady state
$110 < V < 137$	2.00 (abnormal)
$137 \leq$	0.33 (abnormal)

TABLE II
PERMISSIBLE LOADING LIMITS UNDER NORMAL AND EMERGENCY (N-1) CONDITIONS

Electrical Equipment	Steady State (%)	Emergency state (%) (N – 1 contingency)
Transformers	70	120
Overhead lines	70	120
Underground cables	70	100

1) Selection of DG Interconnection Location

The solar PV plant was modeled and interconnected at three different locations based on potential interconnections with the Tema 33 kV network. The locations selected are;

- Interconnection at the source bus – Tema BSP 33 kV bus
- Interconnection between the source and tail end of the sub-transmission radial network – Community_25 33 kV bus
- Interconnection at the tail end of the feeder of the sub-transmission radial network – Mbole 33 kV bus.

The locations were selected to determine DG PV impacts on technical losses, voltage, and feeder capacity at different interconnection locations. Fig. 3 shows the three DG PV interconnection selected for the Tema 33 kV sub-transmission network.

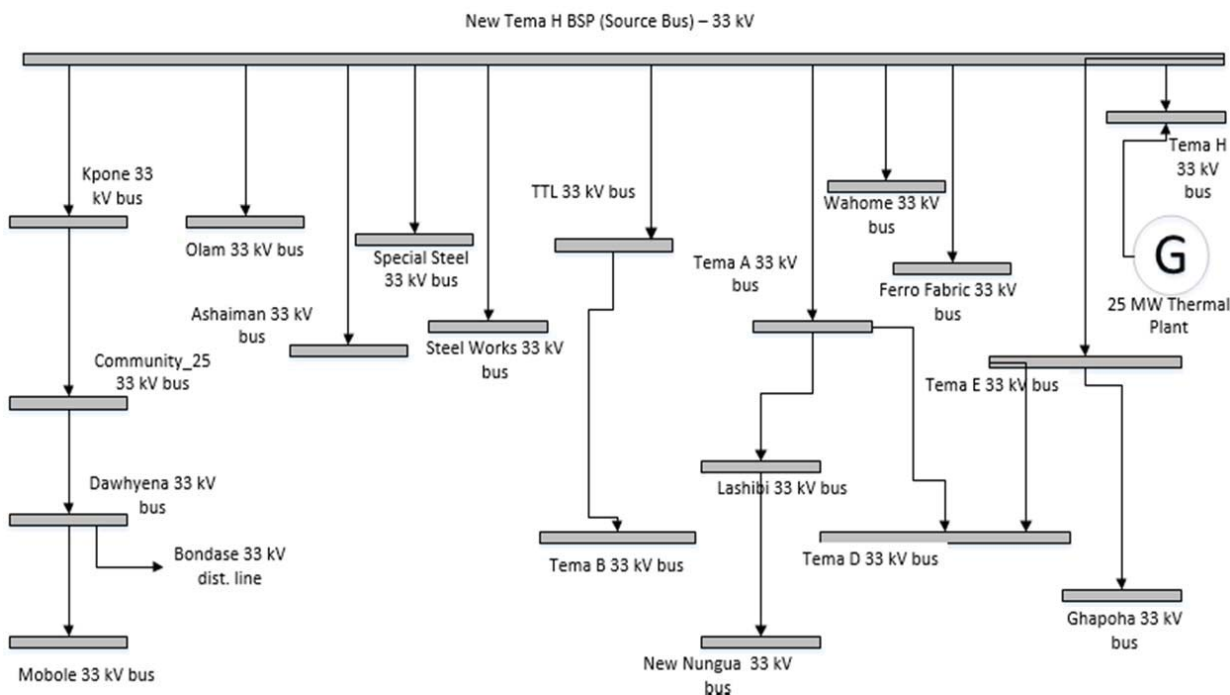

Fig. 1 Single Line Diagram of the Tema 33 kV sub-transmission network

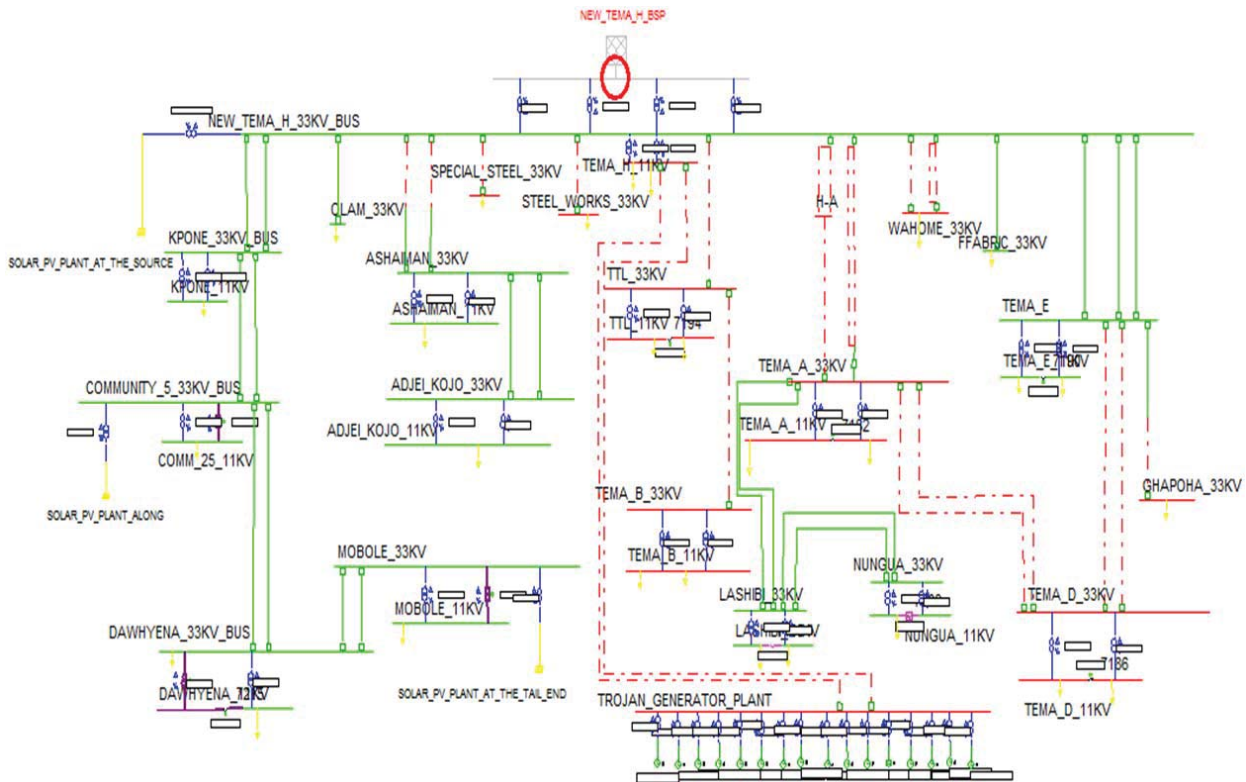

Fig. 2 Cyme model of the ECG Tema 33 kV sub-transmission network

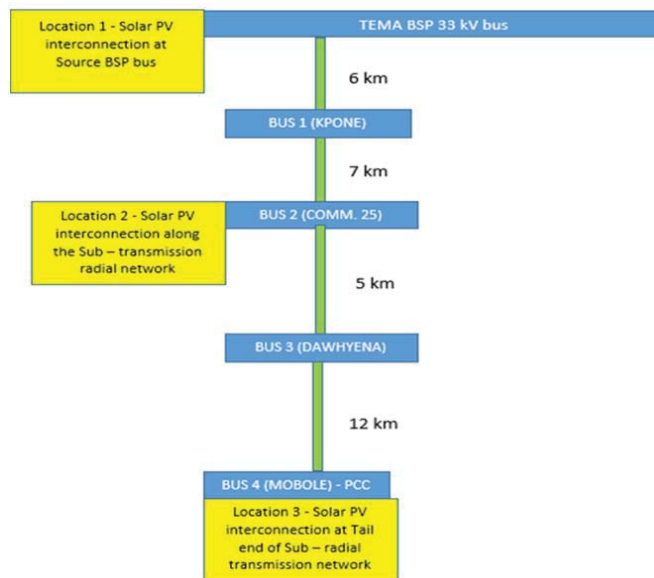

Fig. 3 Solar PV interconnections at the three (3 No.) different locations in the sub-transmission case study network

B. Determination of Optimal DG PV penetration Level

Different DG PV penetration levels are expected to impact differently on the technical losses and voltages in the network. The extent of DG PV penetration level will depend on constraints imposed by the network such as the transfer

capability of the feeder [8] and up-stream transformer capacity.

- A 10% DG penetration was originally started and increased in steps of 10% at the three different locations – at the source, in the middle and at the tail end.
- For DG PV interconnection at the source, the limiting

factor for the extent of DG penetration level was the need to avoid any back feed of power from the power distribution network into the transmission network. According to ECG, power injected into the transmission network by the distribution utility will not currently be paid for by the wholesale operator since there are no approved tariffs by the Ghana's Public Utility Regulatory Commission (PURC) for such scenarios.

- For DG PV interconnection along the sub-transmission radial network, the limiting factor for the extent of DG PV penetration level was the need to avoid overloading at 120% allowable loading limit of the interconnected overhead lines [11] only under single (N-1) contingency.
- For DG PV interconnection at the tail end of the sub-transmission radial network, the limiting factor for the extent of DG PV penetration level was the need to avoid overloading at 120% allowable loading limit of the interconnected overhead lines [11] only under N-1 contingency.
- For DG PV interconnection at the source, the total load on the network used was 260.86 MW, 93% power factor lagging. The penetration level for DG interconnection at the source was calculated in line with (5).
- For DG PV interconnection along the sub-transmission radial network as shown in Fig. 3, the total load on the sub-transmission radial network (i.e. sum of spot loads on the Kpone, Community 25, Dawhyena and Mobole 33 kV buses) used was 22.26 MW, 93% power factor lagging. The penetration level for DG PV interconnection along the sub-transmission radial network was calculated in line with (1)
- For DG PV interconnection at the tail end of the sub-transmission radial network, the total load on the sub-transmission radial network used was 22.26 MW, 93.0% power factor lagging. The penetration level for DG PV interconnection at the tail end of the sub-transmission radial network was calculated in line with (1).
- The optimal PV penetration level was determined based on the following criteria;
 - i. The penetration level at which the sub-transmission technical losses reduction is maximum after DG PV interconnection without violating voltage limits.
 - ii. Where technical losses increase after DG PV interconnection, the penetration level at which the DG PV has the maximum voltage improvement on the network without violating overvoltage limits as indicated in Table I.

C. Determination of Optimal DG PV Interconnection Location

The procedure below was applied to determine the optimal PV location;

- The optimal DG PV penetration level when the solar PV is operated at unity power factor was first determined from the load flow study.
- Comparison of voltage improvement at the optimal PV penetration level on the sub-transmission radial network

(Tema BSP 33 kV bus – Kpone – Community 25 – Dawhyena – Mobole) as shown in Fig. 3 for the respective DG PV interconnection locations.

- Comparison of technical loss reduction at the optimal PV penetration level for the sub-transmission network at the respective locations.
- The optimal location is the location where DG PV interconnection results in the maximum loss reduction in the sub-transmission network and average maximum voltage improvement at the node buses without violating the allowable voltage limits.

V. RESULTS

A. Base Case Results before Utility Scale Solar PV Integration at the Respective Locations

Table III shows the base case (reference) results for technical losses and voltage impact before the interconnection of the utility scale solar PV plant at the respective locations. The locations are at the source, along the sub-transmission radial network and the tail end of the sub-transmission radial network.

TABLE III
BASE CASE (REFERENCE)

Location	Source	Middle	Tail end
Point of analysis	BSP (PCC)	PCC	PCC
Voltage (kV)	31.62	30.868	30.529
Sub-transmission Power loss (MW)	2.879	2.879	2.879
Sub-transmission Power Technical losses (%)	1.104	1.104	1.104

PCC – Point of Common Coupling

B. Results of Impact Studies When the Solar PV Plant Is Interconnected at the Source BSP 33 kV Bus

1) Impact on Voltage at the BSP When Solar PV Plant Is Interconnected at the BSP

The voltage levels recorded at the BSP for penetration levels from 10% to 90% when the DG PV is interconnected at the BSP bus are shown in Table IV and Fig. 4. Fig. 4 is a graphical representation of Table IV.

TABLE IV
RECORDED VOLTAGE LEVELS WHEN SOLAR PV PLANT IS INTERCONNECTED AT THE BSP

Penetration level (%)	BSP Voltage (kV)
0.0	31.620
10.0	31.622
20.0	31.654
30.0	31.694
40.0	31.720
50.0	31.714
60.0	31.711
70.0	31.712
80.0	31.724
90.0	31.729

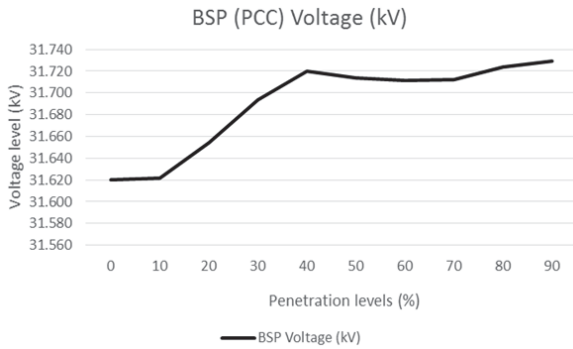

Fig. 4 Impact on Voltage at the BSP when the Solar PV plant is interconnected at the BSP

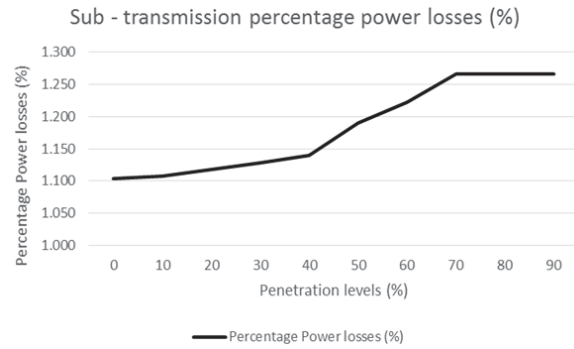

Fig. 5 Impact on sub-transmission technical losses when the Solar PV plant is interconnected at the BSP

1. The 0% penetration level refers to the network performance when there was no PV interconnection.
2. According to Fig. 4, from 0-10% PV penetration level, voltage levels were fairly constant. From 10%-40%, there was a sharp rise from about 31.622 kV to 31.720 kV. This fairly remains constant up to 70% penetration level and gently rises to 31.729 kV when DG PV was at 90% penetration level.
3. Even though dramatic changes are seen in the voltage levels as PV penetration increases, 90% where the highest voltage impact was recorded represents only 0.34% voltage improvement (value of 31.729 kV) over the base case scenario at the BSP (PCC) 33 kV bus.
4. The study has revealed that when DG PV is operated at unity power factor there is only a *marginal contribution* to voltage support at the PCC.

2) Impact on Sub-Transmission Technical Losses When Solar PV Plant Is Interconnected at the BSP

The power technical losses recorded for the sub-transmission network for penetration levels from 10% to 90% when the DG PV is interconnected at the BSP bus is as shown in Table V and Fig. 5. Fig. 5 is a graphical representation of Table V.

TABLE V
RECORDED SUB-TRANSMISSION TECHNICAL LOSSES WHEN SOLAR PV PLANT IS INTERCONNECTED AT THE BSP

Penetration level (%)	Sub-transmission technical losses (MW)	Percentage Power technical losses pf (%)
0.00	2.879	1.104
10.00	2.890	1.108
20.00	2.915	1.118
30.00	2.943	1.128
40.00	2.973	1.140
50.00	3.106	1.191
60.00	3.189	1.222
70.00	3.303	1.266
80.00	3.302	1.266
90.00	3.302	1.266

1. The 0% penetration level refers to the network performance when there was no PV interconnection.
2. From Fig. 5, when solar PV plant is interconnected at the BSP, as PV penetration increases, sub-transmission technical losses generally increase.
3. This is because as PV penetration increases, active power flow into the network increases. At the source, lagging power factor initially degrades as PV penetration increases. This explains the gentle rise in technical losses till 70% DG penetration. From 70% DG penetration, leading power factor at the 33 kV BSP bus increases; thus technical losses remain fairly constant till 90% DG penetration.
4. The study has revealed that when solar PV plant is interconnected to the utility network, it does not necessarily result in a reduction in utility technical losses as stated in [4]. Its impact on technical loss reduction is very much dependent on the location of interconnection of the DG PV.

3) Optimal PV Penetration Level When Solar PV Plant Is Interconnected at the BSP

From above, the maximum voltage impact was at 90% DG penetration level and technical losses recorded were also within the allowable limit of 2.25% [9]. Based on this the optimal DG penetration level for interconnection at the source bus in the Tema network is 90%. Table VI shows the technical losses and voltages at 90% PV penetration level.

TABLE VI
VOLTAGE AND PEAK TECHNICAL LOSSES AT 90% PV PENETRATION LEVEL

Power Factor at which the Solar PV was operated (%)	Operating Voltage (kV)	Percentage peak technical losses (%)
100	31.729	1.27

- The 90% DG penetration level recorded voltage improvement of 0.34% (31.729 kV) which was the maximum voltage impact recorded over the base case scenario at the BSP (PCC) 33 kV bus for the different DG penetration levels.
- Percentage peak technical losses was less than allowable limit of 2.25% [9].
- From Fig. 5, at the BSP, when DG PV is interconnected,

technical losses increase as PV penetration level increases. However, the highest voltage contribution as shown in Table IV is recorded at 90% PV penetration level. Thus the optimal PV penetration level based on voltage impact when the DG PV is interconnected at the source bus is 90%.

C. Results of Impact Studies When the Solar PV Plant Is Interconnected at a Bus along the Sub-Transmission Radial Network

1) Impact on the Voltages at the PCC When the Solar PV Plant Is Interconnected along the Sub-Transmission Radial Network

The voltage levels recorded at the PCC for penetration levels from 10% to 330% when the DG PV is interconnected along the sub-transmission radial network is as shown in Table VII and Fig. 6. Fig. 6 is a graphical representation of Table VII.

TABLE VII
PCC VOLTAGE WHEN THE SOLAR PV PLANT IS INTERCONNECTED ALONG THE SUB-TRANSMISSION RADIAL NETWORK

Penetration level (%)	PCC Voltage (kV)
0.00	30.868
10.00	30.913
20.00	30.932
30.00	30.995
40.00	31.039
50.00	31.080
60.00	31.117
70.00	31.157
80.00	31.215
90.00	31.247
100.00	31.284
110.00	31.306
120.00	31.342
130.00	31.340
140.00	31.375
150.00	31.410
160.00	31.443
170.00	31.476
180.00	31.488
190.00	31.499
200.00	31.531
210.00	31.561
220.00	31.591
230.00	31.620
240.00	31.662
250.00	31.675
260.00	31.697
270.00	31.722
280.00	31.747
290.00	31.777
300.00	31.800
310.00	31.822
320.00	31.843
330.00	31.864

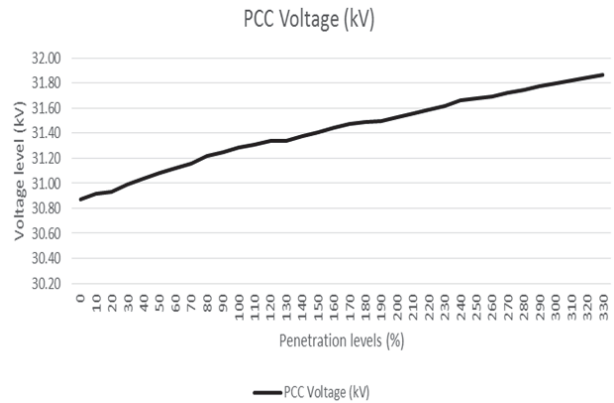

Fig. 6 Voltages at the PCC when the Solar PV plant is interconnected along the sub-transmission radial network

1. The 0% penetration level refers to the network performance when there was no PV interconnection.
2. From Fig. 6, when the solar PV plant is interconnected along the sub-transmission radial network closer to the load bus, as PV penetration increases, the voltages recorded at the PCC increase [8].
3. At a penetration level of 320% which represents a capacity of 72 MWp, the voltage improvement at the PCC with respect to the base case analysis was 3.23% which is higher than 0.34% when DG PV was interconnected at the source at 90% penetration level representing a capacity of 209.77 MWp. The higher voltage improvement is as a result of reduction in technical losses of associated interconnected feeders to the load bus when the DG PV is interconnected at the load bus.
4. When DG PV is interconnected within the network compared to interconnection at the source bus, there is better voltage improvement at the PCC when DG PV is even operated at unity power factor.

2) Impact on the Sub-Transmission Technical Losses When the Solar PV Plant Is Interconnected along the Sub-Transmission Radial Network

The power technical losses recorded for the sub-transmission network for penetration levels from 10% to 330% when the DG PV is interconnected along the sub-transmission radial network is as shown in Table VIII and Fig. 7. Fig. 7 is a graphical representation of Table VIII.

1. The 0% penetration level refers to the network performance when there was no PV interconnection.
2. From Fig. 7, when the solar PV plant is interconnected at a bus along the sub-transmission radial network, as PV penetration increases, sub-transmission follows a U-shape curve [5] and attains a minimum value at 80% PV penetration level when operated at unity power factor.

TABLE VIII
RECORDED SUB-TRANSMISSION TECHNICAL LOSSES WHEN SOLAR PV PLANT IS INTERCONNECTED ALONG THE SUB-TRANSMISSION NETWORKS

Penetration level (%)	Sub-transmission technical losses (MW)	Percentage Sub-transmission technical losses (%)
0.0	2.879	1.104
10.0	2.849	1.092
20.0	2.818	1.080
30.0	2.774	1.063
40.0	2.749	1.054
50.0	2.73	1.046
60.0	2.72	1.043
70.0	2.711	1.039
80.0	2.705	1.037
90.0	2.715	1.041
100.0	2.721	1.043
110.0	2.732	1.047
120.0	2.747	1.053
130.0	2.78	1.066
140.0	2.805	1.075
150.0	2.833	1.086
160.0	2.867	1.099
170.0	2.905	1.114
180.0	2.966	1.137
190.0	3.012	1.155
200.0	3.064	1.174
210.0	3.12	1.196
220.0	3.18	1.219
230.0	3.245	1.244
240.0	3.352	1.285
250.0	3.454	1.324
260.0	3.534	1.355
270.0	3.62	1.388
280.0	3.709	1.422
290.0	3.866	1.482
300.0	3.967	1.521
310.0	4.072	1.561
320.0	4.181	1.603
330.0	4.295	1.647

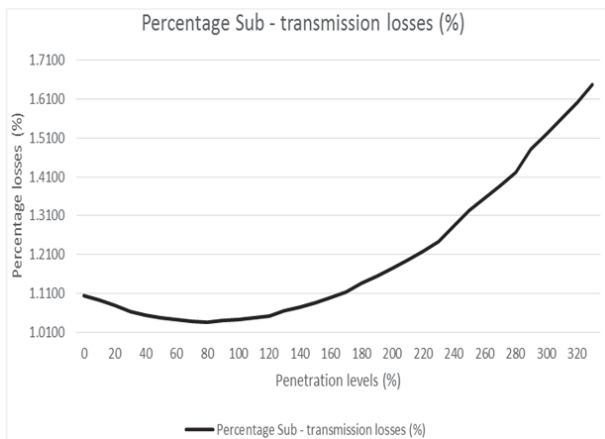

Fig. 7 Recorded sub-transmission technical losses when Solar PV plant is interconnected along the sub-transmission networks

3) Optimal PV Penetration Level When Solar PV Plant Is Interconnected along the Sub-Transmission Network

The optimal PV penetration level for this scenario based on the minimum technical losses recorded is at 80%. Table IX shows the voltage and peak technical losses at 80% DG PV penetration level.

1. Recorded voltages at 80% PV penetration were within allowable limits.
2. Percentage peak loss was less than allowable limit of 2.25% [9].
3. Based on the Tema 33 kV sub-transmission model used for the study, the allowable PV penetration level taking into consideration the maximum technical losses reduction is 80% when the solar PV plant is interconnected along the sub-transmission radial network and operated at unity power factor. At 80% there was a maximum loss reduction of 6.033% and a voltage improvement of 1.124% over the base case scenario at the PCC.

TABLE IX
VOLTAGE, AND PEAK TECHNICAL LOSSES AT 80% PV PENETRATION LEVEL

Power Factor at which the Solar PV was operated (%)	Operating Voltage (kV) PCC (Comm- 25, 33 kV bus)	Percentage peak technical losses (%)
100	31.215	1.037

D. Results of Impact Studies When the Solar PV Plant Is Interconnected at the Tail End of the Sub-Transmission Radial Network (at Mobole 33 kV Bus)

1) Impact on the voltages at the PCC When the Solar PV Plant Is Interconnected at the Tail End of the Feeder

The voltage levels recorded at the PCC (Mobole 33 kV bus) for penetration levels from 10% to 220% when the DG PV operated at unity power factor is interconnected at the tail end of the feeder is as shown in Table X and Fig. 8. Fig. 8 is a graphical representation of Table X.

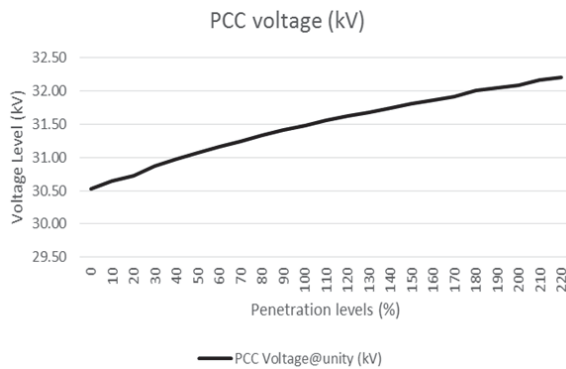

Fig. 8 Voltages at the PCC when the Solar PV plant is interconnected along the sub-transmission radial network

1. The 0% penetration level refers to the network performance when there was no PV interconnection.
2. From Fig. 8, when the solar PV plant is interconnected along the sub-transmission radial network, as PV

penetration increases, the voltages recorded at the PCC also increase.

3. The higher voltage improvement is as a result of reduction in technical losses of associated with interconnected feeders to the load bus when the DG PV is interconnected at the load bus.

TABLE X
PCC VOLTAGE WHEN THE SOLAR PV PLANT IS INTERCONNECTED AT THE TAIL END OF THE SUB-TRANSMISSION RADIAL NETWORK

Penetration level (%)	PCC Voltage (kV)
0.0	30.529
10.0	30.641
20.0	30.723
30.0	30.877
40.0	30.975
50.0	31.069
60.0	31.16
70.0	31.243
80.0	31.332
90.0	31.412
100.0	31.483
110.0	31.558
120.0	31.622
130.0	31.684
140.0	31.747
150.0	31.811
160.0	31.867
170.0	31.919
180.0	32.007
190.0	32.052
200.0	32.093
210.0	32.165
220.0	32.201

2) Impact on the Sub-Transmission Technical Losses When the Solar PV Plant Is Interconnected at the Tail End of the Feeder

The power technical losses recorded for the sub-transmission network for penetration levels from 10% to 220% when the DG PV is interconnected at the tail end of the sub-transmission radial network is as shown in Table XI and Fig. 9.

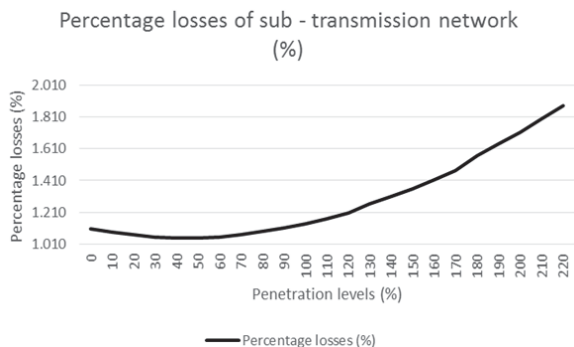

Fig. 9 Recorded sub-transmission technical losses when Solar PV plant is interconnected at the tail end of the sub-transmission radial network

TABLE XI
RECORDED SUB-TRANSMISSION TECHNICAL LOSSES WHEN SOLAR PV PLANT IS INTERCONNECTED AT THE TAIL END OF THE SUB-TRANSMISSION RADIAL NETWORK

Penetration level (%)	Sub-transmission technical losses (MW)	Percentage technical losses (%)
0.0	2.8895	1.11
10.0	2.8317	1.09
20.0	2.7929	1.07
30.0	2.7516	1.06
40.0	2.7402	1.05
50.0	2.7416	1.05
60.0	2.7554	1.06
70.0	2.787	1.07
80.0	2.8437	1.09
90.0	2.8985	1.11
100.0	2.9738	1.14
110.0	3.0524	1.17
120.0	3.1414	1.20
130.0	3.2945	1.26
140.0	3.4135	1.31
150.0	3.5433	1.36
160.0	3.6858	1.41
170.0	3.8405	1.47
180.0	4.0903	1.57
190.0	4.2731	1.64
200.0	4.4678	1.71
210.0	4.6882	1.80
220.0	4.9066	1.88

Fig. 9 is a graphical representation of Table XI.

1. The 0% penetration level refers to the network performance when there was no PV interconnection.
2. From Fig. 9, when the solar PV plant is interconnected at the tail end of the sub-transmission radial network, as PV penetration increases, sub-transmission follows a U-shape curve and attains a minimum value at 40% PV penetration for solar PV plants operated at unity power factor.

3) Optimal PV Penetration Level When Solar PV Plant Is Interconnected at the Tail End of the Sub-Transmission Radial Network

The optimal PV penetration level for this scenario was chosen based on the minimum technical losses recorded. From Table XI, the optimal PV penetration was 40% when the solar PV was operated at unity. Table XII shows the technical losses and voltages at the 40% PV penetration level.

1. Recorded voltages at 40% PV penetration were within allowable limits
2. Percentage peak technical losses were less than allowable limit of 2.25% [9]
3. Based on the Tema 33 kV sub-transmission model used for the study, the allowable PV penetration level taking into consideration only the technical losses are 40% at unity when the solar PV plant is interconnected at the tail end of the feeder.
4. At 40% DG penetration level, the voltage improvement over the base case was 1.461% at the PCC and loss reduction over the base case was 4.891%.

TABLE XII
VOLTAGE AND PEAK TECHNICAL LOSSES AT 40% PV PENETRATION LEVEL

Power Factor at which the Solar PV was operated (%)	Operating Voltage (kV) PCC (Comm- 25, 33 kV bus)	Percentage peak technical losses (%)
100	30.975	1.05

E. Determination of the Optimal PV Location in the ECG Sub-Transmission Network

Fig. 10 shows the percentage voltage contribution on the selected 33 kV buses shown in Fig. 3 after the interconnection of solar PV. At the optimal PV penetration level at unity power factor for the respective interconnection locations.

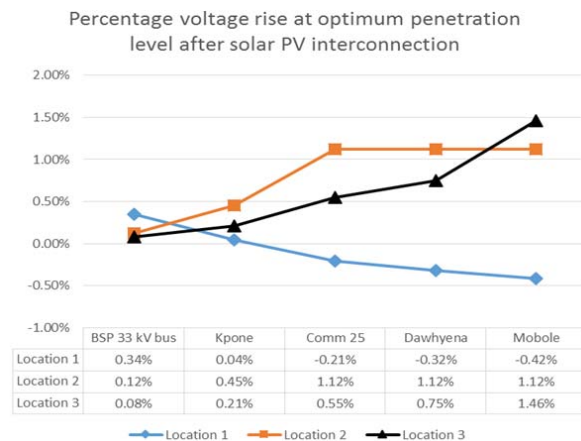

Fig. 10 Percentage voltage contribution at selected 33 kV buses after interconnection of solar PV at the optimal PV penetration level for the respective interconnection locations under consideration

1. Although from Fig. 10, solar PV interconnection at Location 1 for 90% PV penetration level recorded the highest percentage voltage contribution at the Tema BSP 33 kV bus at the downstream buses, a negative voltage impact is recorded.
2. When the solar PV is interconnected at Location 2 for 80% PV penetration level, percentage voltage contribution at Tema BSP, Kpone, Comm 25 and Dawhyena 33 kV buses are higher than the case where solar PV is interconnected at Location 3. However, it records the highest voltage contribution at Kpone, Comm. 25 and Dawhyena 33 kV buses.
3. The highest voltage contribution when solar PV is interconnected at Location 3 for 40% PV penetration level is only recorded at the Mobole 33 kV bus.

Fig. 11 compares the average voltage contribution at the selected 33 kV buses in Fig. 10 and the technical losses recorded in the sub-transmission network when the solar PV plant were interconnected at the respective locations.

1. Interconnection of DG PV at the source bus, recorded an average negative voltage impact on the neighboring 33 kV buses after the interconnection of the optimal 90% DG PV penetration level.
2. Interconnection of DG PV at Location 2 resulted in the

maximum percentage average voltage improvement of 0.789% to the utility network and maximum loss reduction of 6.033% over the base case value.

3. All the technical losses recorded for the respective locations were below the allowable limit of 2.25% for sub-transmission network in ECG.
4. Voltage contribution at the respective buses were all within the allowable limits (0.88 pu to 1.1 pu)
5. Based on Fig. 11, the optimal location at the Optimal PV penetration level at which DG PV is operated is Location 2 i.e. when the solar PV is interconnected along the sub-transmission radial network at Community_25 33 kV bus.

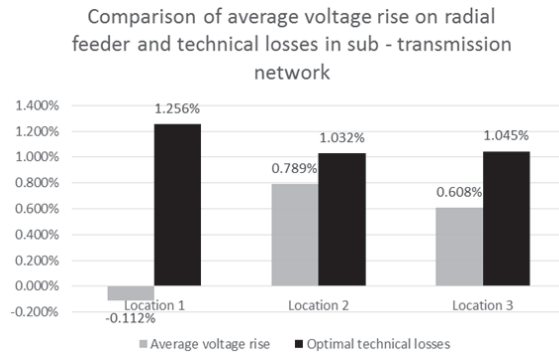

Fig. 11 Comparison of average voltage contribution on the selected 33 kV buses and the technical losses in the sub-transmission network at the respective locations

VI. CONCLUSIONS

The following conclusions are made from the study;

1. The optimal PV penetration levels vary as DG PV location in the utility network and transfer capability of feeders vary.
2. The optimal DG PV penetration level of 90% was recorded at a sub-transmission power loss of 1.27% and an average voltage reduction of 0.112% on the neighboring 33 kV buses when DG PV was interconnected at the source bus.
3. When interconnected at a bus along the sub-transmission radial network, the optimal DG PV penetration level of 80% was recorded at a sub-transmission power loss of 1.032% and an average voltage improvement of 0.789% on the neighboring 33 kV buses.
4. The optimal DG PV penetration level of 40% was recorded at a sub-transmission power loss of 1.045% and an average voltage improvement of 0.608% on the neighboring 33 kV buses when DG PV was interconnected at the tail end bus of the sub-transmission radial network.
5. Interconnection at a bus along the sub-transmission network offered the maximum benefits in terms of voltage improvement and loss reduction hence the preferred optimal location for DG PV integration with the 33 kV sub-transmission utility network is at a bus along the sub-transmission radial network in this case at the Community-25 33 kV bus as shown in Fig. 3.

6. When DG PV are interconnected at the source BSP 33 kV bus of the utility network, technical losses in the sub-transmission network increase.
 7. From the study DG PV only contribute to technical losses reduction within the sub-transmission network when interconnected along the sub-transmission network either at the tail end or in the middle at a defined DG PV penetration level.
- [10] IEEE Standards Coordination Committee 21, "IEEE Application Guide for IEEE Std. 1547™, IEEE Standard for Interconnecting Distributed Resources with Electric Power Systems" IEEE, 3 Park Avenue New York (NY), 15th April 2009
- [11] Ing. Godfred Mensah, "Basic System Planning for ECG Staff.", System Planning Division, Electricity Company of Ghana (ECG), November 2015.

VII. RECOMMENDATIONS

1. ECG currently has 28 BSPs within its network and still counting. With the plans to increase its embedded systems integration, there will be the need for ECG to determine the optimal DG capacity and interconnection locations within each BSP network at the sub-transmission level.
2. When DG locations are constrained by land availability, grid issues arising from grid studies such as potential increase in technical losses should be factored in the Power Purchase Agreements (PPAs) between utilities and Independent Power Producers (IPPs). This is necessary to ensure the necessary mitigating measures are implemented by both parties.
3. In Ghana, there is the potential for more DG integration in the utility network at all voltage levels. Without adequate planning and guidance, there is the likelihood of violating the utility power quality requirements. There is the need therefore for ECG to build the necessary capacity in embedded systems integration especially in areas of embedded systems regulations, planning and operation. And undertake impact studies within the distribution network

REFERENCES

- [1] Ghana Grid Company Limited (GRIDCo), 2014 Electricity Supply Plan: GRIDCo, Tema: 2014.
- [2] Ministry of Energy, Republic of Ghana: National Energy Policy: February, 2010.
- [3] International Renewable Energy Agency (IRENA) Working Paper, "Renewable Energy Technologies: Cost analysis series, Volume 1: Power sector: Issue 4/5, Solar Photovoltaics", June 2012. p.12 – 13.
- [4] S. J. Lewis, "Analysis and Management of the Impacts of a High Penetration of Photovoltaic Systems in an Electricity Distribution Network." *Innovative Smart Grid Technologies Asia (ISGT)*. p.1 – 7, IEEE PES, 2011.
- [5] A. Sheikhi, A. Maani, F. Safe, A. M. Ranjbar, "Distributed Generation Penetration Impact on Distribution Networks Loss" International Conference on Renewable Energies and Power Quality (ICREPQ '13), Spain 20th – 22nd March, 2013.
- [6] Lucian Ioan Dulau, Mihail Abrudaen, Dorin Bica, "Effects of Distributed Generation on Electric Power Systems." The 7th International Conference in Interdisciplinarity in Engineering (INTER – ENG 2013), Pg. 681 – 686, 2013.
- [7] Abraham Ellis, "Grid operations and High penetration PV", Sandia National Laboratories. Utility/Lab workshop on PV Technology and Systems, November 8 – 9, 2010, Tempe, Arizona. Available: http://www1.eere.energy.gov/solar/pdfs/2010ulw_ellis.pdf
- [8] Wei Song, Xinghua Zhou, Xiaolong Liu, Hongting Zhou, "A study on impacts of Distributed Generation voltage in Distribution network system." Asia Pacific Energy Equipment Engineering Research Conference (AP3ER 2015), 2015.
- [9] Global Energy Consulting Engineers India, "National Technical and Commercial Loss Study for ECG & VRA/NEDCo, Ghana" submitted to the Ministry of Energy, Government of Ghana, 2012.