

Wind Fragility of Window Glass in 10-Story Apartment with Two Different Window Models

Viriyavudh Sim, WooYoung Jung

Abstract—Damage due to high wind is not limited to load resistance components such as beam and column. The majority of damage is due to breach in the building envelope such as broken roof, window, and door. In this paper, wind fragility of window glass in residential apartment was determined to compare the difference between two window configuration models. Monte Carlo Simulation method had been used to derive damage data and analytical fragilities were constructed. Fragility of window system showed that window located in leeward wall had higher probability of failure, especially those close to the edge of structure. Between the two window models, Model 2 had higher probability of failure, this was due to the number of panel in this configuration.

Keywords—Wind fragility, glass window, high rise apartment, Monte Carlo Simulation method.

I. INTRODUCTION

RECENT change of global climate results in the increment of typhoon with high wind intensity globally, including South Korea. Billions of dollars were spent for restoration of the damage due to wind and water damage from typhoons [1]. In case of residential structure, properly built structures can withstand this disaster without collapse; however, the majority of damage and consequent insurance losses are the consequence of a breach in the building envelope and broken windows [2]. The failure of these components did not affect overall safety of structural performance; however, it allows the water to penetrate and cause extensive interior damage as well as damage to contents. Increase of population growth results in more residential building in typhoon-prone regions which will result in even greater losses in the future.

In high rise residential building, the windows are usually built with glass and metal frames. The resistance capacity of glass depends on their dimension and thickness [3]. Therefore, different window size configuration could have different probability of failure when subjected to identical load. The assessment of wind fragility is essential to judge the vulnerability of each window model configuration in the apartment building. From fragilities function, it allows the prediction of weakness and expected losses of the structure, thus reasonable protection could be made to ensure the safety of their residents.

Fragility is a probability of exceeding any limit state of a structure, it can be defined as a conditional probability of failure

of a structural member or system in term of wind speed as [4]:

$$P_f(V) = P[D \geq d|V] \quad (1)$$

where D = uncertain damage state of a particular component, in this study, it is window panel, d = a particular value without uncertainty of D , and V = a particular wind speed at which the probability of failure is evaluate. The fragility of a structural system commonly model using a lognormal cumulative distribution function [2], [4]:

$$Fr(V) = \Phi \left[\frac{\ln(V) - \lambda_R}{\xi_R} \right] \quad (2)$$

in which $\Phi(\cdot)$ = standard normal cumulative distribution function, λ_R = logarithmic median of capacity R , and ξ_R = logarithmic standard deviation of capacity R . This fragility model is an important component for development of risk assessment framework that provides the factual basis for hazard mitigation plan [5].

The objective of this study is to compare the wind fragility of window system with two different configuration models. Moreover, this will present the statistical approach to the development of wind fragility. This method uses a Monte Carlo Simulation method that generates wind loads based on statistical data from [6] and resistance capacity of structure from experiment performed by [7]. From this demand and capacity, damage information can be determined.

II. WIND FRAGILITY MODEL FOR INDIVIDUAL WINDOW

A. Window Failure Limit State

Equation (1) shows the failure of window at a particular wind speed V was the exceedance of window capacity from the wind loads. This loads were the combination of internal and external pressures acting on a window panel. When these loads exceed their resistance capacity, the failure of window occurred; failure here refers to the damage to window metal frames or rupture of window glass. The limit state function for one window at any floor level could be written in terms of the basic random variables as:

$$f(V) = R - W \quad (3)$$

V. Sim is Ph.D. student with the Department of Civil Engineering, Gangneung-Wonju National University, South Korea.

WY. Jung, Professor / Ph.D., is with the Department of Civil Engineering, Gangneung-Wonju National University, Gangneung, South Korea (e-mail: woojung@gwnu.ac.kr).

where R = resistance capacity of frames or glass panel, and W = wind loads acting on the window. Window failure can be defined as the condition where $f(V) < 0$. Thus, the probability of failure is a function of the basic wind speed V squared.

B. Baseline Structures Property and Resistance Capacity

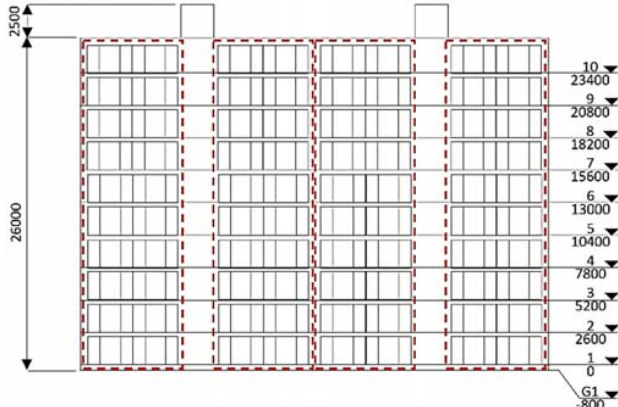

(a) Front view of 4 units based apartment

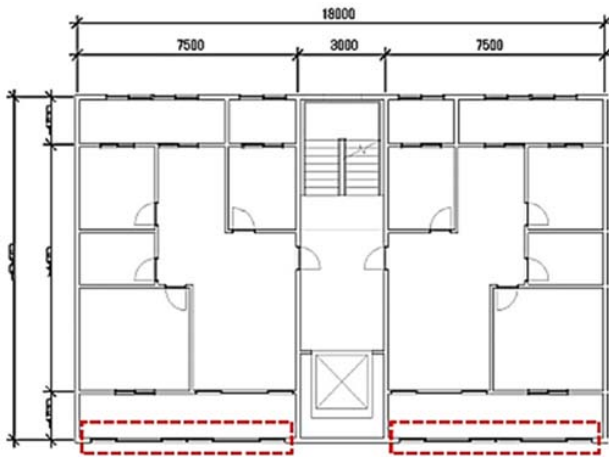

(b) Plan view of 2 units

Fig. 1 Geometries of building and unit (unit: mm) (modified from [7])

A 10 stories apartment with 4 units had been used for this study; geometry of building and each unit were shown in Fig. 1. There are four housing units per floor with two sets of window at the outside balcony. The configuration of these windows was shown in Fig. 2. In Fig. 2 (a), we modeled the whole window as only one panel, which included the center and side glass together as one surface area, thus total windows for one floor is 8 windows. For Fig. 2 (b), we modeled the center and side glass as three separate panels, thus in one floor there are 24 total windows. Dimensions and detailed properties of structures were shown in Table I. Moreover, to calculate resistance capacity (R) of window in (3), statistical resistance capacity of frames and glass were shown in Table II.

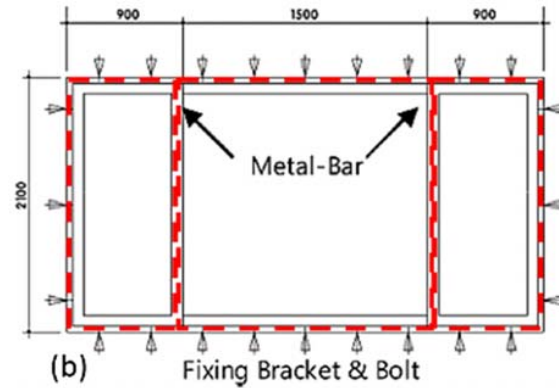
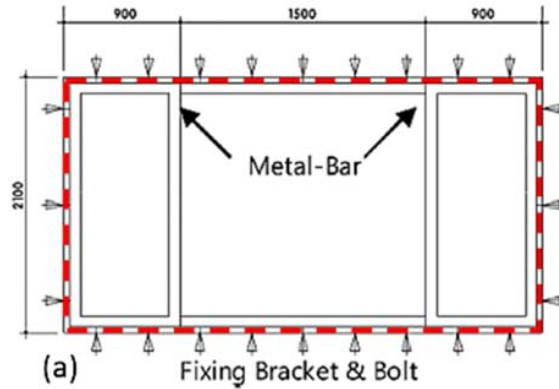

Fig. 2 Two windows model (a) window considered one panel, and (b) window considered three separate panels

TABLE I
DIMENSION AND CHARACTERISTICS OF BASELINE STRUCTURES

Properties	Model 1	Model 2
Apartment plan dimension	36m × 10.7m	
No. of stories	10	
Height per stories	2.6m	
Roof type	Flat	
No. of window panels	1	3
Window dimension	3.3m × 2.1m	0.9m × 2.1m 1.5m × 2.1m

TABLE II
STATISTICS OF RESISTANCE FOR COMPONENTS OF WINDOW

Component	Mean (kPa)	COV	Distribution
Glass	2.25	0.25	Normal
Metal bar	0.81	0.10	Normal

C. Wind Load Statistics

ASCE 7-10 [8] was used to determine wind load (W) in (3). ASCE 7-10 defines two types of structural elements subjected to wind load: (1) Main wind-force resisting systems (MWFRS), and (2) Components and cladding (C&C). For outside windows, they are part of the components and cladding. The total height of structure is 26 m, thus wind load pressure acting on this C&C in this building can be calculated as:

$$W = q_z G C_p - q_h G C_{pi} \tag{4}$$

where q_z = velocity pressure evaluated at height z , q_h = velocity

pressure evaluated at mean roof height h , GC_p = product of gust factor and external pressure coefficient, and GC_{pi} = product of gust factor and internal pressure coefficient.

TABLE III
SUMMARY OF STATISTICAL WIND LOAD PARAMETERS

Parameters	Category	Mean-to-Nominal	COV	CDF
K_z	Exposure B	1.01	0.19	Normal
	Exposure C	0.96	0.14	Normal
	Exposure D	0.96	0.14	Normal
K_d	C & C	1.05	0.16	Normal
	Enclosed	0.83	0.33	Normal
GC_{pi}	Partially Enclosed	0.92	0.33	Normal
	Zone 4 (Mid)	0.95	0.12	Normal
GC_p	Zone 5 (Edge)	0.95	0.12	Normal
	K_{zt}	Deterministic (1)		

The velocity pressure evaluated at height z is given by:

$$q_z = 0.613K_zK_{zt}K_dV^2 \quad (\text{unit: } N/m^2) \quad (5)$$

in which K_z = the velocity pressure exposure factor, K_{zt} = the topographic factor, K_d = the wind directionality factor, V = the basic wind speed in m/s .

Following ASCE 7-10, nominal value for these parameters could be found. From the nominal value of these parameters, the statistical distribution of wind load parameters could be obtained based on work done by Ellingwood and Tekkie [6]. Therefore, mean value of this parameters is the multiplication of mean-to-nominal value with the nominal value from ASCE 7-10 and standard deviation is the COV multiply by mean value.

D. Calculation of Probability of Failure for a Window at Each Floor

Monte Carlo Simulation (MCS) method had been used to generate probabilistic wind load (W) and window resistance capacity (R). As can be seen in Fig. 3, starting from the minimum wind speed we generated 5,000 random K_z , K_d , GC_{pi} , GC_p , and window resistances capacity by sampling from their normal distributions in Tables II and III. Then, followed limit states in (3), 5,000 damage array could be obtained. From this we could determine probability of failure (P_f) at the previously defined wind speed. By increasing wind speed and repeated the step until all failure occurred ($P_f = 1$), a fragility function in term of wind speed could be calculated.

Each windows' probability of failure was independent from one to another. Fig. 4 shows wind fragility for each window in Model 1 window configuration, there were totally 80 different windows (8 windows in each floor); however, according to ASCE 7-10, the product of gust factor and external pressure coefficient (GC_p) depends on location of the component and cladding, thus there were 20 unique probability of failure for these 80 windows. As can be seen in Fig. 4, there were two unique windows panel at each floor, one at the edge and the other one was in the middle of building. Alternatively, in Model 2 there are 30 unique probability of failure for all windows panel in the entire structure.

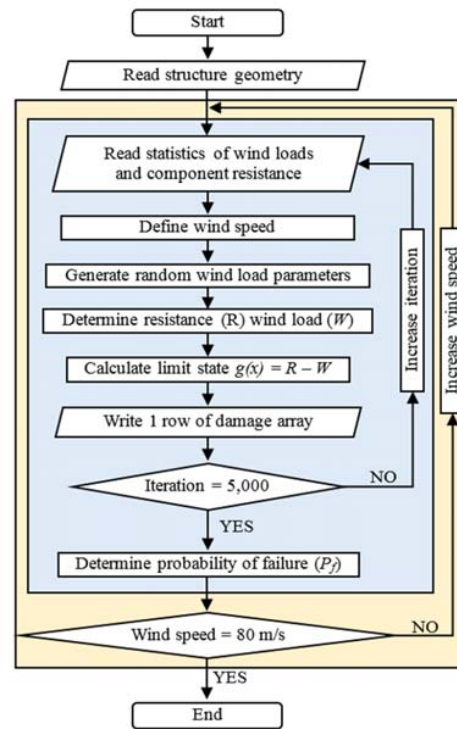

Fig. 3 MCS method algorithm flowchart

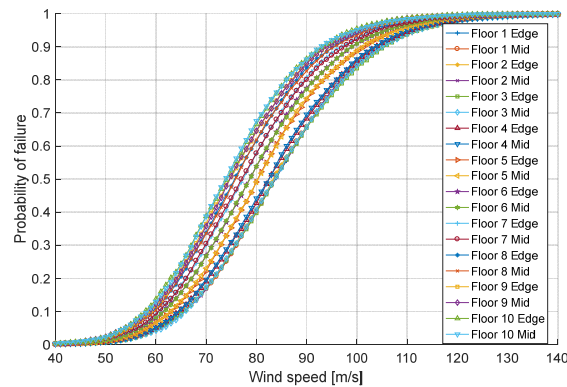

Fig. 4 Probability of failure for Model 1 window at each floor level

In Fig. 4, a fully enclosed structure was assumed; the structure became partially enclosed when the first window failure occurs. The individual window fragility curves were used in the next section to calculate the fragility for complete window system where the probability of failure for individual will change to partially enclosed after the first window failure occurred.

III. WIND FRAGILITY FOR WINDOW SYSTEM

Four level of damage were defined in this study for system limit state, they were: DS1, DS2, DS3, and DS4; detail of these damage states was shown in Table IV. A simple system reliability concepts were utilized to construct fragility.

Assumed statistically independent panel failures, the fragility for the case of fewer than j windows failure conditioned on wind speed can be written as [1]:

$$F_{system}(N_f \leq j|V) = \sum_{i=0}^j F_{system}(N_f = i|V) \quad (6)$$

where V = wind speed, N_f = number of failed windows, and $F_{system}(N_f=i|V)$ = failure of i numbers of window amongst total n windows. This means that from the individual window fragility function, combination of window failure was made by using binomial probability distribution function. All possible window failure amongst total number of failure (i) in each damage state were combined to determine the probability of failure for window system in that damage state.

TABLE IV
DEFINITION OF DAMAGE STATES

Damage states (DS)	Damage level	Percentage of windows fail
1	Minor	No more than one window
2	Moderate	Fewer than 10% of total windows
3	Severe	Fewer than 20% of total windows
4	Destructive	Fewer than 33% of total windows

Model 1 and Model 2 had a total of 80 and 240 windows, respectively. The failure of an individual window at each floor was calculated using the procedure in the previous section (Section III D) and then using (6), the system failure probability for each limit state at a given wind speed was determined. This procedure repeated for wind speed ranging from 20 m/s to 80 m/s. Additionally, two assumptions were required in this system analysis:

- 1) Window failures are statistically independent.
- 2) The internal pressure condition is assumed to be an “enclosed” before the failure of the first window, and “partially enclosed” after the first window fails.

IV. RESULTS

After determining window system failure probability for each step of wind speed from 20 m/s to 80 m/s, Fig. 5 shows a comparison of window system fragilities in different exposure category. Exposure B is urban and suburban areas, Exposure C is terrain with scatter building, while Exposure D is flat or near water surface. Furthermore, probabilities of failure for different components of window (frames and glass) were shown in Fig. 6. We could see that failure due to metal bar frames was more critical than that of glass. This was anticipated from the experiment results.

In ASCE 7-2010, the product of gust factor and external pressure coefficient (GC_p) is depends on location of the component and cladding, in leeward wall (downwind wall) this coefficient had higher value than those of windward wall (wall facing the wind) the result of fragility could be seen in Fig. 7. Higher probability of failure was on the leeward wall windows. Fig. 8 shows the difference between Model 1 and Model 2 configuration as well as different resistance capacity from metal bar and glass. Model 2 had higher number of windows, this increased the combination of fail window in each damage state,

consequently the probability of failure for this configuration was higher than Model 1.

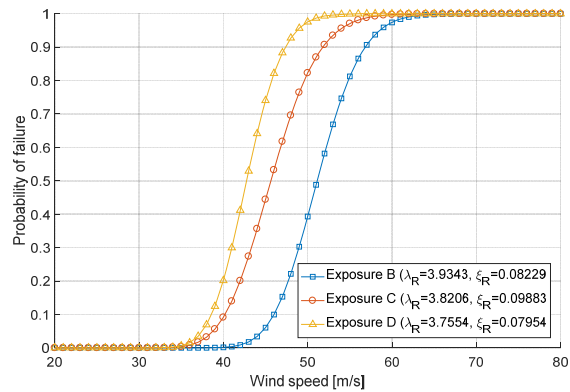

Fig. 5 Comparison window system fragilities for different exposures categories

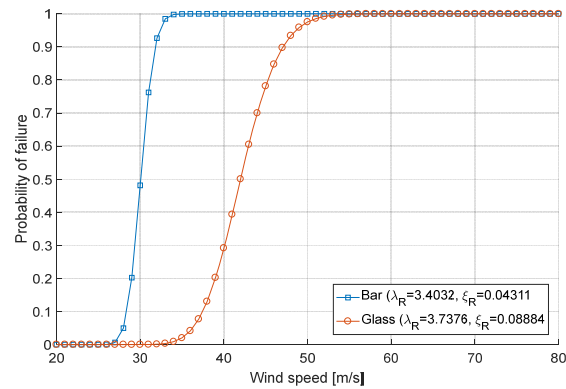

Fig. 6 Comparison window system fragilities for different resistance component

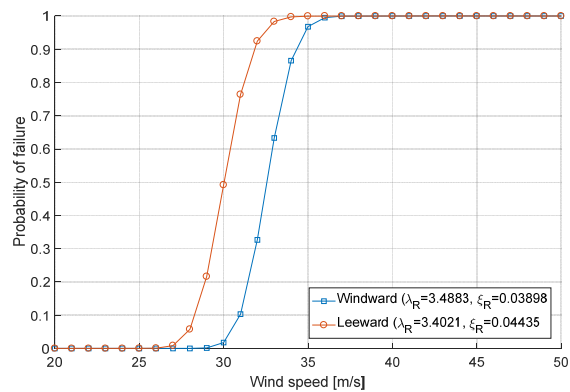

Fig. 7 Comparison of window system fragilities for different wind direction

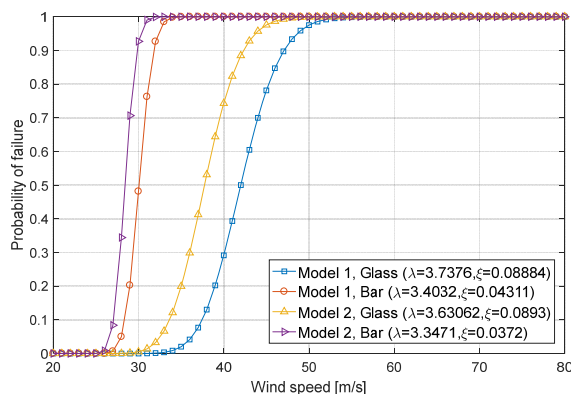

Fig. 8 Comparison of window system speed fragilities for different window configuration model

V. CONCLUSIONS

Two different windows configuration had been modeled to analyze their performance under high wind loads by means of fragility analysis. A MCS method had been used to determine analytical fragility, which depends on damage data from statistical value of wind load parameters and resistance capacity parameters. The procedure began by determining the probability of failure for each unique window on the entire structure, then from this probability of failure a simple system reliability concepts were utilized to construct system fragility based on predefined system limit states.

Multiple comparisons had been made to study the effect of exposure, resistance component, wind direction, and especially the comparison between the two model. From the window system fragility results, we could make the following conclusions:

- 1) Individual window became more vulnerable as they located at higher floor, especially those close to the edge of building. This is due to the building causes the wind to separate at the edges and to reattach downstream which result in different between GC_p coefficient in the middle zone and in the edge of building.
- 2) Windows located on leeward wall had higher probability of failure and higher probability of failure when they are located at the edge zone of building.
- 3) With higher number of window panels, Model 2 become more susceptible to failure due to wind load than Model 1 window configuration.

ACKNOWLEDGMENT

This research was supported by a grant [MPSS-NH-2015-79] through the Disaster and Safety Management Institute funded by Ministry of Public Safety and Security of Korea government.

REFERENCES

- [1] G. Carpenter, "Typhoon Maemi loss report 2003," Guy Carpenter & Co. Ltd., Asia Pacific Practice, Tower Place, London, EC3R 5BU, 16, 2003.
- [2] K. H. Lee, and D. V. Rosowsky, "Fragility assessment for roof sheathing failure in high wind regions," *Engineering Structures*, 2005, vol. 27, no. 6, pp. 857–868.
- [3] ASTM E 1300-04 "Standard practice for determining load resistance of glass in buildings," West Conshohocken, PA, 19428-2959, 2004.
- [4] K. Porter, "Beginner's guide to fragility, vulnerability, and risk," *Encyclopedia of Earthquake Engineering*, 2015, pp. 235–260.
- [5] P. J. Vickery, P. F. Skerlj, J. Lin, L. A. Twisdale Jr, M. A. Young, and F. M. Lavelle, "HAZUS-MH hurricane model methodology. II: Damage and loss estimation," *Natural Hazards Review*, 2006, vol. 7, no. 2, pp. 94-103.
- [6] B. R. Ellingwood, and P. B. Tekie, "Wind load statistics for probability-based structural design," *Journal of Structural Engineering*, 1999, vol. 125, no. 4, pp. 453–463.
- [7] H. J. Ham, W. Yun, H. J. Kim, and S. Lee, "Evaluation of Extreme Wind Fragility for Balcony Windows Installed in Mid/Low-Rise Apartments," *Journal of Korean Society of Hazard Mitigation*, 2014, vol. 14, no. 1, pp. 19–26.
- [8] American Society of Civil Engineers, "Minimum design loads for buildings and other structures (Vol. 7)," *American Society of Civil Engineers*, 2010.