

Innovation and Analysis of Vibrating Fork Level Switch

Kuen-Ming Shu, Cheng-Yu Chen

Abstract—A vibrating-fork sensor can measure the level height of solids and liquids and operates according to the principle that vibrations created by piezoelectric ceramics are transmitted to the vibrating fork, which produces resonance. When the vibrating fork touches an object, its resonance frequency changes and produces a signal that returns to a controller for immediate adjustment, so as to effectively monitor raw material loading. The design of the vibrating fork in a vibrating-fork material sensor is crucial. In this paper, ANSYS finite element analysis software is used to perform modal analysis on the vibrations of the vibrating fork. In addition, to design and produce a superior vibrating fork, the dimensions and welding shape of the vibrating fork are compared in a simulation performed using the Taguchi method.

Keywords—Vibrating fork, piezoelectric ceramics, sound wave, ANSYS, Taguchi method, modal analysis.

I. INTRODUCTION

TECHNOLOGICAL advancement has affected choices and use of manufacturing processes. Previously, in loading liquid, granular, or powdered objects, verification through instrument measurement was required before the next step could be taken. This was time-consuming, and the accuracy of repeated measurements differed. However, the development of current sensors has enabled substantial improvements in measurement time and repetition accuracy. Sound wave energy has various applications: ultrasonic welding and sonar systems in mechanical industries, medical sonic scanners, and instruments used by opticians to clean glasses are all characterized by sound wave transmission.

A vibrating-fork sensor, which uses the vibrations of a vibrating fork to measure the switch point after a level surface is reached, is suitable for measuring liquid and powdered level surfaces. It operates according to the principle that when the vibrating fork and the object being measured touch, the vibrating fork is prevented from vibrating fully by resistance, at which time a signal is produced and returns to a controller for sensing or adjustment.

Vibrating forks can be used to perform online detection and do not involve problems related to electrical fires. Thus, they are often used in chemical and biomedical applications [1]-[3] and are also effective for gauging the density and viscosity of engine oil [4]. In addition, they can be applied in sensing temperature, pressure, and stress [5], [6], as well as acceleration

[7]. Vibrating-fork level sensors can sense the level height of liquid or powdered surfaces. Zhang et al. [8] used a vibrating-fork level sensor to investigate the reaction characteristics of liquids with different viscosities.

In the analysis of horn design for ultrasonic welding, ultrasonic-assisted cutting, and ultrasonic-assisted rotation welding [9], [10], ANSYS finite element analysis reduces the processing time and affords vibration accuracy.

The dimensions and shapes of vibrating forks affect their resonance, creating disparity in the accuracy and repetition rate during sensing. Thus, this paper discusses the resonance and sound wave conduction of vibrating forks and analyzes their vibrations. Modal analysis was performed using ANSYS finite element software, and the optimal dimensions of a vibrating fork were determined. After vibrating forks were fabricated, they underwent testing to achieve an optimal vibrating fork design.

II. METHODS AND PROCEDURES

In this study, computer-aided design was applied to design multiple vibrating forks featuring different geometries for experimentation. ANSYS finite element analysis was performed to determine the numerical values of the vibrating forks when they resonated. These values were recorded and, by using the Taguchi method, the optimal combination closest to the target was determined. Finally, testing was again undertaken to verify whether this method enabled effective improvements.

The research procedures comprised the following four stages: The first stage involved creating geometric models of the vibrating forks. Vibrating fork modules were established using SolidWorks (version 2012) graphics software for rendering, and a characterization method was applied to construct models. After individual parts and mechanisms were separately rendered, they were assembled. When the part sizes were modified, the part files could be opened and the parts modified. Furthermore, during finite element analysis, the parameters of different parts could be separately adjusted to achieve the simulated accuracy.

The second stage comprised ANSYS finite element analysis. The software used combines structural; fluid; electric, magnetic, sound, and other fields; and integrated finite analysis software. Experiments were based on the frequencies within the structural field. In the ANSYS finite element analysis, experimental designs were created for the following four factors: tip shape of the prongs, chamfer dimensions, fork length, and welding shape.

Kuen-Ming Shu is with the Dept. of Mech. and Computer-Aided Eng., National Formosa University, Taiwan (phone: 886-5-6315327; fax: 886-5-6315310; e-mail: kmshu@nfu.edu.tw).

Cheng-Yu Chen is with the Dept. of Mech. and Computer-Aided Eng., National Formosa University, Taiwan.

The Taguchi method was used for experimental design in the third stage. To reduce the number of experiments and amount of time expended, yet maintain high experimental standards, the Taguchi method was selected for the statistics of the experimental values. A low cost, highly effective quality engineering calculation method, the Taguchi method emphasizes that the goal of high product quality is achieved not through the number of experiments, but through the design of the experiments.

The fourth stage involved verifying the optimal vibrating fork fabrication and comparing the experimental results. ANSYS finite element analysis software was used to analyze and design the vibrating forks, and according to the nominal-the-best characteristic in the Taguchi method, 140 Hz was set as the target. Finally, the vibrating fork that achieved a frequency nearest to the target frequency was obtained.

Fig. 1 depicts the vibrating-fork level sensor developed in this study. SUS316L stainless steel, commonly used in the food industry and in surgical instruments, was used to fabricate the fork; Table I shows the composition of the SUS316L stainless steel. With a low carbon content and the addition of

molybdenum, SUS316L stainless steel features greater corrosion resistance and heat treatability compared with generic 304 stainless steel.

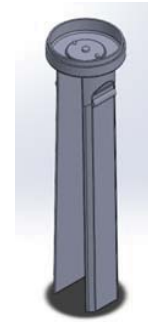

Fig. 1 Diagram of vibrating fork

TABLE I
COMPOSITION OF SUS316L

Composition	C	Si	Mn	P	S	Ni	Cr	Mo
SUS316L	<0.08	<1.0	<2.0	<0.045	<0.030	10.0–14.0	16.0–18.0	2.0–3.0

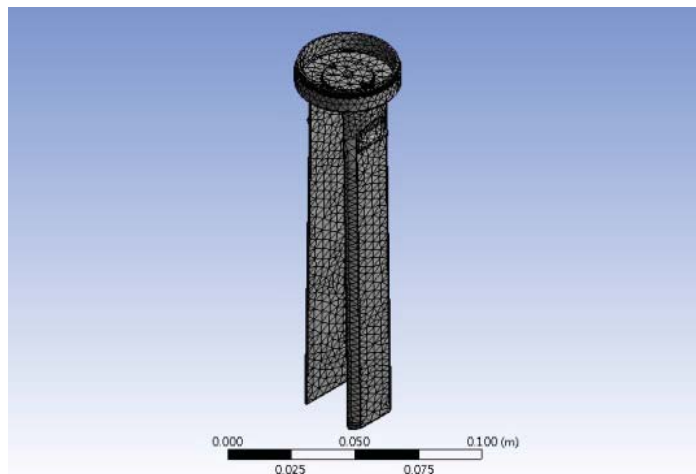

Fig. 2 100% meshed geometry

III. RESULTS AND DISCUSSION

A. ANSYS Simulation Analysis

After SolidWorks graphics software was employed to render the vibrating fork, the rendering was input into ANSYS finite element analysis software for analysis, and modal analysis was used to obtain the resonance frequency. Fig. 2 depicts the 100% meshed geometry used to obtain the resonance frequency.

B. Taguchi Method Analysis

The three influential factors used in this study were the prong tip shape, the fork length, and the welding shape, as shown in Fig. 3. For each factor, three levels were obtained (Table II).

According to the control factors and levels, an $L_9(3^4)$ orthogonal array was selected and can contain a maximum of four factor values. Table III shows the level configuration of the experiments and factors.

TABLE II
FACTORS AND LEVELS

Factor	A. Prong tip shape	B. Vibrating fork length	C. Welding shape
Level 1	Flat	130mm	Flat
Level 2	45° bevel	120mm	Circular arc
Level 3	Round	125mm	Trapezoidal

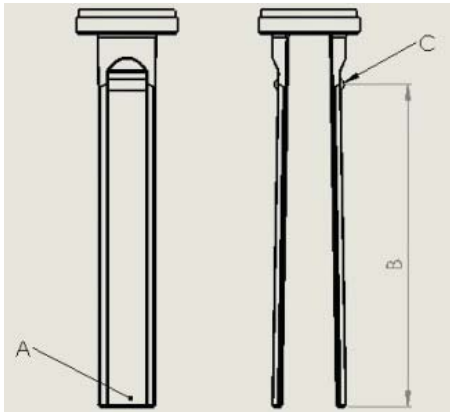

Fig. 3 Vibrating fork factors

ANSYS simulation experiment. The obtained frequency was 140.4 Hz (Fig. 4). Fig. 5 shows a stress diagram. The error with the 141.2-Hz target frequency was only 0.6%, and the acceptable range for the resonance frequency of the vibrating-fork level sensor was $\pm 10\%$, conforming to the resonance frequency.

TABLE III
EXPERIMENT AND FACTOR LEVEL CONFIGURATION

Experiment	Factor	A	B	C
1		1	1	1
2		1	2	2
3		1	3	3
4		2	1	2
5		2	2	3
6		2	3	1
7		3	1	3
8		3	2	1
9		3	3	2

Optimal dimension parameter data were input into an

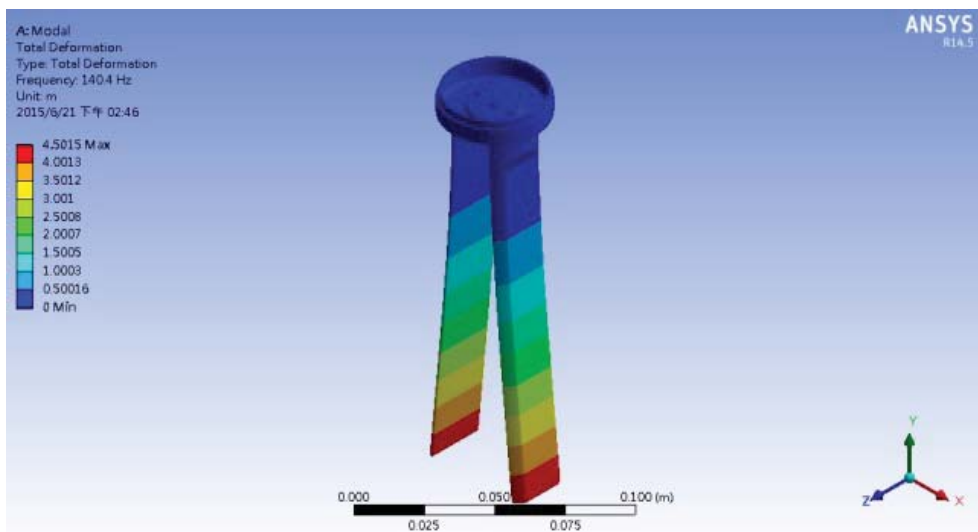

Fig. 4 Frequency diagram for optimal parameter A1B1C1

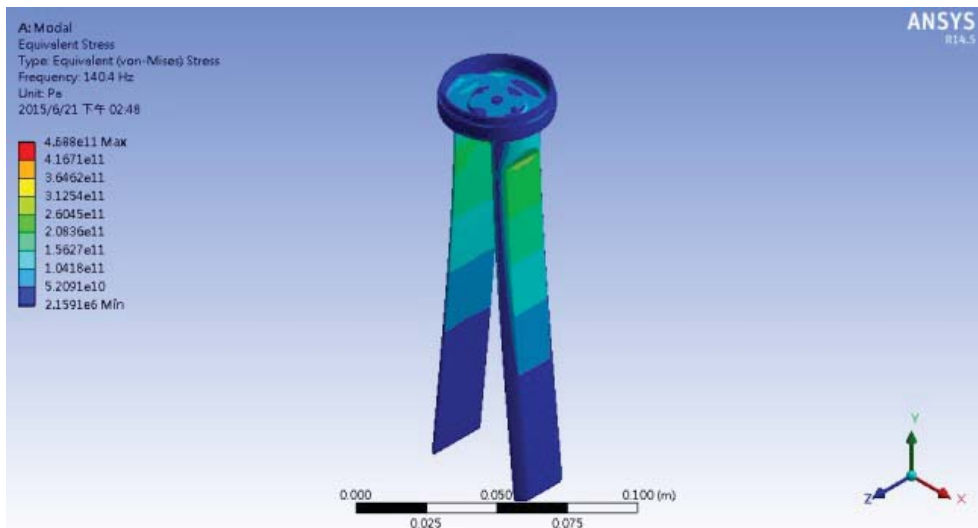

Fig. 5 Stress diagram for optimal parameter A1B1C1

C. Vibrating Fork Frequency Experiments

To verify whether the frequency produced by the designed vibrating fork during actual resonance corresponded to the simulation results, three vibrating forks featuring different shapes, A1B1C1, A2B1C1, and A3B1C1 (Figs. 6-8), were fabricated and physically tested. Three fluids, water, insulating oil, and engine oil, were used for experimentation; Table IV presents the viscosity coefficients.



Fig. 6 Vibrating fork A1B1C1



Fig. 7 Vibrating fork A2B1C1



Fig. 8 Vibrating fork A3B1C1

TABLE IV
VISCOSITY COEFFICIENTS

Fluid	Viscosity (cP = mPa·s)	
Water	0°C	1.792
	20°C	1.002
	40°C	0.656
	60°C	0.469
	80°C	0.357
Engine oil	SAE 10 (20°C)	65
	SAE 40 (20°C)	319
Insulating oil	50°C	≤9.6*10 ⁻⁶ m ² /s

TABLE V

FLUID MEASUREMENTS USING FLAT-TIPPED VIBRATING FORK A1B1C1

Fluid	Parameter	10mm	15mm	20mm	25mm	30mm
Water	Wave peak (V)	2.32	1.92	1.68	1.52	1.52
	Frequency (Hz)	131.8	127.7	126.1	123.0	118.3
Engine oil	Wave peak (V)	0.96	0.64	0.48	×	×
	Frequency (Hz)	136.1	1.887k	2.439k	×	×
Insulating oil	Wave peak (V)	2.16	1.66	1.28	1.04	0.96
	Frequency (Hz)	134.0	130.9	128.8	216.9	200.0

TABLE VI

FLUID MEASUREMENTS USING 45° BEVELED-TIPPED VIBRATING FORK A2B1C1

Fluid	Parameter	10mm	15mm	20mm	25mm	30mm
Water	Wave peak (V)	2.32	1.92	1.60	1.60	1.52
	Frequency (Hz)	135.1	134.2	127.4	125.2	122.7
Engine oil	Wave peak (V)	1.20	0.80	0.56	×	×
	Frequency (Hz)	136.4	234.9	318.5	×	×
Insulating oil	Wave peak (V)	2.72	1.64	1.36	1.12	0.96
	Frequency (Hz)	136.2	133.9	131.1	128.4	206.2

TABLE VII

FLUID MEASUREMENTS USING ROUND-TIPPED VIBRATING FORK A3B1C1

Fluid	Parameter	10mm	15mm	20mm	25mm	30mm
Water	Wave peak (V)	3.20	2.00	1.92	1.72	1.60
	Frequency (Hz)	137.0	133.9	132.8	128.0	125.8
Engine oil	Wave peak (V)	2.23	1.12	0.72	×	×
	Frequency (Hz)	128.2	115.5	209.5	×	×
Insulating oil	Wave peak (V)	3.10	2.00	1.54	1.02	0.86
	Frequency (Hz)	135.5	132.4	128.3	114.5	113.2

Tables V-VII display the resonance frequency and wave peak height experimental results obtained under various conditions. Apparent in the tables, the vibrating forks with 45°-beveled and round prong tips were more stable during testing, whereas the flat-tipped vibrating fork, A1B1C1, more easily exhibited interference. Changes in the shape of the prong tips created no substantial changes in resonance. However, the wave peak and frequency differed substantially. Compared with the flat-tipped vibrating fork, the forks with 45°-beveled and round tips were more able to detect subtle changes.

IV. CONCLUSION

In this study, ANSYS finite element analysis software was used to perform modal analysis on the vibrations of vibrating forks. According to the experimental results, using ANSYS and the Taguchi method effectively reduced the amount of time expended on trial and error. The sensing experiments revealed that the most crucial factor was fork length. To maintain the resonance frequency at approximately 140 Hz, the vibrating fork length had to be 130 mm, controlling the error to within 10%. The shape of the vibrating fork prong tip exerted no substantial influence on resonance.

ACKNOWLEDGMENT

The authors would like to thank for the financial support from National Science Council in Republic of China under the contract number of MOST103-2622-S-150-001-CC3

REFERENCES

- [1] P. Hauptmann, R. Lucklum, A. Puttmer, B. Henning, Ultrasonic sensors for process monitoring and chemical analysis: state-of-the-art and trends, *Sens. Actuators A*, 67 (1998), p. 32
- [2] D.S. Ballantine, R.M. White, S.J. Martin, A.J. Ricco, E.T. Zellers, G.C. Frye, H. Wohltjen, *Acoustic Wave Sensors*, Academic Press, San Diego, CA, 1997.
- [3] B. Jakoby, M.J. Vellekoop, Viscosity sensing using a Love-wave device, *Sens. Actuators A*, 68 (1998), p. 275
- [4] J.Sorab, R.H. Allen, B. Gonik, Tactile sensory monitoring of clinician-applied forces during delivery of newborns, *IEEE Trans. Biomed. Eng.*, 35 (12) (1988), p. 1090.
- [5] E.P. Eernisse, R.W. Ward, R.B. Wiggins, Survey of quartz bulk resonator sensor technologies *IEEE Trans. Ultrason. Ferroelectr. Freq. Control*, 35 (1988), p. 3230
- [6] H. Brandle, W. Gribi, K.-Y. Haffner, Device for measuring gas density, US Patent 5,421,190, 1995.
- [7] S. Kudo, Consideration on temperature characteristics of sensitivity in quartz tuning fork gyroscope, *Jpn. J. Appl. Lett.*, 37 (1) (1998), p. 2872.
- [8] Jian Zhang, Changchun Dai, Xiaodi Su, Sean J. O'Shea, Determination of liquid density with a low frequency mechanical sensor based on quartz tuning fork, *Sensors and Actuators B* 84 (2002) 123–128.
- [9] Kuen-Ming Shu, Wen-Hsiang Hsieh, Hoa-Shen Yen, On the Design and Analysis of Acoustic Horns for Ultrasonic Welding, *The Transactions of The Canadian Society for Mechanical Engineering (SCI)*, 2013, pp905-916
- [10] Kuen-Ming Shu, Wen-Hsiang Hsieh, Hoa-Shen Yen, Design and Analysis of Acoustic Horns for Ultrasonic machining *Applied Mechanics and Materials (E1)*, 2013, pp662-666