

Analysis of Injection-Lock in Oscillators versus Phase Variation of Injected Signal

M. Yousefi, N. Nasirzadeh

Abstract—In this paper, behavior of an oscillator under injection of another signal has been investigated. Also, variation of output signal amplitude versus injected signal phase variation, the effect of varying the amplitude of injected signal and quality factor of the oscillator has been investigated. The results show that the locking time depends on phase and the best locking time happens at 180-degree phase. Also, the effect of injected lock has been discussed. Simulations show that the locking time decreases with signal injection to bulk. Locking time has been investigated versus various phase differences. The effect of phase and amplitude changes on locking time of a typical LC oscillator in 180 nm technology has been investigated.

Keywords—Injection-lock oscillator, oscillator, analysis, phase modulation.

I. INTRODUCTION

IN the signal injection to oscillator, a signal with frequency close to that of the oscillator is applied as injection signal. The signal injection and oscillator locking is investigated for the first time by Adler [1] Analysis of oscillator behavior has been investigated in several papers and in most of them, the effect of input signal power, input frequency and behavioral modeling of this phenomenon have been discussed [2]. Phase analysis which is the main idea of this phenomenon, has been mentioned in these papers. Another point of view is the analysis in time and phase domain. The proposed model in these reports is based on impulse sensitivity [3], [4].

Time domain delayed model has been proposed which is not proper for time and signal amplitude analysis. In Razavi's paper, different analyses such as locking time analysis, the effect of the oscillator non-linearity in this phenomenon and phase noise have been investigated [5]. Injection-lock oscillators are used in modern analog systems like receivers [6], frequency dividers [7], [8], phase-locked loops [9], [10], and multipliers. In most of these applications, using this technique reduces the power consumption and area required for hardware implementation.

If an oscillator with resonance frequency, ω_0 is stimulated with another signal with frequency of ω_{inj} , considering the distance between ω_0 and ω_{inj} , and oscillator parameters like quality factor, output signal amplitude and injection signal amplitude, the effect of injected signal will be different [11].

In this paper, the effect of phase variation of injected signal

M. Yousefi is with the department of electrical Engineering, Faculty of Engineering, Azarbaijan Shahid Madani University, Iran (corresponding author to provide phone: +989143067540; e-mail: m.yousefi@azaruniv.edu).

N. Nasirzadeh is with Faculty of electrical and computer engineering, University of Tabriz, IrAN (e-mail: nnasirzadeh@tabrizu.ac.ir).

on the amplitude and frequency of the output signal and locking time has been discussed and simulated. For this purpose, basic equation this phenomenon are presented in Section II. Section III, involves the effect of signal injection versus phase changes and its effect on the output signal amplitude and locking time. Simulation results for a typical LC oscillator are present in Section IV. Conclusions are in Section V of this paper.

II. OSCILLATOR

For simple investigation of injected signal behavior on the oscillator, consider Fig. 1. In this paper, the structure of an oscillator with feedback has been shown. A phase difference of 180 degree is generated in feedback path. Applying the injected signal generates an additional phase difference in feedback path. θ_0 is the phase difference of the injected signal.

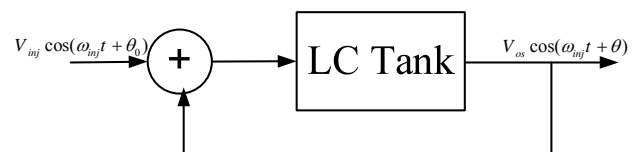

Fig. 1 Block diagram of an oscillator with injection signal

To keep the oscillations, the oscillator omits the generated phase difference. In this condition, the frequency of the oscillator changes for free-running frequency (with this assumption that injected frequency is in locking bandwidth of injection lock). As shown in Fig. 1, output voltage after adding injected signal and oscillator output signal is:

$$V_x = V_{inj} \cos(\omega_{inj}t + \theta_0) + V_{os} \cos(\omega_{inj}t + \theta) \quad (1)$$

$$V_x = A \cos(\omega_{inj}t) - B \sin(\omega_{inj}t) \quad (2)$$

V_{inj} is the amplitude of the injected signal, V_{os} is the amplitude of the oscillator output signal and Q is the quality factor of the oscillator. Values A and B are defined in the appendix. Voltage V_x , can be expressed as sine signal:

$$V_x = V_m \cos(\omega_{inj}t + \varphi) \quad (3)$$

φ and V_m are defined in the appendix. Noting that $V_{inj} \ll V_{os}$, equation for V_x can be simplified as:

$$V_x \approx V_{os} \cos(\omega_{inj}t + \varphi) \quad (4)$$

If signal V_x is passed through an LC tank, the output

voltage will be:

$$(V_{out} = V_m \cos(\omega_{inj}t + \varphi + \tan^{-1}[\omega_0 - \omega_{inj} - \frac{d\varphi}{dt}])) \quad (5)$$

If we equate (3) with output of the oscillator, it can be seen that:

$$\varphi + \tan^{-1}[\omega_0 - \omega_{inj} - \frac{d\varphi}{dt}] = \theta \quad (6)$$

If we calculate the derivative of (6):

$$\frac{d\varphi}{dt} = \frac{V_{os}^2 + V_{os}V_{inj}(\sin\theta_0\sin\theta + \cos\theta\cos\theta_0)}{V_{os}^2 + V_{inj}^2 + 2V_{os}V_{inj}(\sin\theta_0\sin\theta + \cos\theta\cos\theta_0)} \frac{d\theta}{dt} \quad (7)$$

As the injected signal has smaller amplitude in comparison to the output signal of the oscillator, equation can be approximated as:

$$\frac{d\varphi}{dt} \approx \frac{d\theta}{dt} \quad (8)$$

Using trigonometry relationships:

$$\tan(\theta - \varphi) = \frac{V_{inj}(\cos\theta_0\sin\theta - \cos\theta\sin\theta_0)}{V_{os} + V_{inj}(\sin\theta_0\sin\theta + \cos\theta\cos\theta_0)} \quad (9)$$

with approximating (9):

$$\tan(\theta - \varphi) \approx \frac{V_{inj}(\cos\theta_0\sin\theta - \cos\theta\sin\theta_0)}{V_{os}} \quad (10)$$

The following result can be achieved:

$$\frac{d\theta}{dt} = \omega_0 - \omega_{inj} - \frac{\omega_0 V_{inj}}{2Q V_{os}} \sin(\theta - \theta_0) \quad (11)$$

If the frequency of injected signal is within the bandwidth locking can be achieved. This range is given by (12) based on discussion and analyses:

$$\omega_L = \frac{\omega_0 V_{inj}}{2Q V_{osc}} \quad (12)$$

Equation (11) can be rewritten by using $\Phi = \theta - \theta_0$:

$$\frac{d\Phi}{dt} = \omega_0 - \omega_{inj} - \omega_L \sin\Phi \quad (13)$$

The time interval which is required for oscillator to be stable after signal injection or in the other words, locked is called locking time. After locking time, phase does not change anymore ($d\Phi/dt=0$), so:

$$\Phi = \sin^{-1}\left(\frac{\omega_0 - \omega_{inj}}{\omega_L}\right) \quad (14)$$

After phase difference generation in injected signal, locking condition is reached again. Final phase difference after locking, θ_2 can be achieved from (14):

$$\theta_2 - \theta_0 = \sin^{-1}\left(\frac{\omega_0 - \omega_{inj}}{\omega_L}\right) \quad (15)$$

$$\theta_2 = \theta_1 + \theta_0 \quad (16)$$

Before locking, structure was in locking condition and output signal phase difference with injected signal is equal to:

$$\theta_1 = \sin^{-1}\left(\frac{\omega_0 - \omega_{inj}}{\omega_L}\right) \quad (17)$$

So, from (17), it can be seen that with generating phase difference in injected signal, output signal will have equal phase difference with injected signal.

III. ANALYSIS OF INJECTED SIGNAL PHASE CHANGE ON LOCKING TIME

Analysis of locking time when the phase of injected signal changes is investigated in the following. Equation (13) can be rewritten as:

$$dt = \frac{d\Phi}{\omega_0 - \omega_{inj} - \omega_L \sin(\Phi)} \quad (18)$$

$$\sin(\Phi) = \frac{2\tan(\Phi/2)}{1 + \tan^2(\Phi/2)} \quad (19)$$

Using variable change $u = \tan(\Phi/2)$ and with the assumption that the frequency of injected signal is within the bandwidth of injection-lock:

$$\alpha\omega_L = \omega_0 - \omega_{inj} \quad (20)$$

$$0 < \alpha < 1$$

Replacing in the equations above:

$$\frac{d\Phi}{\omega_L(\alpha - \sin(\Phi))} = dt \quad (21)$$

Equation can be written as:

$$\frac{2}{\alpha\omega_L} \frac{du}{u^2 - \frac{2u}{\alpha} + 1} = dt \quad (22)$$

$$\frac{2du/\omega_L}{(u-u_1)(u-u_2)} = dt \quad (23)$$

$$u_{1,2} = \frac{1}{\alpha} \pm \sqrt{\frac{1}{\alpha^2} - 1} \quad (24)$$

Using differential equations:

$$u = \frac{u_1 - u_2 K e^{t/K_1}}{1 - K e^{t/K_1}} \quad (25)$$

With initial condition at $t=0$, phase difference is equal to θ_1 .

$$\frac{u_1 - u_2 K}{1 - K} = \tan\left(\frac{\theta_1 - \theta_0}{2}\right) \quad (26)$$

$$K = \frac{\tan\left(\frac{\theta_1 - \theta_0}{2}\right) - u_1}{\tan\left(\frac{\theta_1 - \theta_0}{2}\right) - u_2} \quad (27)$$

The rate of phase variation at $t \rightarrow \infty$ is equal to 0. So:

$$\tan(\theta_2) = u_2 \tag{28}$$

In this section, we assume that an oscillator with resonance, ω_0 is stimulated with a signal frequency of, ω_{inj} and because the injected signal frequency is within locking bandwidth, oscillator has been locked. If in this condition, the phase of the injected signal changes, the free-running phase must vary to be able to lock again. With these comments, equation is true for this condition, too. So, the time interval for locking condition can be calculated from:

$$t = k_1 \ln \left(-\frac{53}{u_2 k} + \frac{25u_1}{u_2 k} + 25 \pm \sqrt{\left(-\frac{53}{u_2 k} + \frac{25u_1}{u_2 k} + 25 \right)^2 - \frac{4u_1}{u_2 k}} \right) \tag{29}$$

IV. SIMULATION RESULTS

As an example, the effect of phase difference and frequency of the injected signal on the oscillator has been investigated in a typical LC oscillator. Values of the components have been given in Table I. This structure has been simulated in 180 nm RFCMOS technology. Fig. 3 shows the output signal waveform of the peak detector which is at the output of the oscillator. Frequency of the oscillator is 2.4 GHz.

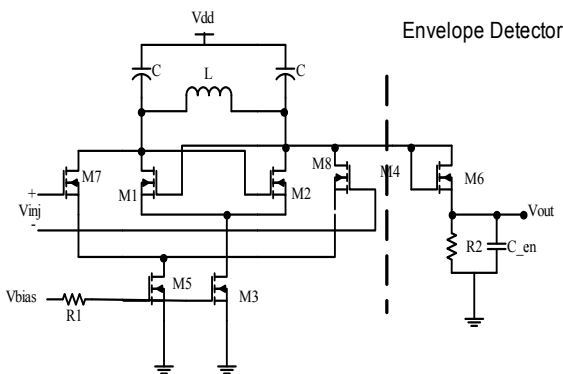

Fig. 2 The circuitry of the oscillator

TABLE I
VALUES OF THE COMPONENTS USED IN TYPICAL OSCILLATOR

Device	W/L	Device	Value	Device	Value
(W/L)M1	80/0.18	Vbias	0.5 volt	C	7 pF
(W/L)M2	80/0.18	R1	10 KΩ	Cen	20 pF
(W/L)M3	240/0.18	R2	80 KΩ	L	6 nH
(W/L)M4	20/0.18	Vdd	2 volt		

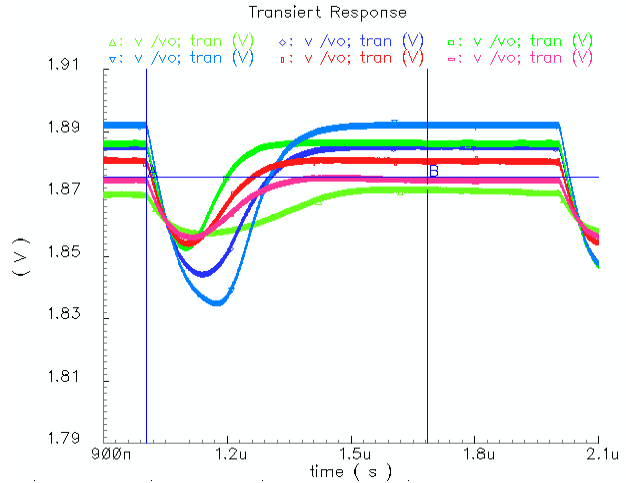

Fig. 3 Time response of the oscillator under injection after injected signal phase change versus different frequencies

In Fig. 3, the output signal of the peak detector versus the frequency of injected signal has been illustrated. It shows that the amplitude of the output signal of the peak detector changes for different frequencies of injected signal. Fig. 4 shows the output of the peak detector for 180 degrees phase change in injected signal with frequency of 2400 MHz. Also, in Fig. 5, the effect of phase change of the injected signal versus frequency has been shown. Simulations show that the output of the peak detector for 180 degrees has a lot of variation until locking again. Also, the locking time for oscillator to lock again depends on phase difference and the amplitude of the injected signal. In Fig. 6, locking time for different phases at three amplitude values of the injected signal has been shown. In this figure, locking time decreases as the amplitude of the injected signal increases.

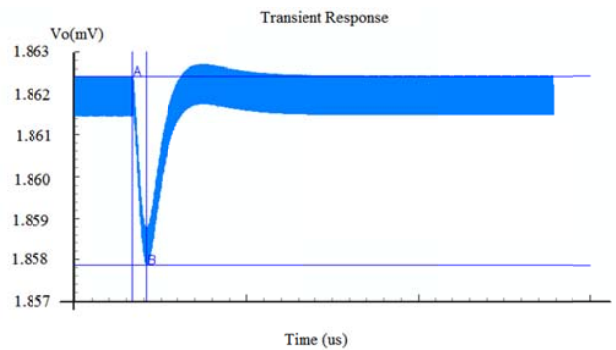

Fig. 4 Time response of the oscillator under injection versus 180 degree phase change

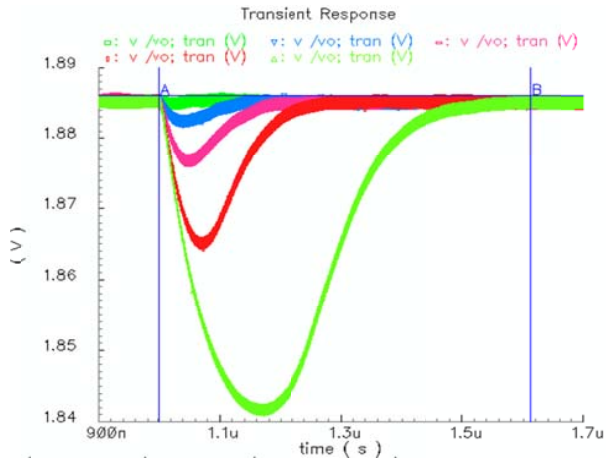

Fig. 5 Time response of the oscillator under injection for different phase changes of injected signals at a specific frequency of 2.4 GHz

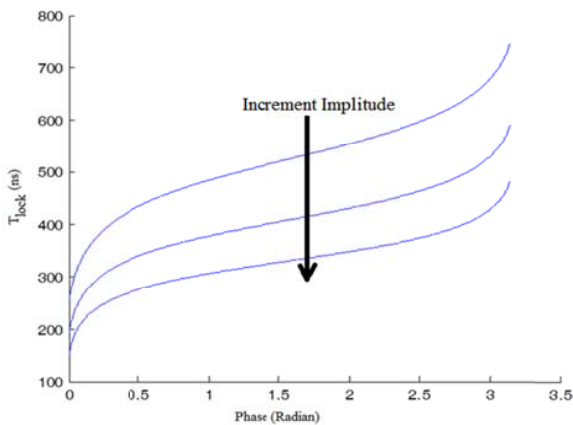

Fig. 6 Time interval for locking again for half period of phase changes versus different amplitudes of the injected signal

V.CONCLUSIONS

In this paper, the effect of phase changes on LC oscillator under injection-lock condition has been investigated. Also, time interval for locking again has been shown versus phase changes. Behavior of a typical LC oscillator structure in 180 nm technology has been discussed and simulated for phase difference of the injected signal and the effect of injected signal amplitude.

APPENDIX

$$A = V_{inj} \cos \theta_0 + V_{os} \cos \theta$$

$$B = V_{inj} \sin \theta_0 + V_{os} \sin \theta$$

$$V_m = \sqrt{V_{inj}^2 + V_{os}^2 + 2V_{inj}V_{os}(\sin\theta_0 \sin \theta + \cos\theta_0 \cos \theta)}$$

$$\tan(\varphi) = B/A$$

REFERENCES

- [1] R. Adler, "A study of locking phenomena in oscillators," Proc. IRE, vol. 34, no. 6, 1946, pp. 351–357.
- [2] A. Hajimiri and T. Lee, "A general theory of phase noise in electrical oscillators," IEEE J. Solid-State Circuits, vol. 33, no. 2, 1998, pp. 179–194, Feb.
- [3] L. Paciorek, "Injection locking of oscillators," Proc. IEEE, vol. 53, no.11, pp. 1723–1727, Nov. 1965.
- [4] F. Ramirez, E. d. Cos, and A. Suárez, "Nonlinear analysis tools for the optimized design of harmonic-injection frequency dividers," IEEE Trans. Microw. Theory Tech., vol. 51, no. 6, 2003, pp. 1752–1762.
- [5] B. Razavi, "A study of injection locking and pulling in oscillators," IEEE J. Solid-State Circuits, vol. 39, no. 9, pp. 1415–1424, Sep. 2004.
- [6] J. Bae, L. Yan, H-J. Yoo, "A low energy injection-locked FSK transceiver with frequency-to-amplitude conversion for body sensor applications," Solid-State Circuits, IEEE Journal of, 2011, vol. 46, no 4, p. 928-937.
- [7] S. Verma, H. R. Rategh, and T. H. Lee, "A unified model for injection locked frequency dividers," IEEE J. Solid-State Circuits, vol. 38, no.6, 2003, pp. 1015–1027.
- [8] M. Tiebout, "A CMOS direct injection-locked oscillator topology as high-frequency low power frequency divider," IEEE J. Solid-State Circuits, vol. 39, no. 7, 2004, pp. 1170–1174.
- [9] S. D. Toso, A. Bevilacqua, M. Tiebout, N. Da Dalt, A. Gerosa, and A. Neviani, "An integrated divide-by-two direct injection-locking frequency divider for bands s through Ku," IEEE Trans. Microw. Theory Tech., vol. 58, no. 7, 2010, pp. 1686–1695.
- [10] K. Yamamoto and M. Fujishima, "A 44- W 4.3-GHz injection-locked frequency divider with 2.3-GHz locking range," IEEE J. Solid-State Circuits, vol. 40, no. 3, 2005, pp. 671–677.
- [11] J.-C. Chien and L.-H. Lu, "Analysis and design of wideband injection locked ring oscillators with multiple-input injection," IEEE J. Solid-State Circuits, vol. 42, no. 9, 2007, pp. 1906–1915.

M. Yousefi was born in Marand, Iran, in 1989. He received the B.S. degree in electrical engineering from the University of Urmieh, Urmieh, Iran, in 2003, and the M.S. and Ph.D. degrees in electrical engineering from Faculty of Electrical and Computer Engineering, University of Tabriz, IRAN, in 2006 and 2015, respectively.

In 2015, he joined the Department of Electrical Engineering, Azarbaijan Shahid Madani University. His current research interests include data converter design, mixed signal circuits design and RF design integrated circuits.

N. Nasirzadeh received in B.S. degree in electrical engineering from University of Tabriz, Iran. He received M.Sc. in electrical engineering from University of Urmieh. His research interests are data converter design, mixed signal circuits design and RF integrated circuits. He is currently a Ph.D. student in Faculty of Electrical and Computer Engineering, University of Tabriz, Tabriz, Iran.