

Low Complexity Hybrid Scheme for PAPR Reduction in OFDM Systems Based on SLM and Clipping

V. Sudha, D. Sriram Kumar

Abstract—In this paper, we present a low complexity hybrid scheme using conventional selective mapping (C-SLM) and clipping algorithms to reduce the high peak-to-average power ratio (PAPR) of orthogonal frequency division multiplexing (OFDM) signal. In the proposed scheme, the input data sequence (X) is divided into two sub-blocks, then clipping algorithm is applied to the first sub-block, whereas C-SLM algorithm is applied to the second sub-block in order to reduce both computational complexity and PAPR. The resultant time domain OFDM signal is obtained by combining the output of two sub-blocks. The simulation results show that the proposed hybrid scheme provides 0.45 dB PAPR reduction gain at CCDF value of 10^{-2} and 52% of computational complexity reduction when compared to C-SLM scheme at the expense of slight degradation in bit error rate (BER) performance.

Keywords—CCDF, Clipping, OFDM, PAPR, SLM.

I. INTRODUCTION

OFDM is a method of encoding digital data over a large number of narrow band orthogonal sub-carriers (N). Each symbol modulates a separate sub-carrier frequency and these modulated sub-carrier frequencies are multiplexed. The bandwidth of each sub-carrier is less than the coherence bandwidth of the channel in order to reduce the multipath fading effects. The OFDM system is highly spectral efficient, robust to impulse interference and channel variations. Therefore, it has been used in many wireless standards such as digital audio broadcasting/digital video broadcasting (DAB/DVB), WLAN and also considered as an important candidate in 4G systems. However, the system performance is limited by PAPR of OFDM signal. This high peak occurs when all the sub-carriers add up constructively at the inverse fast Fourier transform (IFFT) block.

To reduce PAPR, a number of solutions are provided in the literature [1], [2] which include clipping [3], clipping and filtering [4]-[6], coding method i.e. Golay complementary sequences [7] and Reed Muller codes [8]. Other approaches include tone injection [9], tone reservation [10], modified Mu-law companding [11], active constellation extension [12] and multiple signaling techniques such as SLM [13]-[15], partial transmit sequence (PTS) [16]-[18] and so on. SLM and PTS

provide PAPR reduction without introducing distortion and SLM is most widely used method due to its simple structure. However, it suffers by more computational complexity.

Recently, hybrid schemes based on PTS and clipping [19], serial combination of SLM and clipping [20], clipping and SLM [21], [22], SLM and PTS [23] algorithms are applied to enhance the PAPR reduction performance of OFDM signal. However, these algorithms do not show any improvement in terms of computational complexity.

In this paper, to achieve both reduction in computational complexity and PAPR, a hybrid scheme comprising of the parallel combination of SLM and clipping algorithms is proposed, where the first half of the input data sequence is processed by nonlinear signal processing (clipping) algorithm and the second half of the input data sequence is processed by linear (SLM) algorithm. This method combines the advantages of both SLM and clipping algorithms. Simulation results demonstrate the effectiveness of the proposed scheme.

The rest of the paper is organized as follows. In Section II, the definition for PAPR of OFDM signal is given. Conventional clipping and SLM algorithms are discussed in Section III. In Section IV, the proposed hybrid scheme is presented. In Section V, computational complexity of the proposed scheme is analyzed. Simulation results are discussed in Section VI. Finally, in Section VII the concluding remarks are given.

II. PAPR OF OFDM SIGNAL

For one OFDM symbol with N number of sub-carriers, the continuous time OFDM signal can be expressed as

$$x(t) = \frac{1}{\sqrt{N}} \sum_{n=0}^{N-1} X(n) e^{j2\pi n \Delta f t}, \quad 0 \leq t \leq T \quad (1)$$

where $X(n)$ is the data symbol of n^{th} sub-carrier, Δf is the frequency spacing between the adjacent sub-carriers and T is one OFDM symbol duration.

The PAPR of OFDM signal is defined as the ratio of the instantaneous peak power to the average power. For the continuous time signal $x(t)$, it can be expressed as

$$PAPR = 10 \log_{10} \frac{\max_{0 \leq t \leq NT} |x(t)|^2}{P_{av}} \quad (2)$$

V. Sudha is with the Department of Electronics and Communication Engineering, National Institute of Technology, Tiruchirappalli, Tamilnadu, India (phone: 0431-2503319; e-mail: vsudha@nitt.edu).

D. Sriram Kumar is with the Department of Electronics and Communication Engineering, National Institute of Technology, Tiruchirappalli, Tamilnadu, India.

where P_{av} is the average power of the transmitted symbol.

In general, PAPR of a continuous time signal is not necessarily same as discrete time signal. However, it is closely approximated by over sampling the time domain signal with the factor $L=4$. The discrete time OFDM signal can be expressed as

$$x(n) = \frac{1}{\sqrt{N}} \sum_{k=0}^{N-1} X(k) e^{j2\pi k n/N}, 0 \leq n \leq N-1 \quad (3)$$

where

$$X(k) = [X(0), X(1), \dots, X(N-1)]^T$$

PAPR of discrete time signal is defined as

$$PAPR = 10 \log_{10} \frac{\max_{0 \leq n \leq N-1} |x(n)|^2}{P_{av}} \quad (4)$$

According to the central limit theorem, for the larger value of N , the real and imaginary parts of $x(n)$ follow a Gaussian distribution with zero mean and variance of 0.5. The amplitude of OFDM signal follows a Rayleigh distribution.

PAPR of OFDM signal is characterized by the complementary cumulative distribution function (CCDF), which is defined as the probability that the PAPR of OFDM signal exceeds a given threshold $PAPR_0$. CCDF of PAPR is given by

$$CCDF = \Pr(PAPR > PAPR_0) = 1 - (1 - e^{-PAPR_0})^N \quad (5)$$

PAPR value exponentially increases for large value of N .

III. EXISTING PAPR REDUCTION TECHNIQUES

A. C-SLM [2]

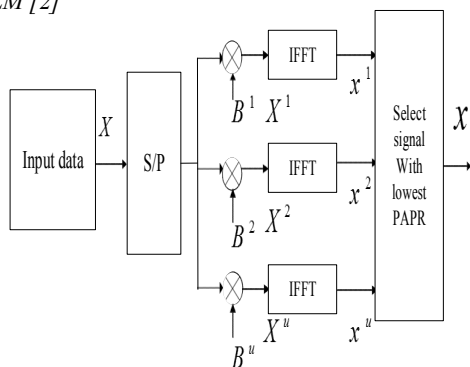

Fig. 1 Block diagram of C-SLM

In C-SLM, U statistically independent data sequences are generated from the input data sequence X by multiplying it with U unique random phase sequences and then PAPR is calculated for each data sequence. Among U data sequences,

one with minimum PAPR is selected for transmission as shown in Fig. 1.

The input data sequence X is expressed as an N dimensional vector i.e.

$$X = [X_0, X_1, \dots, X_{N-1}]^T \quad (6)$$

and the phase rotation vector is denoted as

$$B^u = [b_{u,0}, b_{u,1}, \dots, b_{u,N-1}]^T, 1 \leq u \leq U \quad (7)$$

As mentioned earlier, oversampling of each data sequence is essential for having a better approximation of the true PAPR and it can be done by inserting $(L-1)N$ zeros in the middle of the frequency domain input data sequence.

U candidates are generated by performing component-wise multiplication of the input sequence X with the phase rotation vector B^u and is given by

$$X^u = X \cdot B^u \quad (8)$$

$$X^u = [X_0 b_{u,0}, X_1 b_{u,1}, \dots, X_{LN-1} b_{u,LN-1}]^T, u = 1, 2, \dots, U \quad (9)$$

The elements in the phase vector consist of $\{1, -1, j, -j\}$ and each symbol in the phase vector has unit magnitude in order to preserve the power. The U time domain data sequences are generated by taking IFFTs of the frequency domain vector represented as (10)

$$x^u = \text{IFFT}(X^u) \quad (10)$$

$$x^u = \frac{1}{\sqrt{LN}} \sum_{n=0}^{LN-1} X_n \cdot b_{u,n} \cdot e^{j2\pi n \Delta f t}, 0 \leq n \leq LN-1, u = 1, 2, \dots, U \quad (11)$$

Among the U data sequences, one with lowest PAPR is selected for transmission and the corresponding phase sequence index is transmitted to the receiver as side information (SI) to recover the transmitted signal.

B. Clipping Algorithm

Let $x(n), n = 0, 1, \dots, LN-1$ denote the output of LN -point IFFT. Clipping method limits the peak amplitude of complex OFDM symbol $x(n)$ whenever it exceeds a certain threshold value (A), otherwise it allows the input signal for transmission as,

$$\overline{x(n)} = \begin{cases} x(n), & |x(n)| \leq A \\ A \cdot e^{j\phi(n)}, & |x(n)| > A \end{cases} \quad (12)$$

where $\phi(n)$ is the phase of the input signal, A is the maximum amplitude of the clipped signal.

Clipping of OFDM signal introduces out-of-band radiation and it can be minimized by filtering of clipped signal. Many

clipping methods have been proposed [24] namely *MIN* clipping, *ZERO* clipping, *MAX* clipping, suboptimal *MIN/MAX* clipping. Among them, suboptimal *MIN/MAX* clipping provides good amount of PAPR reduction.

IV. PROPOSED LOW COMPLEXITY HYBRID SCHEME

In [21], Byung Moo Lee et al., theoretically analyzed BER performance of clipping with SLM over flat and frequency selective fading channels and concluded that the combined scheme based on clipping with C-SLM can achieve a good amount of PAPR reduction. However, no change in computational complexity.

In [23], C-SLM is applied for half of the input data sequence, whereas C-PTS algorithm is applied for the remaining half of the input data sequence. Though, their method achieves PAPR reduction, computational complexity lies between C-SLM and C-PTS.

In this paper, to reduce computational complexity and retain implementation simplicity, clipping and C-SLM schemes are utilized simultaneously. Clipping is applied for the first half of the input data sequence (0 to N/2-1) and C-SLM for the remaining half of the input data sequence (N/2 to N-1) to construct the new candidate with minimum PAPR as shown in Fig. 2. Hence, the overall performance of proposed algorithms does not interfere with individual algorithm performance. In addition, PAPR reduction performance of the proposed hybrid scheme is analyzed for different input data segmentation namely adjacent segmentation and interleaving segmentation [25].

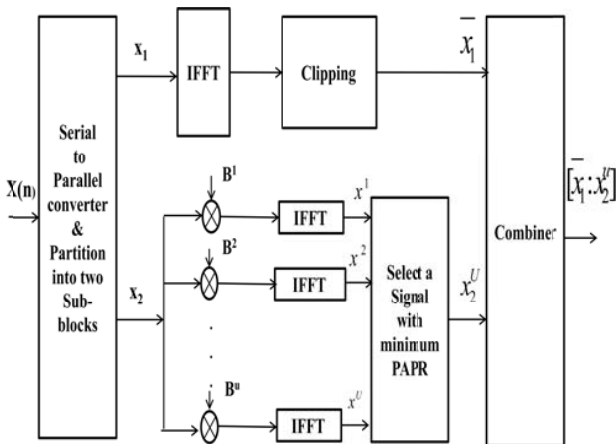

Fig. 2 The transmitter structure of proposed Hybrid Scheme

A. Algorithm 1 (Algorithm with Adjacent Segmentation)

Step 1: The input data sequence X is partitioned into two sub-blocks, namely X_1, X_2 and can be expressed as

$$X_1 = [X(0), X(1), \dots, X(N/2 - 1)]^T \quad (13)$$

$$X_2 = [X(N/2), X(N/2 + 1), \dots, X(N - 1)]^T \quad (14)$$

Step 2: $LN/2$ point IFFT is taken for the frequency domain input vector X_1 , then clipping algorithm is applied to the obtained time domain signal x_1 , by using (12) and the resultant signal is represented as \bar{x}_1 .

Step 3: Second sub-block data sequence X_2 is multiplied with the U number of phase sequences to generate U time domain vectors all representing the same information $x_2^u, (1 \leq u \leq U)$ by using (11). One candidate from U candidates with minimum PAPR is chosen for transmission.

Step 4: The resultant time domain OFDM signal with minimum PAPR is obtained by combining the first sub-block clipped signal \bar{x}_1 with a second sub-block candidate x_2^u as

$$x(n)' = [\bar{x}_1 : x_2^u] \quad (15)$$

B. Algorithm 2 (Algorithm with Interleaving Segmentation)

Step 1: The input data block X is partitioned into two sub-blocks, namely X_{odd}, X_{even} respectively. X_{odd} consists of odd indexed input symbols and X_{even} consists of even indexed input symbols denoted as

$$X_{odd} = [X(1), X(3), \dots, X(N-1)]^T \quad (16)$$

$$X_{even} = [X(0), X(2), \dots, X(N)]^T \quad (17)$$

Step 2: $LN/2$ point IFFT is taken for the input vector X_{odd} , then clipping algorithm is applied. The resultant time domain signal \bar{x}_{odd} is obtained by using (12).

Step 3: Generate U time domain vectors for the input vector X_{even} by using (11) and one candidate from U candidates is selected and combined with clipped signal as

$$x(n)' = [\bar{x}_{odd} : x_{even}^u] \quad (18)$$

V. ANALYSIS OF COMPUTATIONAL COMPLEXITY

In this section, computational complexity of the proposed hybrid scheme is analyzed and compared with C-SLM. In general, the total number of complex multiplications (N_{mul}) and additions (N_{add}) required for one LN point IFFT operation is given by

$$N_{mul} = (LN / 2) \log_2 LN \quad (19)$$

$$N_{add} = LN \log_2 LN \quad (20)$$

In C-SLM, U number of LN -Point IFFT blocks are required to generate U candidate signals. In the proposed scheme, since only half of the input sequence ($N/2$) is applied to the C-SLM

algorithm, it requires only the U number of $LN/2$ point IFFT blocks. Therefore, the total number of IFFT blocks required for the proposed method is $(U+1) LN/2$ and the total number of complex multiplications (N_{mul}) and additions (N_{add}) required for the proposed method are given by

$$N_{mul} = LN / 4 * \log_2 LN / 2 + ULN / 4 * \log_2 LN / 2 \quad (21)$$

$$N_{add} = LN / 2 * \log_2 LN / 2 + ULN / 2 * \log_2 LN / 2 \quad (22)$$

The computational complexity reduction ratio (CCRR) [16] of the proposed algorithm over C-SLM is defined as,

$$CCRR = \left(1 - \frac{\text{Complexity of Proposed algorithm}}{\text{Complexity of C-SLM}} \right) \times 100\% \quad (23)$$

TABLE I

 COMPUTATIONAL COMPLEXITY OF PROPOSED ALGORITHMS WITH C-SLM
 WHEN $N=256$

S. No	C-SLM	Proposed Algorithm	CCRR%
When $U=4$			
N_{mul}	20,480	11,520	43.75
N_{add}	40,960	23,040	43.75
When $U=16$			
N_{mul}	81,920	39,168	52.18
N_{add}	163,840	78,336	52.18
When $U=64$			
N_{mul}	327,680	149,760	54.29
N_{add}	655,360	299,520	54.29

The CCRR of the proposed algorithm over C-SLM is given in Table I. Here, we assumed that $N=256$ and $U=4, 16, 64$ respectively. When $U=16$, the CCRR of the proposed algorithms is 52% when compared to C-SLM.

VI. SIMULATION RESULTS AND DISCUSSION

The performance of the proposed algorithms is evaluated in terms of CCDF of PAPR, BER and computational complexity. For the purpose of simulation, 10000 randomly generated data symbols are modulated using Quadrature Amplitude Modulation (QAM) and the number of sub-carriers $N=256$, oversampling factor $L=4$ and the number of candidates $U=16$ are examined. The PAPR reduction performance of proposed algorithms 1 and 2 is analyzed through simulations.

Fig. 3 shows the CCDF comparison of the proposed algorithms 1 and 2 with respect to OFDM, clipping with clipping ratio $CR=1.4$ & 1.6 , C-SLM with $U=16$ and a hybrid scheme with the serial combination of SLM and clipping. The simulation result shows that the proposed algorithms 1 and 2 provide same PAPR reduction performance. The PAPR at $CCDF = 10^{-2}$ is improved by 0.25 dB, 0.45 dB than C-SLM for the clipping ratio (CR) 1.4 and 1.6 respectively, and is poorer than applying clipping alone and hybrid scheme with a serial combination of SLM and clipping.

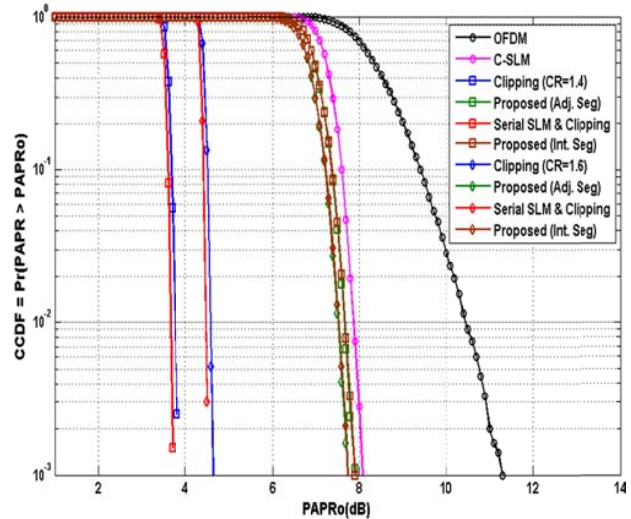
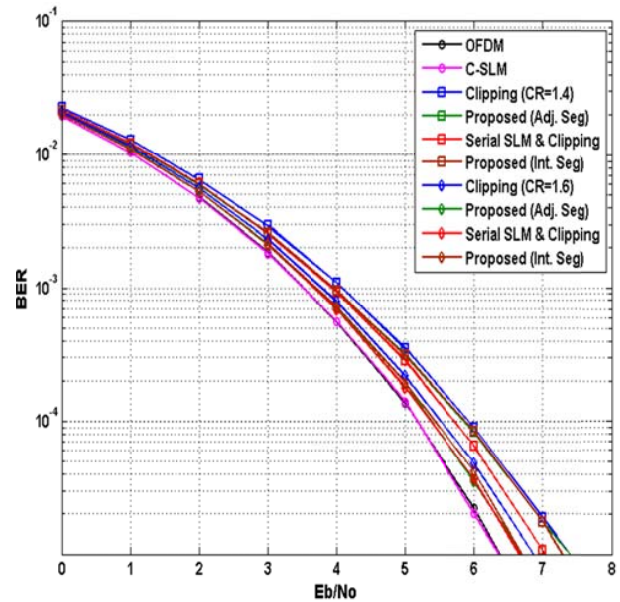

 Fig. 3 CCDF comparison of proposed hybrid scheme with conventional algorithms ($N=256$)

 Fig. 4 BER comparison of proposed hybrid scheme with conventional algorithms ($N=256$)

Fig. 4 shows the BER performance comparison of proposed algorithms with conventional algorithms over Additive White Gaussian Noise (AWGN) channel. The BER performance of the proposed algorithm slightly degrades with respect to OFDM, SLM and serial combination of SLM & clipping, but better than clipping as the clipping noise of the combined scheme would be less than the clipping technique is applied to the whole data.

VII. CONCLUSION

In this paper, we proposed a low complexity hybrid scheme based on clipping and SLM algorithms for PAPR reduction in OFDM systems. To reduce the computational complexity, both algorithms are applied simultaneously. Simulation results show that our algorithm achieves improved PAPR reduction performance than C-SLM using less number of IFFT blocks with slight degradation in BER performance. From the computational complexity analysis, the proposed hybrid scheme achieves almost 52% complexity reduction when compared to other hybrid schemes and C-SLM algorithm. Hence, the proposed hybrid scheme is promising to reduce PAPR of OFDM signal with much reduced complexity at the cost of slight degradation in BER performance.

REFERENCES

- [1] Han, SeungHee, and Jae Hong Lee. "An overview of peak-to-average power ratio reduction techniques for multicarrier transmission." IEEE Wireless Communications, (2005). 12(2), 56-65.
- [2] Hwang, Taewon, et al. OFDM and its wireless applications: a survey. IEEE Transactions on Vehicular Technology, (2009).58(4), 1673-1694.
- [3] Ochiai, Hideki, and Hideki Imai. Performance analysis of deliberately clipped OFDM signals. IEEE Transactions on Communications, (2002). 50(1), 89-101.
- [4] Li, Xiaodong, and Leonard J. Cimini Jr. Effects of clipping and filtering on the performance of OFDM. IEEE 47th Vehicular Technology Conference, (1997). Vol. 3.
- [5] Zhu, Xiaodong, et al. Simplified Approach to Optimized Iterative Clipping and Filtering for PAPR Reduction of OFDM Signals, IEEE Transactions on Communications. (2013). 61(5), 1891-1901.
- [6] Wang, Y., and Z. Luo. Optimized iterative clipping and filtering for PAPR reduction of OFDM signals. IEEE Transactions on Communications. (2011).59(1), 33-37.
- [7] Gil Jiménez, Víctor P., et al. "Efficient implementation of complementary Golay sequences for PAR reduction and forward error correction in OFDM-based WLAN systems." AEU-International Journal of Electronics and Communications 62.9 (2008): 683-694.
- [8] Davis, James A., and Jonathan Jedwab. "Peak-to-mean power control in OFDM, Golay complementary sequences, and Reed-Muller codes." Information Theory, IEEE Transactions on 45.7 (1999): 2397-2417.
- [9] Hou, Jun, ChinthaTellambura, and Jianhua Ge. "Tone injection for PAPR reduction using parallel tabu search algorithm in OFDM systems." Global Communications Conference (GLOBECOM) IEEE. IEEE, 2012.
- [10] Li, Haibo, Tao Jiang, and Yang Zhou. "An improved tone reservation scheme with fastconvergence for PAPR reduction in OFDM systems." Broadcasting, IEEE Transactions on 57.4 (2011): 902-906.
- [11] Vallavaraj, Athinarayanan, Brian G. Stewart, and David K. Harrison. "An evaluation of modified μ -Law companding to reduce the PAPR of OFDM systems." AEU-International Journal of Electronics and Communications 64.9 (2010): 844-857.
- [12] Krongold, Brian S., and Douglas L. Jones. "PAR reduction in OFDM via active constellation extension." Broadcasting, IEEE Transactions on 49.3(2003): 258-268.
- [13] Robert, Bauml, F. Robert, and B. H. Johannes. "Reducing the peak-to-average power ratio of multicarrier modulation by selected mapping." *Electron. lett* 32 (1996): 2056-2057.
- [14] Bae, Kitaek, Changyong Shin, and E. Powers. Performance Analysis of OFDM Systems with Selected Mapping in the Presence of Nonlinearity. IEEE Transactions on Wireless Communications, 12(5), (2013):2314-2322.
- [15] Yang, L., et al. "Low-complexity PAPR reduction technique for OFDM systems using modified widely linear SLM scheme." AEU-International Journal of Electronics and Communications 66.12 (2012): 1006-1010.
- [16] Cimini Jr, Leonard J., and Nelson R. Sollenberger. Peak-to-average power ratio reduction of an OFDM signal using partial transmit sequences. IEEE Communications Letters, 4(3), (2000): 86-88.
- [17] Varahram, Pooria, and BorhanuddinMohd Ali. Partial transmit sequence scheme with new phase sequence for PAPR reduction in OFDM systems." IEEE Transactions on Consumer Electronics, 57(2), (2011): 366-371.
- [18] Hou, Jun, Jianhua Ge, and Jing Li. Peak-to-average power ratio reduction of OFDM signals using PTS scheme with low computational complexity. IEEE Transactions on Broadcasting, 57(1), (2011):143-148.
- [19] Cuteanu, Eugen Victor, and Alexandrulsar. PAPR Reduction of OFDM Signals using Partial Transmit Sequence and Clipping Hybrid Scheme. AICT 2012, The Eighth Advanced International Conference on Telecommunications. (2012).
- [20] Victor Cuteanu, Alexandrulsar. PAPR reduction of OFDM signals using selective Mapping and clipping hybrid scheme. European signal processing conference, (2012): ISSN 2076-1465.
- [21] Lee, Byung Moo, Youngok Kim, and Rui JP de Figueiredo. Performance Analysis of the Clipping Scheme with SLM Technique for PAPR Reduction of OFDM Signals in Fading Channels. Wireless Personal Communications, 63(2). (2012):331-344.
- [22] Ochiai, Hideki, and Hideki Imai. Performance of the deliberate clipping with adaptive symbol selection for strictly band-limited OFDM systems. IEEE Journal on Selected Areas in Communications, 18(11), (2000): 2270-2277.
- [23] Chunjiang Duanmu, Hongtaochen. Reduction of the PAPR in OFDM systems by intelligently Applying both PTS and SLM algorithms. Wireless Personal Communications, 74, (2014): 849-863.
- [24] Gay M, Lampe A, Breiling M. A hybrid PAPR reduction scheme for OFDM using SLM with clipping at the transmitter, and sparse reconstruction at the receiver. In Systems, Signals & Devices (SSD), 2014 11th International Multi-Conference on 2014 Feb 11 (pp. 1-6). IEEE.
- [25] Sudha, V; Kumar, D. "Low Complexity Peak-to-Average Power Ratio Reduction in Orthogonal Frequency Division Multiplexing System by Simultaneously Applying Partial Transmit Sequence and Clipping Algorithms". World Academy of Science, Engineering and Technology, International Science Index 100, International Journal of Electrical, Computer, Energetic, Electronic and Communication Engineering, (2015), 9(4), 465 – 471.

V. Sudha received her BE degree in Electronics and Communication Engineering from Bharathidasan University, India in 2000 and the M.E degree in Communication Systems from Anna University, India in 2006. She is currently working as an Assistant Professor in the Department of ECE, National Institute of Technology (NIT), Tiruchirappalli, India. Her research interests include Digital Communication, Wireless communication, Wireless networks.

D. Sriram Kumar received his BE Degree in Electronics and Communication Engineering from Madurai Kamaraj University, India in 1991 and the Master of Engineering Degree in Microwave and Optical Engineering, from A.C. College of Engineering and Technology, Karaikudi, India, in 1994. He received the Ph.D. degree in Electronics and Communication Engineering from the Bharathidasan University, India, in 2009. He is currently working as an Associate Professor in the Department of Electronics and Communication Engineering, National Institute of Technology (NIT), Tiruchirappalli, India. His current research interests include Optical Networks, Smart Antennas, Optical Communications, and Microwave integrated circuits.