

# Design of Permanent Sensor Fault Tolerance Algorithms by Sliding Mode Observer for Smart Hybrid Powerpack

Sungsik Jo, Hyeonwoo Kim, Iksu Choi, Hunmo Kim

**Abstract**—In the SHP, LVDT sensor is for detecting the length changes of the EHA output, and the thrust of the EHA is controlled by the pressure sensor. Sensor is possible to cause hardware fault by internal problem or external disturbance. The EHA of SHP is able to be uncontrollable due to control by feedback from uncertain information, on this paper; the sliding mode observer algorithm estimates the original sensor output information in permanent sensor fault. The proposed algorithm shows performance to recovery fault of disconnection and short circuit basically, also the algorithm detect various of sensor fault mode.

**Keywords**—Smart Hybrid Powerpack (SHP), Electro Hydraulic Actuator (EHA), Permanent Sensor fault tolerance, Sliding mode observer (SMO), Graphic User Interface (GUI).

## I. INTRODUCTION

HYDRAULIC system of modern industry requires higher precise and accurate performance. It is possible to indicate the demand by configuration between feedback control and sensor. To reduce the impact of system external disturbance factors, robust control theory is applied [1]-[4]. In addition, the hydraulic system is required to improve spatiality and energy efficiency, to be oriented environment of remote control and monitoring for automatic control [2]. As a quality function deployment, the electro-hydraulic actuator (EHA) is considered higher energy efficiency to control the cylinder by two-way rotary pump with electric servo motor in place of the valve. Through this view, Smart hybrid powerpack(SHP) is developed as shown in Fig. 1 [6].

SHP is the control and monitoring system for the EHA. It has been applied intelligent control for safety and reliability of the system, and monitoring functions remote control, variety of sensors for control of precise and accurate as in Fig. 2 [6].

About sensors in the SHP, it uses LVDT(Linear Variable Differential Transformer) to detect a change in the length of the cylinder output, and pressure sensor to control the thrust by sensing the pressure in the system. LVDT is built in the cylinder rod, and the pressure sensor is attached to input and output port of the cylinder head part. The EHA which is compact is provided minimal number of sensor, as a LVDT sensor that is used solely to control of cylinder position. If a fault occurs in sensor, the cylinder is difficult to control due to

the uncertain information. In case of temporary noise by electrical cause, the noise is recovered by hardware method as coil filter, or by software method as Kalman filter [6]. If the permanent sensor failure occur as hardware fault on the generated sensor, it needs to recover quickly, in order to lead to serious problems to the control. To prevent this situation, on this paper, the sliding mode observer estimates the original sensor output information in permanent sensor fault. All of simulation was done by MATLAB Simulink and also was seen in Graphic User Interface(GUI) by LabVIEW [8].

This paper is organized into 4 sections including this introduction. Section 2 of the sliding mode observer algorithm analysis and describes the type of the sensor failure. In section 3, interpretation of the algorithm and the sliding mode observer show for the type of sensor failure. Finally the conclusion is expressed as in Section 4.

## II. DESIGN OF ALGORITHM BASED ON SLIDING MODE OBSERVER FOR PERMANENT SENSOR FAULT TOLERANCE

To control position output of cylinder in SHP, it needs to show real internal pressure and position of cylinder rod in EHA. About LVDT sensor, if a permanent failure has occurred, it cannot be cylinder speed control, also it is not possible to detect the exact position of the cylinder rod output. If the fault occurs in pressure sensor, the system cannot detect the required information of internal pressure to control precise thrust of cylinder rod. It is based on the automatic control for SHP, if the sensor failure occurs, it may be possible to give a fatal effect on the system, and also working disaster occurs to human user. Therefore, the sensor failure must be quickly restored by appropriate software methods. To recovery permanent fault at LVDT and pressure sensor, in this paper, the real thrust output of SHP as cylinder rod is estimated by SMO algorithm. In order to estimate followed LVDT sensor and pressure sensor output value, the system model and the system input by discharge flow rate of pump must be known. The discharge flow rate dynamic equation is expressed as in (1) [4], [7].

$$Q = A\dot{y} + \frac{(V_H + Ay)\dot{P}}{\beta_e} \quad (1)$$

where, Q is the discharge flow rate of pump, A is a cross section area in the cylinder header, y is the cylinder rod position,  $\dot{y}$  is the cylinder rod velocity,  $V_H$  is the volume of cylinder header,  $\beta_e$  is bulk modulus of hydraulic fluid, P is the in-flow out-flow pressure of cylinder, and  $\dot{P}$  is the rate of change of pressure. Using a variation of the entered flow rate, the SMO estimates the signal from the pressure sensor and the LVDT that must be

Sungsik Jo is with the Department of Mechatronics Engineering, Sungkyunkwan University, South Korea (e-mail: jss815@naver.com)

Hyeonwoo Kim and Iksu Choi are with the Department of Mechanical Engineering, Sungkyunkwan University, South Korea (e-mail: jamesk88@nate.com, cis326@naver.com)

Hunmo Kim is with the Department of Mechanical Engineering, Sungkyunkwan University, South Korea (corresponding author; phone: 82-31-290-7450; fax: 82-31-290-7666; e-mail: kimhm@me.skku.ac.kr).

repaired by using a dynamic model of the cylinder. The sliding mode observer equations for LVDT and pressure sensor are expressed as follows (2) and (3) [3].

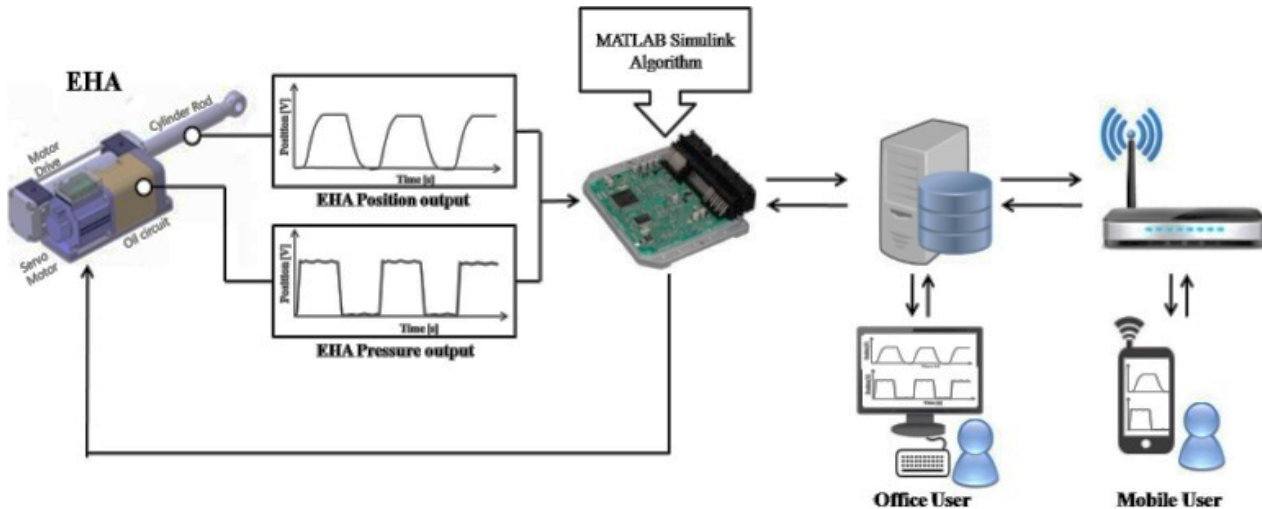

Fig. 1 The SHP system structure

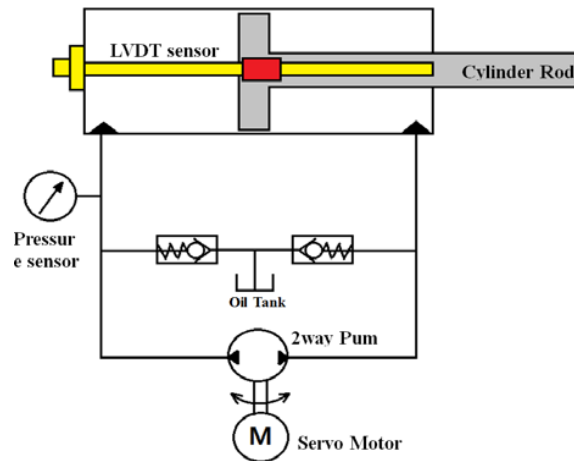

Fig. 2 The EHA structure

$$\hat{y} = -y + \frac{\beta_e}{A_H P} Q + k_1 \text{sgn}(\hat{y} - y) \quad (2)$$

$$\hat{P} = \frac{\beta_e}{V_H + A_H \hat{y}} (Q - A_H \hat{y}) + k_2 \text{sgn}(\hat{P} - P) \quad (3)$$

where,  $A_H$  is a cross section area in the cylinder header,  $\hat{y}$  is estimated position of cylinder rod,  $\dot{\hat{y}}$  is estimated velocity of cylinder rod,  $\hat{P}$  is estimated pressure value of EHA,  $\dot{\hat{P}}$  is estimated rate of change of pressure, and  $k_1$  and  $k_2$  are weight constant of  $\text{sgn}(\text{signum})$  function. In the (2) and (3), the SMO algorithm has characteristics vibration between the estimated value and the output value of the sensor to track the sensor signal source by signum function [5], [7].

### III. PERFORMANCE EVALUATION OF THE SLIDING MODE OBSERVER ALGORITHM FOR PERMANENT SENSOR FAULT MODE

This section evaluates the performance of the sliding mode observer with implementation details for software simulation.

Commonly permanent sensor fault modes are classified by 4 types in Table I. In the case of breaking of wire or short-circuit, sensor output is 0V. In the fixation case, which signal is fixed. Also in the case of drift, sensitive is changed or offset is changed.

TABLE I  
THE CLASSIFICATION OF SENSOR FAULT MODES

Class	Definition	Mode	Effect
Sensor failure	Permanent fault	Breaking of wire	Output Voltage 0V
		Short circuit	
		Fixation	Fixed voltage output
		Zero-drift	Offset change
		Sensitive-drift	Wrong rate of change

First, the simulation is considered about the permanent failure of the LVDT. The cylinder rod of the EHA is repeating output of rising and falling as show normal position-time curve

in Fig. 3.

The rising output is that the cylinder rode moves to out of the cylinder room until 0.5 seconds, on the other hand, the falling output is to move into inside of cylinder room for the time from 1 to 1.5 seconds in Fig. 3.

As in Fig. 4, it shows the SMO algorithm of LVDT sensor by using from MATLAB Simulink function blocks.

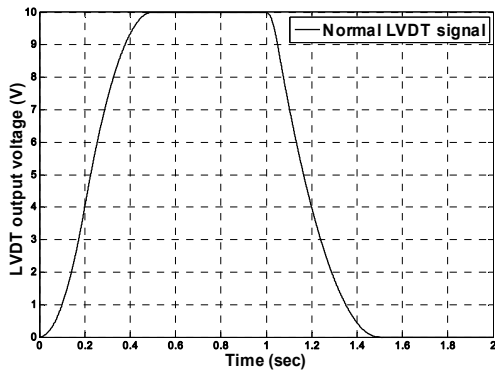

Fig. 3 Normal signal of LVDT

The model expresses permanent fault of the LVDT sensor simulation in consideration of the recovery in the SHP.

LVDT SMO is assumed to break short-circuit fault mode basically. The simulation results using the flow rate of pump, the algorithm estimates LVDT output within the error 0.275V max. To know the normal error rate the LVDT SMO, Fig. 5 is a graph about comparing between the LVDT SMO output values and LVDT output of a normal signal is shown in Fig. 5.

In Fig. 6, the signal shows the result of estimating normal signal up to 0.275V error. If it is determined in the fault mode of any of the four LVDT sensor exceeds the allowable range 0.275V, SHP is replaced by the estimate of the LVDT SMO.

The simulation of LVDT is shown by 4 types of permanent sensor fault mode. The result shows the comparison between short circuit/ braking of wire fault signal and recovered signal using LVDT SMO as in Fig. 8. When the signal is over the allowable range 0.275V from 0.05 to 1.4 seconds, the LVDT SMO replace to recovered signal. After that, the alarm outputs 1V as shown in Fig. 9.

In the Fig. 7, the signal represents to recovery from a sensor failure by alarm. The alarm outputs 1V or 0V, in case the sensor failure, the signal is 1V.

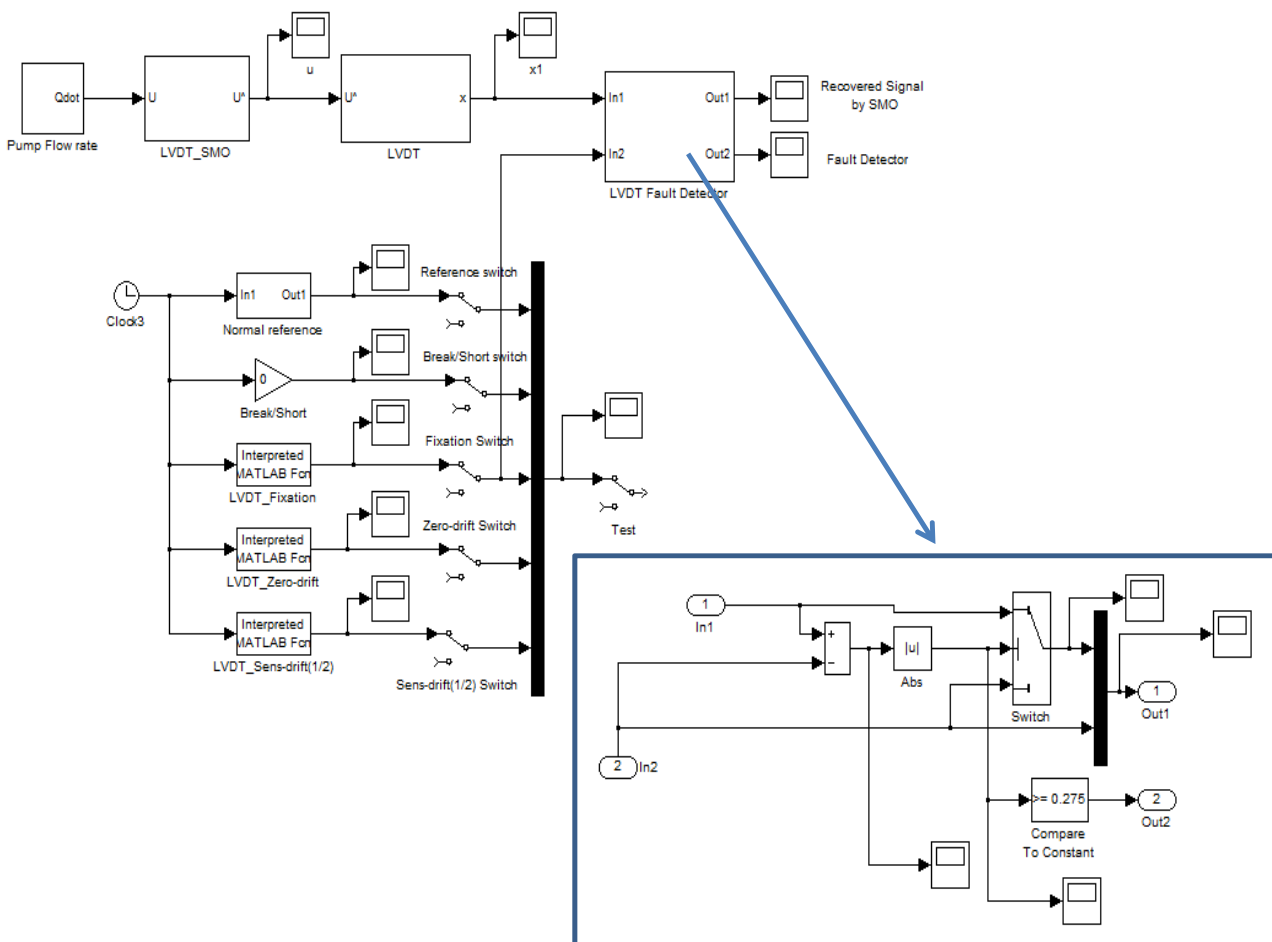

Fig. 4 MATLAB Simulink model of LVDT SMO

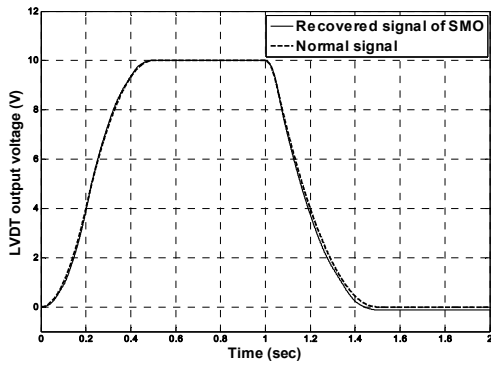

Fig. 5 Comparison between normal and SMO signal of LVDT

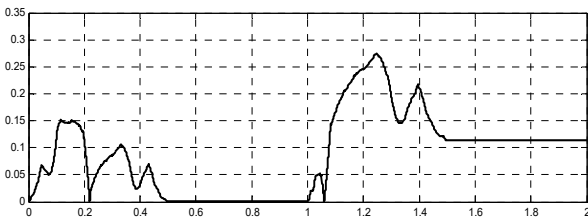

Fig. 6 Comparison between normal and SMO signal of LVDT

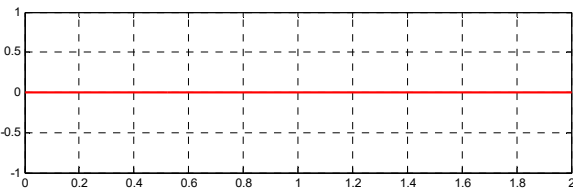

Fig. 7 Alarm signal about normal LVDT output

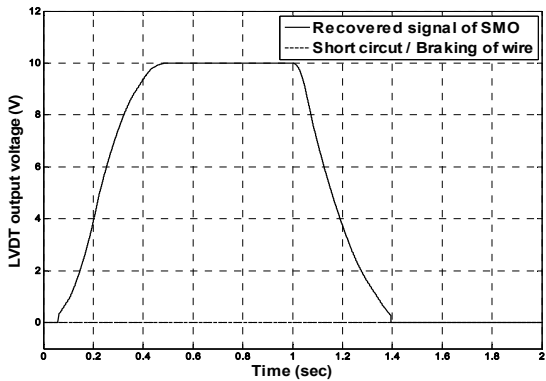

Fig. 8 Short circuit / Breaking of wire fault signal and recovered signal using SMO

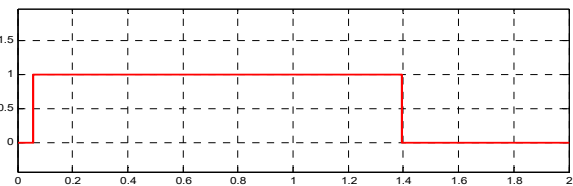

Fig. 9 Alarm signal about short circuit / Braking of wire fault

In the Fig. 10, the result shows a comparison of the SMO estimates the output value from the sensitive-drift and fixation complex faults. When the sensitive-drift fault from 0 to 0.4 seconds and the fixation fault from 1 second occur, the LVDT SMO replace to recovered signal with the alarm 1V output as shown in Fig. 11.

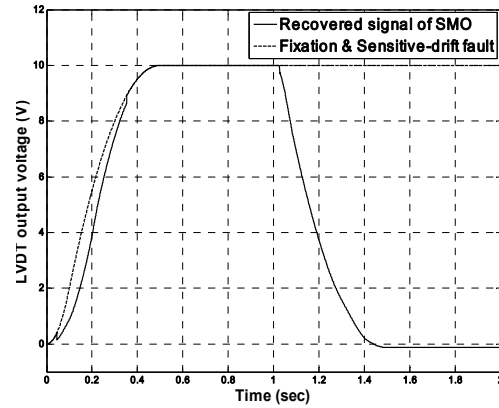

Fig. 10 Fixation & Sensitive-drift fault signal and recovered signal using SMO

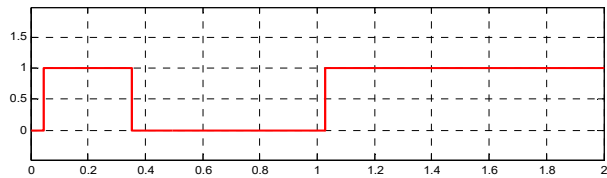

Fig. 11 Alarm signal about Fixation & Sensitive-drift fault

In the Fig. 12, the result shows the estimate output using LVDT SMO when the zero-drift fault is occurred. The LVDT SMO signal is replaced from all portions, because of the zero-drift fault is over allowable range on whole operation time. Also the alarm outputs from 0 to 2 seconds as shown in Fig. 13.

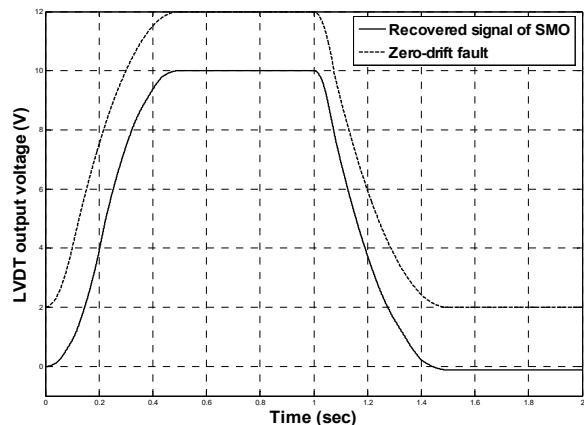

Fig. 12 Zero-drift fault signal and recovered signal using SMO

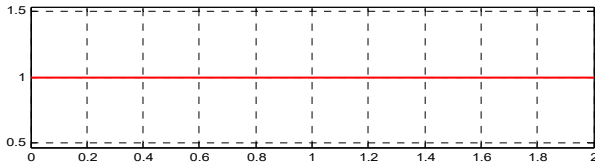

Fig. 13 Alarm signal about Zero-drift fault

In the Fig. 14, it shows the result about the sensitive-drift fault mode, the LVDT SMO compares between Sensitive-drift fault signal and estimated signal. For portion over allowable range 0.275V, the LVDT SMO is operated to recovery fault with alarm output is 1V as shown Fig. 15.

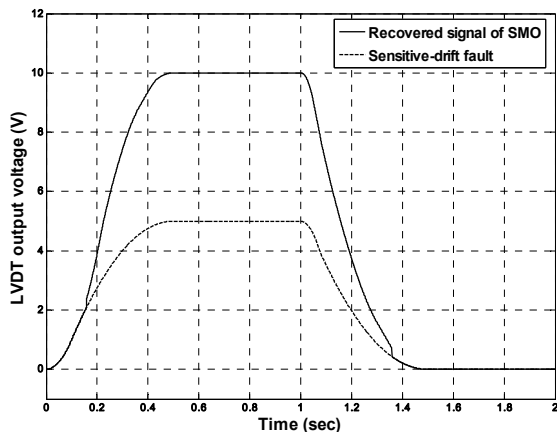

Fig. 14 Sensitive-drift fault signal and recovered signal using SMO

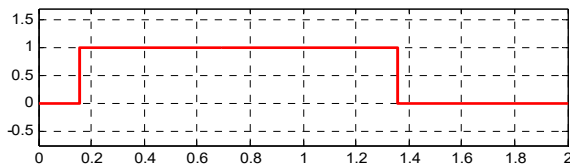

Fig. 15 Alarm signal about Sensitive-drift fault

Second, the simulation is considered for the permanent failure of the pressure sensor. In case of pressure sensor, the permanent sensor fault modes are also classified by 4 types as short circuit / Braking of wire, Fixation, and Zero / Sensitive drift fault. As in Fig. 16, normal signal is expressed. The cylinder rod of the EHA is repeating output of rising and falling as show normal position-time curve. The rising output is that the cylinder rode moves to out of the cylinder room until 0.5 seconds, on the other hand, the falling output is to move into inside of cylinder room for the time from 1 to 1.5 seconds.

In the Fig. 17, the pressure sensor SMO algorithm model is shown by using MATLAB Simulink. Pressure SMO is also assumed to break short-circuit fault mode basically as LVDT SMO.

In Fig. 17, the simulation results using the flow rate of pump, the algorithm estimates pressure output within the error 1.5V maximum. To know the normal error rate the pressure SMO, Fig. 17 is a graph about comparing between the pressure SMO

output values and pressure output of a normal waveform in the Fig. 18.

Fig. 18 shows the result of estimate up to 1.5V error less than the normal signal. In the interval slope (0sec to 0.1sec, 1sec to 1.1sec), The error rate result of the pressure SMO is large value due to the influence of chattering by the signum function of the Sliding mode algorithm. However, the average error rate is within the allowable performance. If it is determined in the fault 4 modes of pressure sensor exceeds the allowable range 1.5, SHP is replaced by the estimate of the SMO signal in Fig. 19.

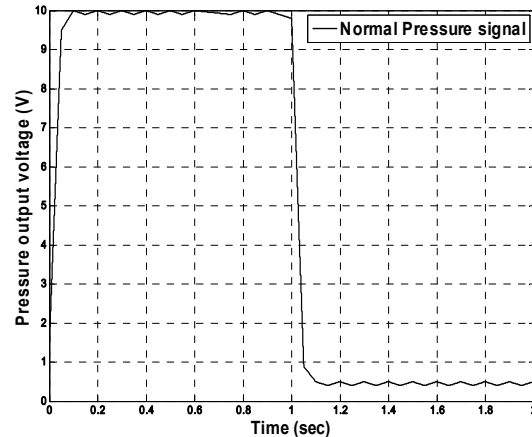

Fig. 16 Normal signal of Pressure sensor

If it is determined in the fault mode of any pressure sensor exceeds the allowable range 1.5V, SHP is replaced by the estimate of the pressure SMO with that the signal represents to recovery from the sensor failure by alarm as shown Fig. 20.

In the Fig. 21, the figure shows the Comparison between Short circuit/ Braking of wire fault signal and recovered signal using Pressure sensor SMO. When the signal is over the allowable range 1.5V from 0 to 1.4 seconds, the Pressure sensor SMO replace to recovered signal. After that, the alarm outputs 1V as shown by Fig. 22.

In the Fig. 23, the result shows that the SMO estimates the normal value from fixation fault. When the fixation fault from 0.03 seconds occurs, the pressure sensor SMO replaces to recovered signal with the alarm 1V output as shown Fig. 24.

The pressure SMO signal is replaced from all portions, because of the zero-drift fault is over allowable range 1.5V on whole operation in Fig. 25. Also the alarm output from 0 second as shown in Fig. 26.

In the Fig. 27, the figure shows the result about the sensitive-drift fault mode, the pressure SMO compares between sensitive-drift fault signal and estimated signal. For portion over allowable range 1.5V, the pressure SMO is operated to recovery fault with alarm output is 1V as shown Fig. 28.

These simulation results are also checked in Figs. 29 and 30 using GUI. Fig. 29 indicates the normal sensor signal when there is not fault. Original sensor signal is gotten on the left side plot of GUI and the fault alarm buttons are off. Meanwhile, in Fig. 30, there is fault and the fault alarm buttons are on. In this

case, recovered sensor signal by our logic is gotten on the right side plot of GUI. Whether algorithm is working can be

confirmed by Figs. 29 and 30 once our logic is applied to real system.

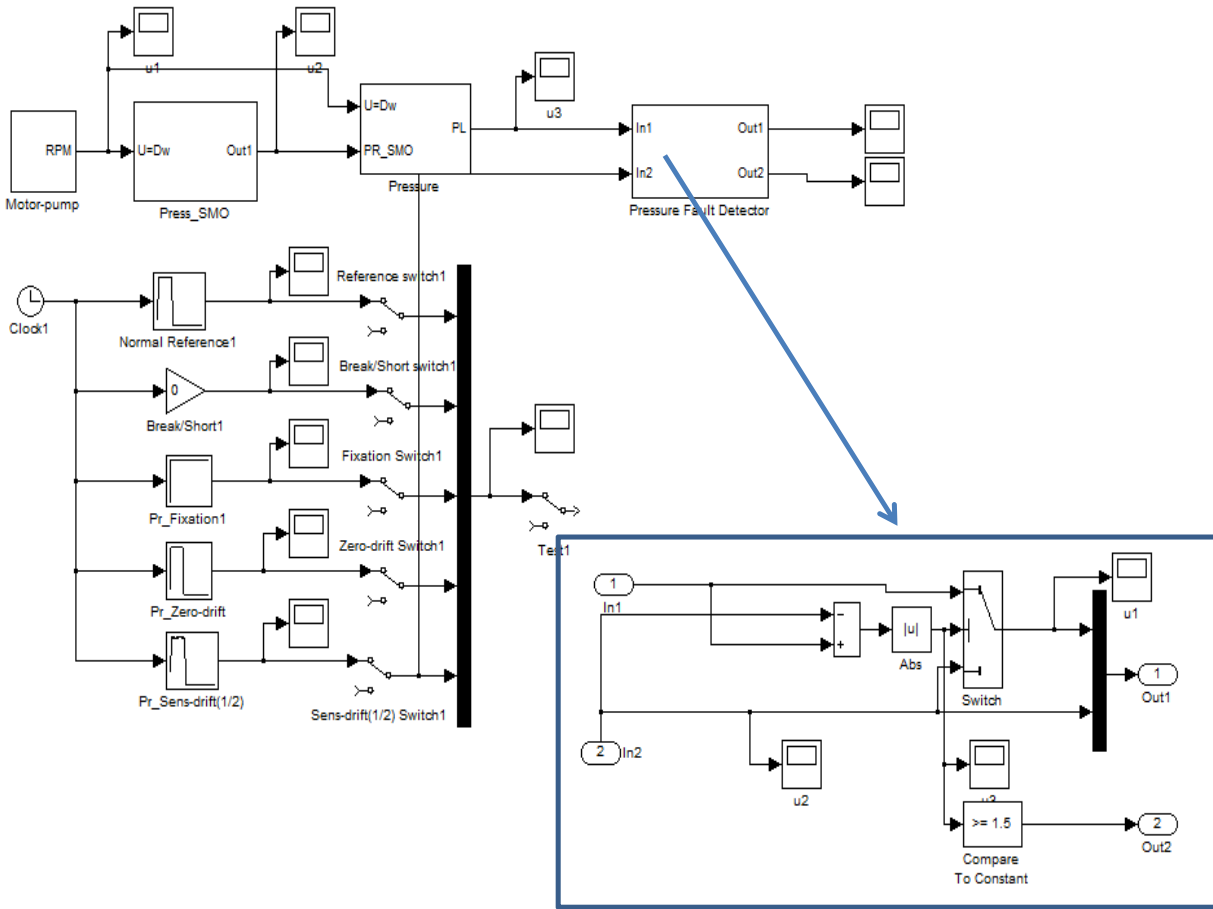

Fig. 17 MATLAB Simulink model of Pressure SMO

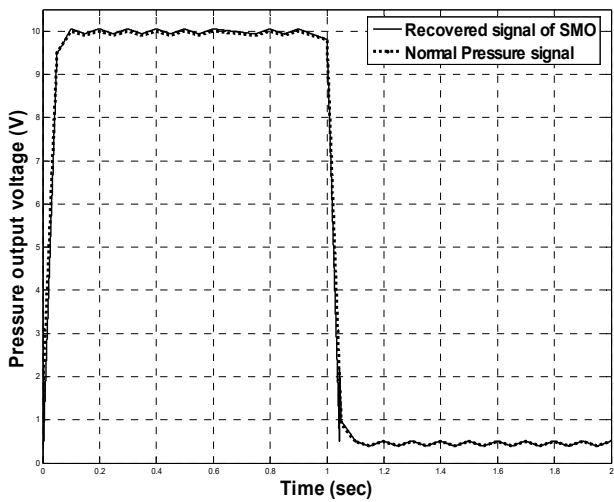

Fig. 18 Comparison between normal and SMO signal of Pressure

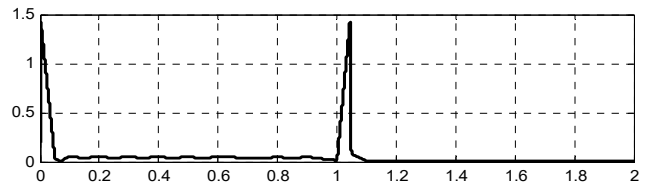

Fig. 19 Comparison between normal and SMO signal of LVDT

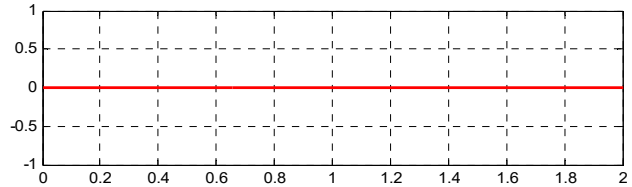

Fig. 20 Alarm signal about normal Pressure sensor output

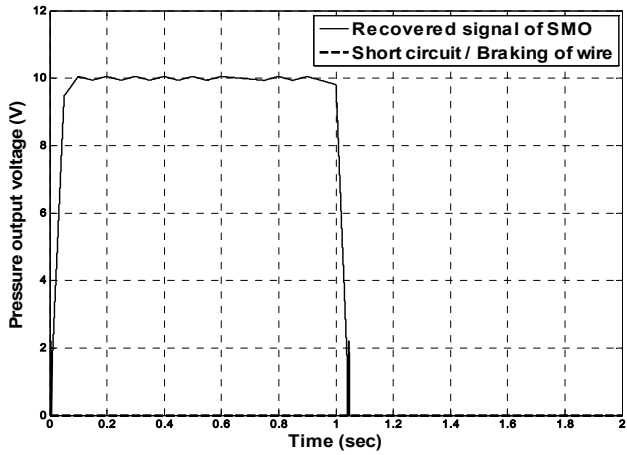

Fig. 21 Short circuit / Braking of wire fault signal and recovered signal using SMO

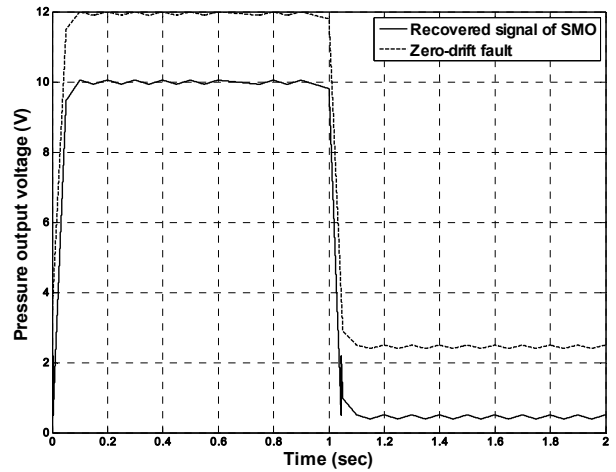

Fig. 25 Zero-drift fault signal and recovered signal using SMO

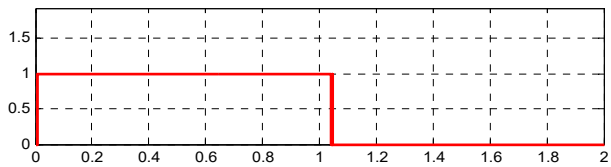

Fig. 22 Alarm signal about short circuit / Braking of wire fault

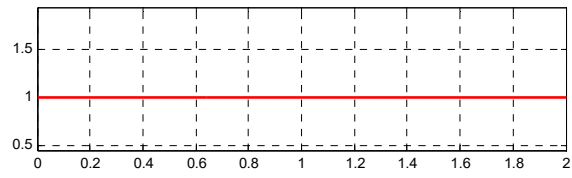

Fig. 26 Alarm signal about Zero-drift fault

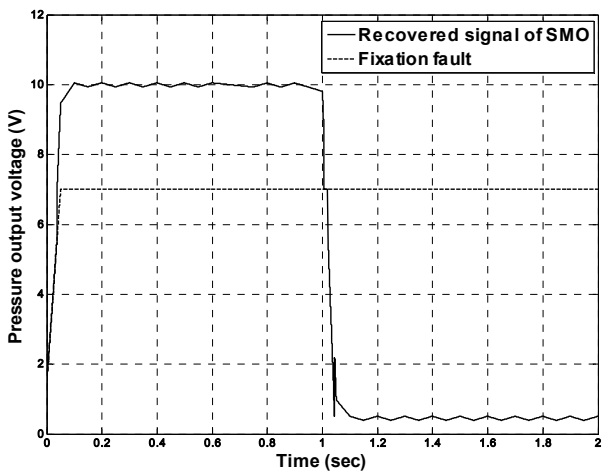

Fig. 23 Fixation fault signal and recovered signal using SMO

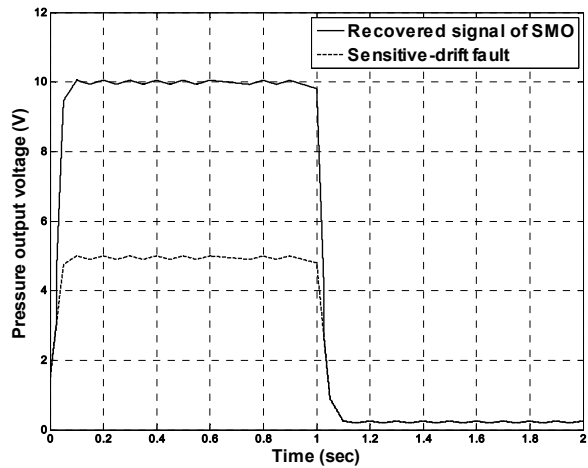

Fig. 27 Sensitive-drift fault signal and recovered signal using SMO

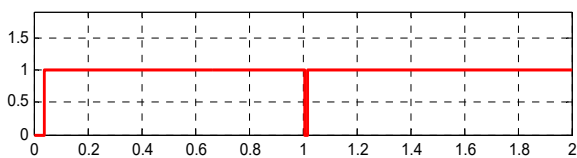

Fig. 24 Alarm signal about Fixation fault

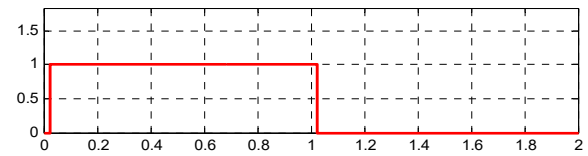

Fig. 28 Alarm signal about Sensitive-drift fault

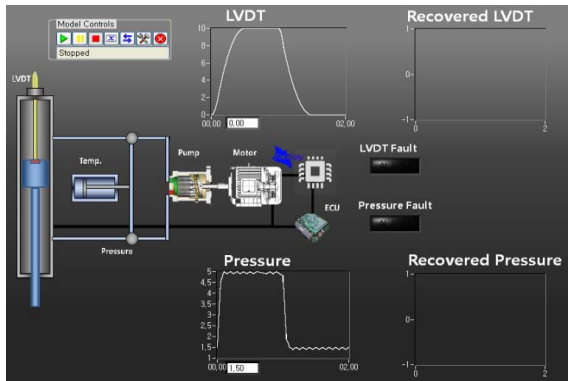

Fig. 29 Normal sensor signal on GUI

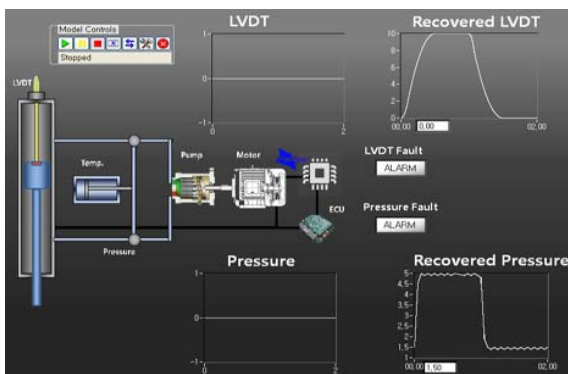

Fig. 30 Recovered sensor signal and alarm on GUI

#### IV. CONCLUSION

The purpose of this paper, precise sensing is required for the control of EHA. Thus, the accuracy of the sensor information is required. The information is accurate pressure sensor and LVDT sensor that generates permanent fault mode to overcome the fault-tolerant design technique was confirmed performance using MATLAB Simulink. Designed fault tolerant algorithms are confirmed performance for permanent various fault modes from LVDT and pressure sensor using MATLAB Simulation.

The SMO recover permanent sensor fault with respect to 4 critical fault mode at the time of diagnosis and follow-up of the original signal, as a result of the recovery is replaced.

In future, the SMO algorithms are making validate through the hardware simulator experience.

#### ACKNOWLEDGMENT

This work was supported by the SW Fusion Component Development of the KEIT grant funded by the Korea government Ministry of Trade, Industry & Energy.

#### REFERENCES

- [1] E. Sampson, S. R. Habibi, Y. Chinniah, R. Burton, 2005, "Model identification of the electrohydraulic actuator for small signal inputs", In Bath workshop on power transmission and motion control (PTMC 2005), 18th. University of Bath, United Kingdom.
- [2] S. R. Habibi, A. Goldenberg, 1999, "A Mechatronics Approach for the Design of a New High Performance Electro Hydraulic Actuator", International Off-Highway & Powerplant Congress & Exposition

Indianapolis, Indiana.

- [3] J. J. E. Slotine, J. K. Hedrick, and E. A. Misawa, "On sliding observers for nonlinear systems," in American Control Conference, 1986, 1986, pp.1794-1800.
- [4] S. H. Park, J. M. Lee, J. S. Kim, 2009, "Robust control of the pressure in a control-cylinder with direct drive valve for the variable displacement axial piston pump", Pro. Of IMechE, Part I: Journal of Systems and Control Engineering, vol. 223, no. 4.
- [5] C Guan, S Pan., "Adaptive sliding mode control of electro-hydraulic system with nonlinear unknown parameters", Cont. Eng. Prac., Vol. 16, No. 11, pp. 1275-84, 2008.
- [6] S. S. Jo, J. K. Choi, and H. M. Kim, "A Comparison between Kalman Filter and Threshold Predictor for Correcting Sensor Noise of Smart Hybrid Powerpack" pp. 166-173 , IRCITCS 2013, Sep. 28-30, 2013, Kuala Lumpur, Malaysia.
- [7] J. M. Lee, H. M. Kim, S. H. Park, and J. S. Kim, "A position control of electro-hydraulic actuator systems using the adaptive control scheme" proceeding of the 7<sup>th</sup> asian control conference, hong kong, china, august 27-29,2009
- [8] J. Choi, L. Shi, L. Wu, H. Kim, I. Choi and H. Kim, "Design of Self-tuning Fuzzy Control and Fault Tolerant Error Control Coding Based on Graphic User Interface for Smart Hybrid Powerpack", ICMM 2014, May 9-11, 2014, Xi'an, Shanxi, China.

**Sungsik Jo** received the B.S. in Mechanical Engineering from Wonkwang University, Korea, in 2010. He is a graduate student in department of Mechatronics Engineering, Sungkyunkwan University, Korea and works in control lab focused on the sensor fault tolerance algorithm of the smart hybrid Powerpack system.

**Hyeonwoo Kim** received the B.S. in Mechanical Engineering from Sungkyunkwan University, Korea, in 2013. He is a graduate student in department of mechanical engineering, Sungkyunkwan University, Korea and works in control lab focused on the GUI monitoring and control system for the smart hybrid Powerpack system.

**Iksu Choi** received the B.S. in Mechanical Engineering from Sungkyunkwan University, Korea, in 2013. He is a graduate student in department of mechanical engineering, Sungkyunkwan University, Korea and works in control lab focused on the GUI monitoring and control system for the smart hybrid Powerpack system.

**Hunmo Kim** received B.S. in Mechanical Engineering from Sungkyunkwan University, Korea, in 1984. He then received his M.S. degree of Aerospace Engineering from University of Michigan, U.S.A.1990. He then received Ph.D. degree in Mechanical Engineering from University of Alabama, U.S.A.1993. He is a professor in the Department of Mechanical Engineering at Sungkyunkwan University