

Seismic Assessment of an Existing Dual System RC Buildings in Madinah City

Tarek M. Alguhane, Ayman H. Khalil, M. N. Fayed, Ayman M. Ismail

Abstract—A 15-storey RC building, studied in this paper, is representative of modern building type constructed in Madina City in Saudi Arabia before 10 years ago. These buildings are almost consisting of reinforced concrete skeleton i.e. columns, beams and flat slab as well as shear walls in the stairs and elevator areas arranged in the way to have a resistance system for lateral loads (wind – earthquake loads). In this study, the dynamic properties of the 15-storey RC building were identified using ambient motions recorded at several, spatially-distributed locations within each building. Three dimensional pushover analysis (Nonlinear static analysis) was carried out using SAP2000 software incorporating inelastic material properties for concrete, infill and steel. The effect of modeling the building with and without infill walls, on the performance point as well as capacity and demand spectra due to EQ design spectrum function in Madina area has been investigated. ATC-40 capacity and demand spectra are utilized to get the modification factor (R) for the studied building. The purpose of this analysis is to evaluate the expected performance of structural systems by estimating, strength and deformation demands in design, and comparing these demands to available capacities at the performance levels of interest. The results are summarized and discussed.

Keywords—Seismic assessment, pushover analysis, ambient vibration, modal update.

I. INTRODUCTION

THE Western region of Saudi Arabia lies in low to moderate seismicity regions and seismic events of magnitude 5.7 were recorded in 2009 in areas near the holy city of Madinah, [1]-[3]. Majority of the structures built in Saudi Arabia in the seismically active western region are designed primarily for combination of gravity and wind loads with no consideration of seismic loading. Non-ductile detailing practice employed in these structures makes them prone to potential damage and failure during earthquake. Therefore, analysis of such buildings is required to gain insight of these seismic performances.

Modal identification of existing buildings through the analysis of in-situ vibration measurements became a classic procedure for providing modal characteristics of a building, for studying the seismic response of buildings and even for damage detection. Modal characteristics are often identified from ambient vibration measurements (AVM) and from

seismic records. Ambient vibration measurement is generally preferred to non-destructive forced vibration measurement techniques for obtaining the modal parameters of large structures for many reasons. A structure can be adequately excited by wind, traffic, and human activities and the resulting motions can be readily measured with highly sensitive instruments. Expensive and cumbersome devices to excite the structure are therefore not needed. Consequently, the overall cost of the measurements conducted on a large structure is reduced.

Ambient vibration measurements of many buildings have been recorded across the world in the past to determine their dynamic properties, in particular, to ascertain the properties of the fundamental modes of vibration, [4]-[7]. It is also recognized that the experimental data from one region may not be used in another owing to the differences in the construction methods and materials. References [8] and [9] showed that ambient vibration-based techniques were as accurate as active methods for determining vibration modes and much easier to implement for a large set of buildings.

A pushover analysis is performed by subjecting a structure to a monotonically increasing pattern of lateral loads, representing the inertial forces which would be experienced by the structure when subjected to ground shaking. Under incrementally increasing loads various structural elements may yield sequentially. Consequently, at each event, the structure experiences a loss in stiffness. Using a pushover analysis, a characteristic nonlinear force displacement relationship can be determined.

To estimate seismic demands in the design and evaluation of buildings, the nonlinear static procedures using the lateral force distributions recommended in ATC-40 [10] and the FEMA-356 [11] documents are now standard in engineering practice. The nonlinear static procedure in these documents is based on the capacity spectrum method (ATC-40) and displacement coefficient method (FEMA-356). It assumes that the lateral force distribution for the pushover analysis and the conversion of the results to the capacity diagram are based on the fundamental vibration mode of the elastic structure.

With the increase in the number of alternative pushover analysis procedure proposed in recent years, it is useful to assess the accuracy and classify the potential limitations of these methods. An assessment on accuracy of modal pushover analysis MPA and FEMA pushover analyses for moment resisting frame buildings was investigated by [12]-[16]. Then, an investigation on the accuracy of improved nonlinear static procedures in FEMA-440 [17] was carried out by [18]. Meanwhile, the ability of FEMA-356, MPA, and AMC in

Tarek M. Alguhane is Doctor of structural, King Abdullah WAQF, KSA (phone: 00966505375200; e-mail: tarijuha@hotmail.com).

Ayman Hussin is Professor of Structural Engineering, Ain Shams University, Egypt (e-mail: ayman_hh_khalil@yahoo.com).

M. N. Fayed is Professor of Structural Engineering, King Saud University, KSA (e-mail: mnourf@yahoo.com).

Ayman M. Ismail is Professor of Structural Engineering, HBRC, Egypt, (e-mail: ayman.m.ismail@gmail.com).

estimating seismic demands of a set of existing steel and reinforced concrete buildings was examined by [19]. More recently, an investigation into the effects of nonlinear static analysis procedures which are the Displacement Coefficient Method recommended in FEMA- 356 and the Capacity Spectrum Method recommended in ATC- 40 to performance evaluation on low-rise RC buildings was carried out by [20].

In this paper, an existing fifteen-storey reinforced concrete dual system building in Madinah City has been seismically evaluated with and without infill wall and their dynamic characteristic are compared with measured values in the field. After, updated the mathematical models for the building using field measurement of building's dynamic properties by using ambient vibration techniques, 3D pushover analysis has been carried out. The hinge status at target displacement, capacity diagram and the demand diagram for these studied buildings are investigated using two different structural models. These models are: Model I (frame elements without infill wall) and Model II (frame elements with infill wall as strut elements). The response modification factor (R) for the 15 story RC building is evaluated from capacity and demand spectra (ATC-40).

II. FEATURES OF THE BUILDING

The structure is an existing fifteen-storey reinforced concrete dual system building in Madinah City. The building is characterized by a combination of shear walls and frames in both directions. The building is used as a hotel. The location of the building and plan of a typical story above basement are shown in Figs. 1-4. Fig. 5 shows plan and elevation for building dimensions. The thickness of external brick walls are not less than 200 mm. Material properties and reinforced Concrete Member Sizes and Reinforcement for the building are illustrated in Table I and Fig. 5 respectively.

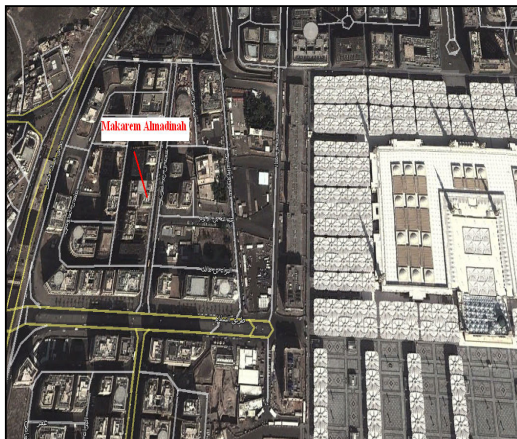

Fig. 1 Position of building in Madinah city from google



Fig. 2 Elevation of the case study building in Madinah



Fig. 3 Front view of the case study building in Madinah

TABLE I
MATERIAL PROPERTIES FOR BUILDING

concrete strength*	35000kN/m ²	F ['] c
rebar yield strength	415000 kN/m ²	F _y
modulus of elasticity of concrete	2.4E+7kN/m ²	E _c
modulus of elasticity of rebar	2.0E+8 kN/m ²	E _s
Shear modulus	8352348kN/m ²	G
Poisson's ratio	0.2	Y

*There properties were obtained from the original drawings

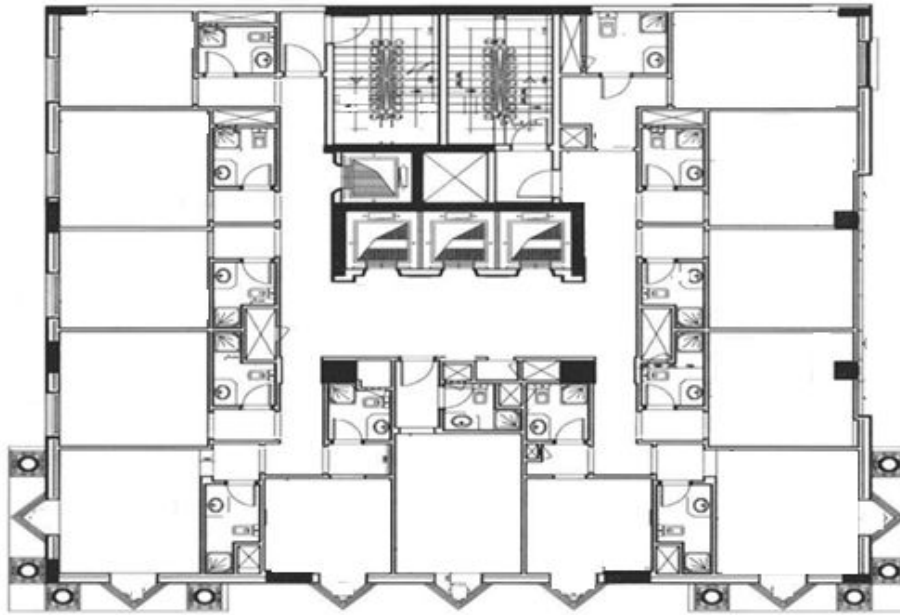

Fig. 4 Typical floor plan of the case study building in Madinah

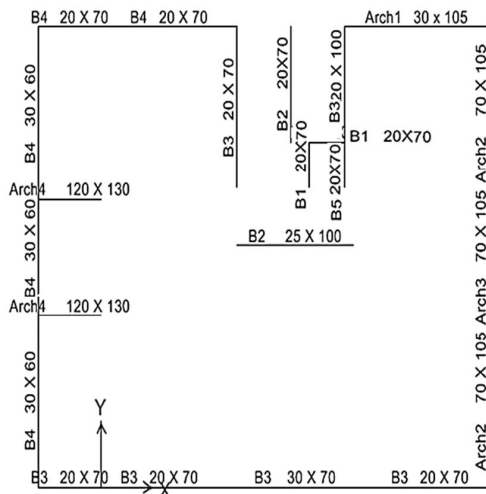

Fig. 5 Structural Plan

III. LOADING ASSUMPTIONS

- 1) Total Dead Load (D) is equal to $DL+SDL+CL$
- 2) Dead Load (DL) is equal to the self-weight of the members and slabs.
- 3) Super-imposed Dead Load (SDL) is equal to 3.5kN/m^2 . SDL includes partitions, ceiling weight, and mechanical loads.
- 4) Cladding Load (CL) is equal to 1.1 kN/m and is applied only on the boarder of building.
- 5) Live Load (L) is equal to 2.0 kN/m^2 .

Table II shows the total static loads for RC building due to EQ and Wind load cases according to Saudi Code for Loads and Forces - (SBC 301) (2008) [21]. The results in this table show that the EQ loads are the dominant in design.

TABLE II
TOTAL STATIC LOADS FOR RC BUILDING DUE TO EQ AND WIND LOAD CASES

Case	load (kN)	factored load (kN)
EQX	1716	1716
EQY	1716	1716
Wind x	1080	1728
Wind y	1182	1891

Factor loads for EQ=1.0 and for W=1.6 according to Saudi code (SBC301-2008).

IV. NONLINEAR MODELING OF BUILDING ELEMENTS

A. Nonlinear Modeling of RC Beam-Column Frame

The analytical model for a beam-column moment frame should represent strength, stiffness and deformation capacity of the beam-column joints along with potential failures due to flexure, shear and bond development. For nonlinear procedures, beams and columns are recommended to be modeled using concentrated plastic hinge models or distributed plastic hinge models so that they are capable of representing inelastic response. A representation of the monotonic load-deformation relationships are given in Fig. 6. The values of the deformations (or rotations) at the points B, C and D should be derived from experiments or rational analysis. The recommended plastic rotation capacities are given in FEMA 356. Alternative approaches to the calculation of rotation capacities are permitted with justified experiments and analysis. Fig. 6 illustrates how inelastic component strength and stiffness properties are used to create idealized force-deformation relationships.

B. Nonlinear Modeling of Shear Wall

Precise modeling for the nonlinear behavior of reinforced concrete (RC) shear walls, which are the major lateral-force-resistant structural member in high-rise buildings, is an

important task. As the cross section of the shear wall member is much bigger than that of the beam and column members, its deformation behavior under the lateral load is more complicated. Based on the principles of composite material mechanics, a multi-layer shell element model is proposed [22] to simulate the coupled in-plane/out-plane bending or the coupled in-plane bending-shear nonlinear behaviors of RC shear wall. The multi-layer shell element is based on the principles of composite material mechanics and it can simulate the coupled in-plane/out-plane bending and the coupled in-plane bending-shear nonlinear behaviors of RC shear wall. Basic principles of multi-layer shell element are illustrated by Fig. 7. The shell element is made up of many layers with different thickness. The rebar layer set as orthotropic with two principal axes as shown in Fig. 8.

C. Modelling Infill Walls as Struts for In-fill RC Frames

Masonry infill can be modeled as compression strut as recommended by ASCE/SEI 41 [23] and NBCC (2005) [24] for the calculations of strengths and effective stiffness of the infill panels. The equivalent strut shall have the same thickness and modulus of elasticity as the infill panel it represents, Fig. 8. The tensile strength of masonry is negligible and only compression diagonal strut is liable to resist the lateral load properties of brick masonry infill. The Strut is provided with hinges at ends to so that the strut doesn't carry any moment.

The axial stiffness coefficient $E_{strut} A_{strut}$ in the cross diagonal struts can be expressed in terms of the shear stiffness $G_w A_w$ of the infill panel and the inclination (θ) of the strut from, [25]:

$$2 (E_{strut} \cdot A_{strut}) = G_w \cdot A_w / (\cos 2\theta \cdot \sin \theta) \quad (1)$$

Using the relation between the axial stiffness of the strut and the shear stiffness of the panel, the axial stiffness coefficient $E_{strut} A_{strut}$ can be determined. The above equation can be approximately satisfied by two assumptions:

- The width of the struts calculated according to the limitation of Canadian code NBCC (2005) [24].
- The modulus of elasticity of the masonry wall, E_m and the shear modulus, G_w are calculated such as $E_m = 550f_m$ and the shear modulus, $G_w = 0.40E_m$ where, f_m is the compressive strength of the masonry wall material, ASCE-41.

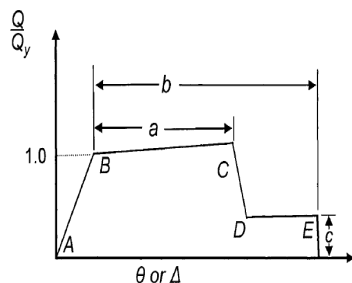
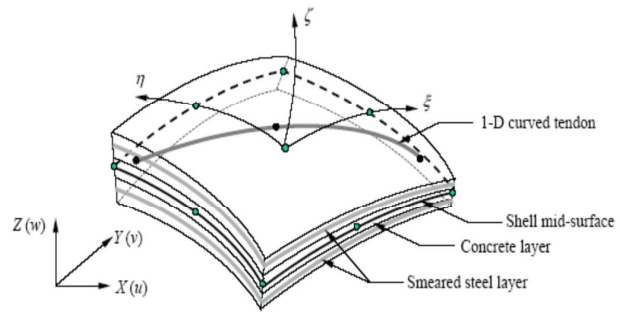
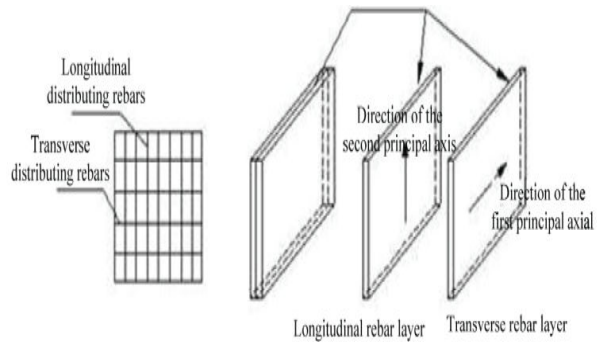

Fig. 6 Generalized force-deformation relation for concrete elements or components



(a) Multi-layer shell element



(b) Settings of the rebar layers

Fig. 7 Nonlinear modeling of shear wall

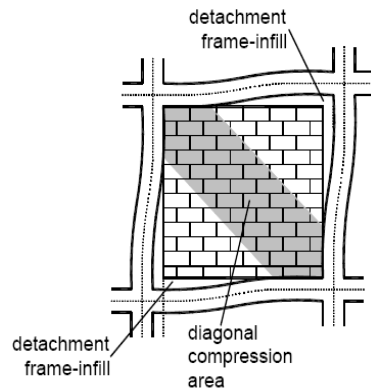
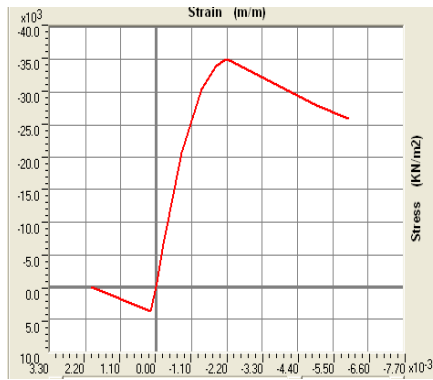

Fig. 8 Strut model analogy of in-filled frames

V. MATHEMATICAL MODELS

For the 15-story building, two mathematical models, Model I and Model II, were created using SAP2000 [26] program, Fig. 10. Model I (frame elements without infill wall). Model II (strut infill-update model from Field test) This model is developed from Model I by add modeling of infill walls as strut model according to suggested limitation from field test, [25], [24]. Stress-strain curves for concrete, steel bares and brick wall are illustrated in Fig. 9.



(a) Stress-strain curve for concrete

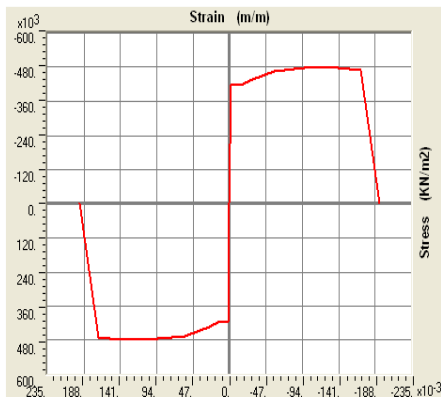

(b) Stress-strain curve for steel bare

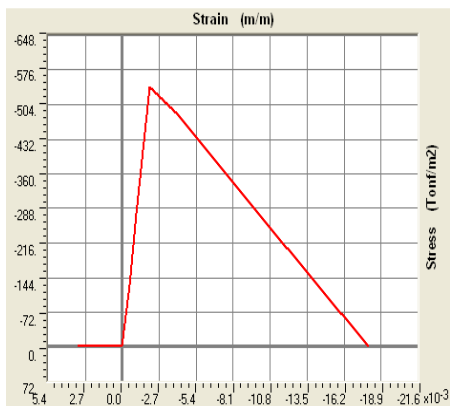

(c) Stress-strain curve for clad brick

Fig. 9 Stress-strain curves introduced in SAP2000 [26]

TABLE III
MEASURED MODES FOR THE BUILDING

Mode	Modal parameters MDOF	
	Type	T (sec.)
1	Translation X	0.703
2	Translation Y	0.58
3	Coupled	0.23

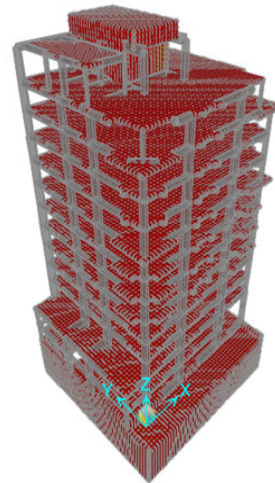

(a) Model I for the building (frame element + slab)

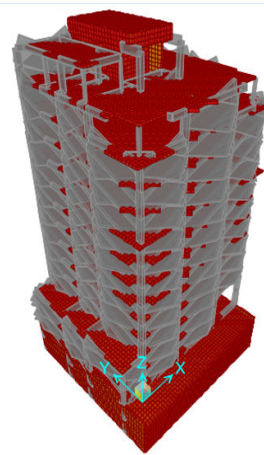

(b) Model II for the building (frame element + slab + strut clad)

Fig. 10 Mathematical models

VI. RESULTS AND DISCUSSIONS

A. Experimental and Theoretical Frequencies as well as Mode Shapes

A validation of the proposed structural numerical models for this 15-storey RC building can be achieved by comparing the experimentally measured and the analytically estimated natural frequencies.

Experimentally, eight server-type accelerometers with relevant signal conditioners were used for ambient response measurement. The measurements were performed at the four corners of plan on the top floor of the building and sufficient response signal were obtained. From the measured signal records and their normalized power spectra, the fundamental frequencies and the corresponding mode shapes in transverse, longitudinal and tensional directions were determined according to ambient vibration measurements procedure explained by [25].

Theoretically, a study has been conducted to assess

fundamental transverse, longitudinal, and torsional periods of the 15-storey RC building and to determine the effect of considering non-structural elements (infill walls) in structural model. Modal analysis has been carried out for three different models of the building using SAP2000 program. These models are: Model I (frame elements without infill wall) and Model II (frame elements with infill walls as strut elements).

Table III summarizes the first three natural periods measured for the building i.e. 0.703 sec, 0.58 sec and 0.23sec. The corresponding transverse, longitudinal and torsional mode shapes are illustrated in Fig. 11. Figs. 12-14 show that the corresponding mode shapes in transverse, longitudinal and coupled directions are similar for Model II. The corresponding mode shapes for Model I are completely different. Table IV summarizes the first six natural periods calculated for the two models of the building.

TABLE IV
THEORETICAL MODES FOR THE BUILDING

Mode number	Eigen values from modal analysis T (sec.)	
	Model I (frame elements without infill wall)	Model II (frame elements with infill wall as strut element)
1	1.529	0.715
	Not Pure Coupled	First Translation X
2	1.273	0.581
	Not Pure coupled	First Translation Y
3	0.906	0.326
	First Translation Y	First Coupled
4	0.440	0.235
	Second Coupled	Trans X+ Coupled
5	0.334	0.213
	Second Coupled	Trans Y+ Coupled
6	0.225	0.208

Fig. 12 shows that the first period is 1.529 sec and 0.715 sec for Model I and Model II respectively. Fig. 13 shows that the second period is 1.273 sec and 0.581 sec for Model I and Model II respectively. Similarly, Fig. 14 shows that the third period is 0.906 sec and 0.326 sec Model I and Model II respectively.

From the analysis investigations presented in Figs. 11-14, the following remarks can be seen:

- A good agreement was found between the experimentally measured periods and the numerically calculated periods with the infill wall Model II. The corresponding mode shapes in transverse, longitudinal and torsional directions are similar.
- Modeling the building without infill wall, Model I, gives different results for both period values and corresponding mode shapes. The first and second periods i.e. 1.529 sec and 1.273 sec are torsion modes while the third period i.e. 0.906 sec is transverse mode in Y direction.
- For modeling the building with infill wall, in Model II have been adjusted to give accurate results similar to the field. This show the importance of modeling infill walls as it significantly contributes in changing dynamic characteristic of the building.
- By considering the above facts, the main results of the

study is that the contribution of infill walls should be carefully judged by considering the importance of them in changing dynamic response and collapse status of existing RC structures.

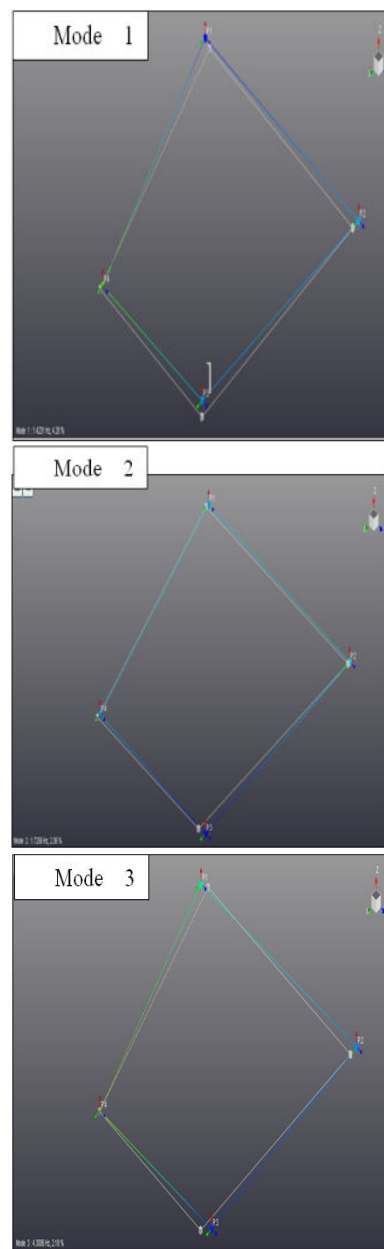

Fig. 11 Experimental mode shapes for the building

(a) $T_1=1.529$ sec (Model I) no infill wall(b) $T_1=0.715$ sec (Model II) infill wall strut element

Fig. 12 Theoretical mode shape (1) for different models for the building

(a) $T_2=1.273$ sec (Model I) no infill wall(b) $T_2=0.581$ sec (Model II) infill wall strut element

Fig. 13 Theoretical mode shape (2) for different models for the building

(a) $T_3=0.906$ sec (Model I) no infill wall(b) $T_3=0.326$ sec (Model II) infill wall strut element

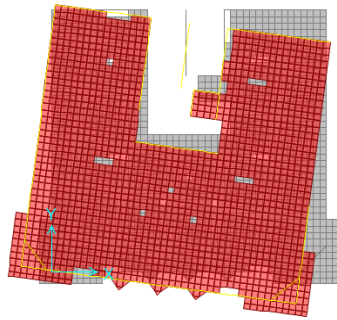
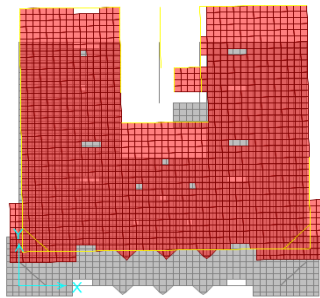
Fig. 14 Theoretical mode shape (3) for different models for the building

B. Hinge Status at Target Displacement for Pushover Analysis of RC Building

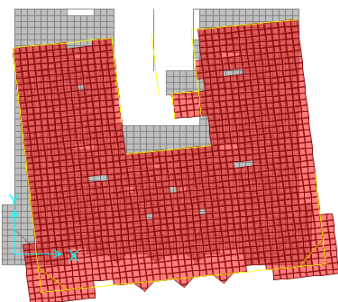
The lateral load pattern in Madinah City corresponding to the Saudi Building Code - Structural requirements for Loads and Forces - (SBC 301-2008 [23]) is adopted and applied as auto lateral load pattern in SAP 2000. The load pattern is calculated using $DL+SDL+0.25LL$ for the EQ load case. The direction of monitoring the behavior of the building is same as the push direction. In case of columns, program defined auto PM2M3 interacting hinges are provided at both the ends according to FEMA 356, while in case of beams, M3 auto hinges are provided.

In this study, displacement-controlled pushover analyses were performed on the two models for 15storey RC building using SAP2000 program in order to determine the performance level and deformation capacity (capacity curve).

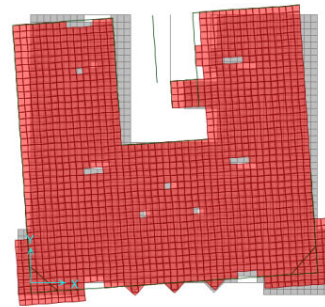
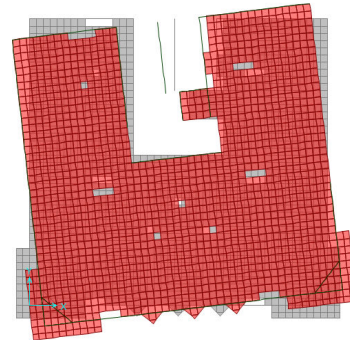
Columns isometric shapes for hinge status at target displacement for the two studied models are illustrated in Figs. 15 and 16 for XX and YY directions respectively. From these figures, it is observed that:

- In case bare frame Model I, Figs. 15 (a) and 16 (a), all columns are in B-LS range (i.e. operational range to collapse prevention range) and plastic hinges are distributed along many stories.
- In case of considering masonry wall, Model II, Figs. 15 (b) and 16 (b), most plastic hinges for columns are concentrated at lower stories and in B range (i.e. operational range) which is acceptable criteria for hinges.

The following comments for the above results can be deduced:-

- 1- The participation of RC shear walls in the lateral load resisting mechanism for the studied Models is considerable and therefore, decreases the formation of plastic hinges and improves their performance range along this building.
- 2- The above results show that modeling building with infill walls has greater strength as compared to building without infill walls. The presence of the infill walls increases the lateral stiffness considerably. Due to the change in stiffness and mass of the structural system, the dynamic characteristics change as well. The total storey shear force increases considerably as the stiffness of the building increases in the presence of masonry infill. This is useful to understand the contribution of infill walls in formation of plastic hinges in beams and columns in multistory frame.

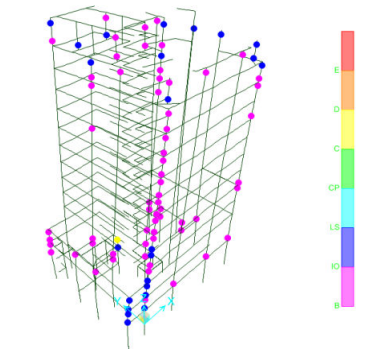

(a) Model I (frame element +slab)

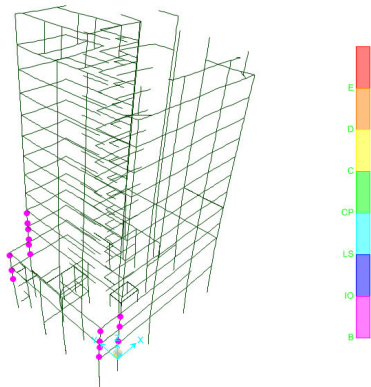

(b) Model II (frame element +slab+ infill walls strut element)

Fig. 15 Columns isometric shape for hinge status at target displacement, static nonlinear analysis XX

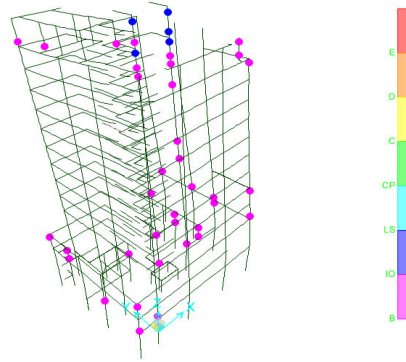

(a) Model I (frame element +slab)

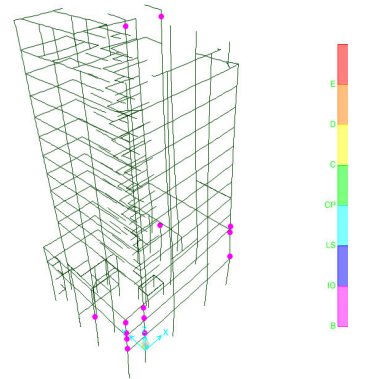

(b) Model II (frame element +slab+ infill walls strut element)

Fig. 16 Columns isometric shape for hinge status at target displacement, static nonlinear analysis YY

TABLE V
BASE SHEAR AND TARGET DISPLACEMENT VALUES FOR THE TWO MODEL

Case	Target Value	Model I (No clad)	Model II (infill walls) strut element
Case x-x	V_B (kN)	18800	20400
	δ (m)	0.367	0.061
Case y-y	V_B (kN)	15100	18300
	δ (m)	0.289	0.086

Figs. 17 and 18 show the building capacity response up to failure for the two studied models in X direction and in Y direction respectively. The strength and stiffness of the infilled frame is significantly increased due to the presence of infill, but the displacement capacity decreases, which is evident from the displacement profiles in these figures.

The maximum base shear (V_B) and target displacement (δ) values for the three different models are summarized in Table IV. Table VI shows that the ratio of base shear of Model II (with infill walls strut element) to the corresponding value of base shear for Model I (without infill) are 1.085 and 1.21 in X and Y directions respectively.

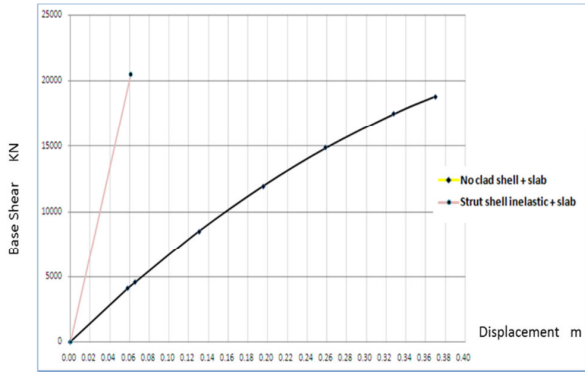

Fig. 17 Comparison of pushover curves for the two models, static nonlinear analysis X-X

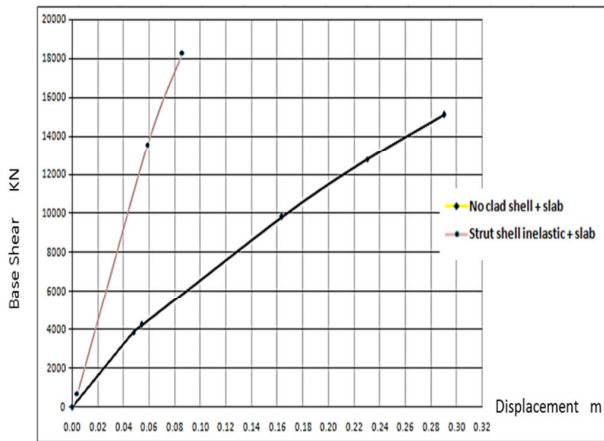

Fig. 18 Comparison of pushover curves for the two models, static nonlinear analysis Y-Y

C. Yield Point from the Pushover Curve

The 15-story RC building (Duel system with moment frame) is stiff enough due to the presence of RC shear walls and the contribution of infill walls has not greater strength. Figs. 19-21 show the hinge formulations and stress distribution in RC shear walls for Model I at first yield point (D_y, V_y) and ultimate point ($V_{ultimate}, D_{ultimate}$) of the pushover curve. The ratios of V_y (equal $0.6 V_{ultimate}$) to V at first yield for Model I and Model II are summarized in Table VIII. It is observed from these tables and figures that:

- 1- For Model I (frame elements without infill wall):
 - The yield force (V_y) obtained from 0.6 ultimate target value of pushover curve is different from those obtained from the rule V (first yield) in columns. The ratio factor is 1.45 and 1.15 in X and Y direction respectively.
 - There is a lot of plastic hinge formulations at yield force (V_y) obtained from the rule of 0.6 ultimate target value.
- 3- For Model II (frame elements with infill wall as strut elements):
 - The yield force (V_y) obtained from 0.6 ultimate target value of pushover curve is different from those obtained from the rule V (first yield) in columns. The ratio factor is 1.14 and 1.32 in X and Y direction respectively.

- There is a limited number of plastic hinge formulations at yield force (V_y) obtained from at 0.6 ultimate target value.

From the above results and according to the distribution of plastic hinge formulations, it is recommended to calculate:

- For reinforced concrete building (Duel system with moment frame), which have completely different distribution of plastic hinge formulations, the yield force (V_y) from the rule V (first yield) in columns have to be used to get safe and reliable results for the over strength factor for the building.
- For braced frame resisted by a truss mechanism formed by the masonry infill panel, which have nearly similar distribution of plastic hinge formulations, the yield force (V_y) obtained from the rule of 0.6 ultimate target value or the rule V (first yield) in columns can be used.

TABLE VI
THE RATIO OF BASE SHEAR FOR MODEL WITH INFILL TO MODEL WITHOUT INFILL IN X OR Y DIRECTIONS

Case	Base shear for Model II Base shear for Model I
Case x-x	1.085
Case y-y	1.21

TABLE VII
V YIELD VALUES (kN)

Case	Target Value	Model I (No clad)	Model II (infill walls) strut element
Case x-x	V_y equal $0.6 V_{ultimate}$	11280	12300
	V at first yield	7800	10800
Case y-y	V_y equal $0.6 V_{ultimate}$	9060	12200
	V at first yield	7900	9200

TABLE VIII
RATIO OF V YIELD TO V AT FIRST YIELD

Case	Ratio	Model I (No clad)	Model II (infill walls) strut element
Case x-x	$0.6 V_{ultimate}$	1.45	1.14
Case y-y	V at first yield	1.15	1.32

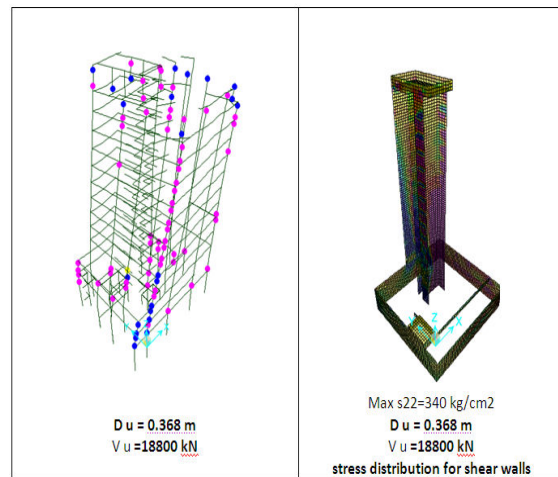

Fig. 19 V_u for Model I (frame element) XX

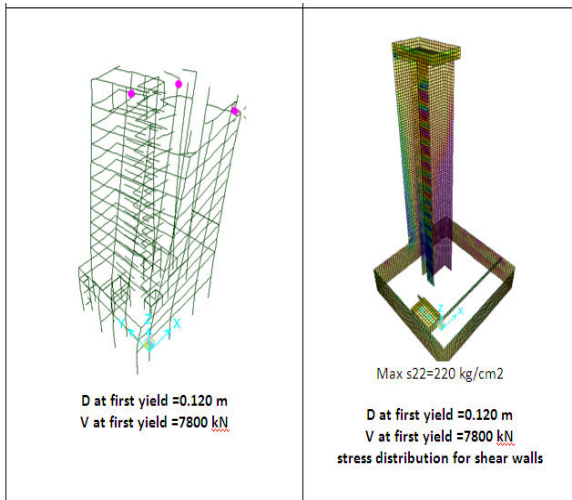

Fig. 20 Vyield for Model I (frame element) XX

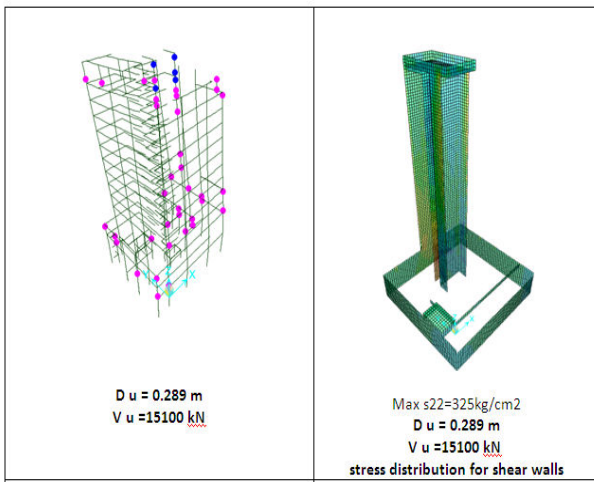

Fig. 21 Vu for Model I (frame element) YY

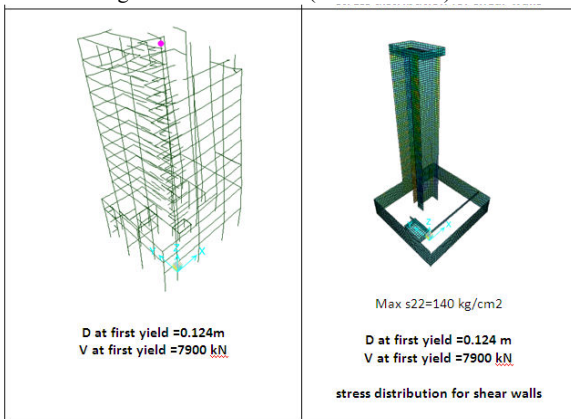

Fig. 22 V yield for Model I (frame element) YY

D. Response Reduction Factor R from Capacity and Demand Spectra

The capacity diagram and the demand diagram are shown in

Figs. 23 and 24 in X and Y directions for Model I and Model II respectively. The results indicate that:

For Model I: (frame elements without infill wall),

- The performance base shear V performance is 3134kN and 3212kN in X and Y directions respectively.
- The lowest resultant response reduction factor R equals 4.54.

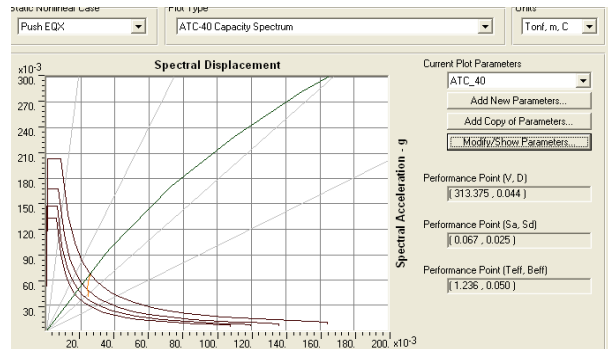

(a) Model I (frame element +slab)

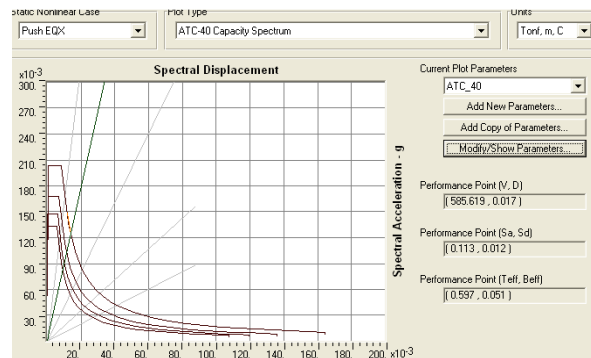

(b) Model II (frame element +slab+ strut element)

Fig. 23 ATC40 Capacity spectrum, EQX, design spectrum function in Madinah

For Model II: (frame elements with infill wall strut element),

- The performance base shear V performance is 5856kN and 4928kN in X and Y directions respectively.
- The lowest resultant response reduction factor R equals 4.84.

The following comments for the above results can be deduced:-

- 1- The total shear force increases considerably as the stiffness of the building increases in the presence of masonry infill. The lateral load resisting mechanism of the masonry infill frame is essentially different from the bare frame. The bare frame acts primarily as a dual system with moment frame. In contrast, the infill frame behaves like a braced frame resisted by a truss mechanism formed by the compression in the masonry infill panel and tension in the column.
- 2- The values of response modification factor R as per international standards (Saudi Building Code SBC 301

and ASCE-7 [27]) for Duel system with moment frame is 4.5. This means that:

- Model I (frame elements without infill wall) satisfy the code requirements for response modification factor R.
- Including infill wall in the analysis, Model II (frame elements with infill wall strut element), increase the stiffness of the building and give higher value of R satisfying the code requirements.

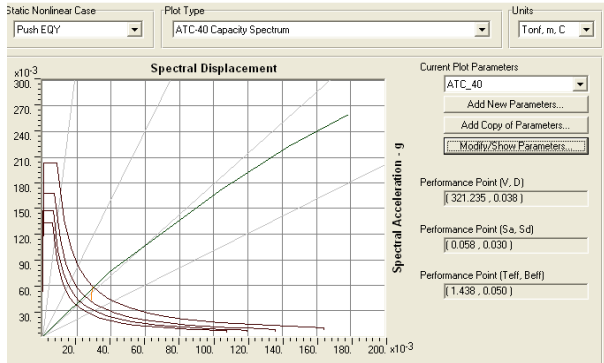

(a) Model I (frame element +slab)

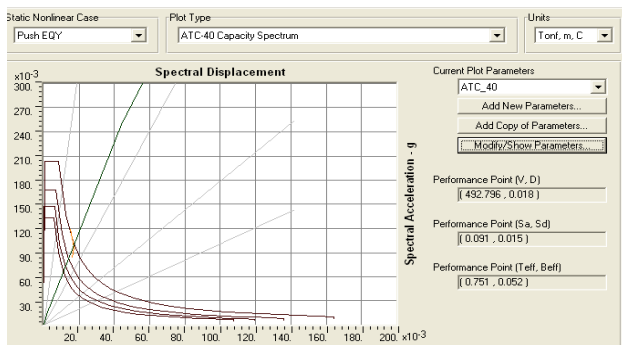

(b) Model II (frame element +slab+ strut element)

Fig. 24 ATC40 Capacity spectrum, EQY, design spectrum function in Madinah

TABLE IX
RESULTS OF PUSHOVER ANALYSIS ACCORDING TO ATC-40, Y-AXIS DIRECTION

item	Model I (no-infill)	Model II (with infill)
S_a	0.058	0.091
S_d	0.030	0.015
W (kN)	81140	81140
V_p (kN)	3210	4928
Dp (m)	0.038	0.018
Du(m)	0.289	0.10
B_{eff}	0.050	0.0520
T_{eff} (s)	1.438	0.7500
V_y (kN)	7900	12200
V_d (kN)	1716	2160
D_y	0.124	0.066
μ	1.00	1.00
Ω	4.60	5.64
R_u	1.00	1.00
R	4.60	5.64

TABLE X
RESULTS OF PUSHOVER ANALYSIS ACCORDING TO ATC-40, X-AXIS DIRECTION

item	Model I (no-infill)	Model II (with infill)
S_a	0.067	0.113
S_d	0.025	0.012
W (kN)	81140	81140
V_p (kN)	3133	5856
Dp (m)	0.044	0.017
Du(m)	0.368	0.06
B_{eff}	0.050	0.051
T_{eff} (s)	1.236	0.597
V_y (kN)	7800	12300
V_d (kN)	1716	2540
D_y	0.012	0.037
μ	1.00	1.00
Ω	4.54	4.84
R_u	1.00	1.00
R	4.54	4.84

VII. SUMMARY AND CONCLUSION

The ambient vibration measurements (AVM) on buildings have provided valuable data for the validation and updating of the detailed finite element models. Experimentally, eight server-type accelerometers with relevant signal conditioners were used for ambient response measurement of an existing 15 storey RC building in Madinah City in Saudi Arabia. From the measured signal records and their normalized power spectra, the fundamental frequencies and the corresponding mode shapes in transverse, longitudinal and torsion directions were determined. Further, a theoretical study has been conducted to assess fundamental transverse, longitudinal and torsion periods of the 15 storey RC building and to determine the effect of considering non-structural elements (infill walls) in structural model. Modal analysis has been carried out for two different models of the building using SAP2000 program. These models are: Model I (frame elements without infill wall) and Model II (frame elements with infill walls as strut elements). After, updated the mathematical models for this building with the experimental results, 3D pushover analysis (Nonlinear static analysis) has been carried out incorporating inelastic material behavior for concrete, infill and steel.

The results for the studied building show that:

- A good agreement was found between the experimentally measured periods and the numerically calculated periods with the infill wall. The corresponding mode shapes in transverse, longitudinal and torsion directions are similar. On contrast, modeling the building without infill wall give different results for both period values and corresponding mode shapes. This shows the importance of contribution of infill walls in changing dynamic characteristic of the building and giving accurate results similar to the field
- Seismic evaluation of the studied 15-storey RC building (Duel system with moment frame) indicates that this building satisfy the code requirements for response modification factor (4.5 according to Saudi Building Code SBC 301).

- Performing pushover analysis of RC buildings required checking the distribution of plastic hinge formulations at the chosen yield force level (V_y) as it is the main factor for calculation the over strength factor for the building.
- Including infill wall in the analysis, according to updated model from field measurements give increase the stiffness of the building and give higher value of response modification factor R . The structural performance level and hinge status at target displacement are improved after accounting for masonry infill walls modeling. However, the studied 15-storey RC building (Duel system with moment frame) is stiff enough due to the presence of RC shear walls and the contribution of infill walls has not great strength especially in x-axis direction.

REFERENCES

- [1] Roobol, J. (2007) "Cenozoic faults in Western Saudi Arabia" In: 7th meeting of the Saudi society for geosciences, King Saudi University, Riyadh, Saudi Arabia.
- [2] Al-Saud, M. (2008) "Seismic characteristics and kinematic models of Makkah and central Red Sea regions" Arab J Geosci 1:49–61.
- [3] Aldamegh, S., Moussa, H. Al-Arifi, S. and Moustafa, M. (2012) "Focal mechanism of Badr earthquake, Saudi Arabia of August 27, 2009" Arab J Geosci (2012) 5:599–606.
- [4] Midorikawa, S.,(1990) "Ambient vibration test of buildings in Santiago and Viña del Mar", A report on the Chile-Japan joint study project on seismic design of structures, The Japan international cooperation agency.
- [5] Negulescu C., Radoi, R. and Aldea, A. (2004) "Microtremor measurement for evaluation of building vibration characteristics", Report, National Center for Seismic Risk Reduction, Bucharest, Part 1 - 23p. and Part 2, - 20p.
- [6] Michel C., Guéguen P. and Bard P.Y.(2008)"Dynamic parameters of structures extracted from ambient vibration measurements", an aid for the seismic vulnerability assessment of existing buildings in moderate seismic hazard regions, Soil Dynamics and Earthquake Engineering; 28 (8), 593-604.
- [7] Demetriu, S. and Aldea, A.(2012)"Modal parameters of RC frame structure identified from ambient vibration measurements" 15 WCEE, Lisbona.
- [8] Crawford, R., and Ward, H. S., (1964) "Determination of the Natural Period of Buildings," Bulletin of the Seismological Society of America, Vol. 54, No. 6, pp. 1743-1756.
- [9] Trifunac, M. D., (1972) "Comparison between Ambient and Forced Vibration Experiments," Earthquake Engineering and Structural Dynamics, Vol. 1, pp. 133-150.
- [10] ATC-40 (1996) "Seismic Evaluation and Retrofit of Concrete Building" Report, Applied Technology Council. Redwood City, California.
- [11] Federal Emergency Federal Agency, FEMA-356. Pre-standard and Commentary for Seismic Rehabilitation of Buildings. Washington DC, 2000.
- [12] Chopra, A.K. and Chintanapakdee C.(2003) "Evaluation of modal pushover analysis using generic frames" Earthquake Engineering and Structural Dynamics;32(3): 417-42.
- [13] Chopra, A.K. and Chintanapakdee C.(2004) "Evaluation of modal and FEMA pushover analyses: vertically regular and irregular generic frames" Earthquake Spectra; 20(1):255-71.
- [14] Chopra AK, Goel R.K. and Chintanapakdee C.(2004) "Evaluation of a modified MPA procedure assuming higher modes as elastic to estimate seismic demands" Earthquake Spectra; 20(3):757-78.
- [15] Chopra, A.K. and Goel, R.K. (2002) "A modal pushover analysis procedure for estimating seismic demands for buildings" Earthquake Engineering and Structural Dynamics 31(3):561-82.
- [16] Kunnath S.K. and Kalkan E. (2004) "Evaluation of seismic deformation demands using nonlinear procedures in multistory steel and concrete moment frames" ISET Journal of Earthquake Technology 41(1):159_ 82.
- [17] Federal Emergency Federal Agency, FEMA-440, "Improvement of nonlinear static seismic analysis procedures" Federal Emergency Management Agency, Washington, D.C., 2005.
- [18] Akkar, S. and Metin, A. (2007) "Assessment of improved nonlinear static procedures in FEMA-440" Journal of Structural Engineering, ASCE; 133(9):1237_46.
- [19] Kalkan E, and Kunnath, S.K.(2007) "Assessment of current nonlinear static procedures for seismic evaluation of buildings". Engineering Structures; 29(3): 305-16.
- [20] Irtem E, and Hasgul U.(2009) "Investigation of effects of nonlinear static analysis procedures to performance evaluation on low-rise RC buildings" Journal of Performance for Constructed Facilities, ASCE; 23(6):456_66.
- [21] Saudi Building Code - Structural requirements for Loads and Forces - SBC 301 (2007).
- [22] Miao, Z. W. Lu1, X. Z. Jiang1, J. J. and Ye, L. P. (2006) "Nonlinear FE Model for RC Shear Walls Based on Multi-layer Shell Element and Microplane Constitutive Model Computational Methods in Engineering and Science EPMESC, Sanya, Hainan ,China by the American Society of Civil Engineers, ASCE/SEI 7-10..
- [23] ASCE/SEI 41,(2006) "Seismic Rehabilitation of Existing Buildings, American Society of Civil Engineers, Reston, Virginia
- [24] NBCC (2005). National Building Code of Canada 2005, National Research Council, Ottawa.
- [25] Tarek, M. Alguhane (2014) "Monitoring of Buildings Structures in Madinah", Ph.D, Ain Shams University Faculty of Engineering 2014.
- [26] SAP2000 (2011) Integrated Software for Structural Analysis & Design. Computers & Structures, Inc., Berkeley, California, USA.
- [27] ASCE 7-10 (2010) "Minimum Design Loads for Buildings and Other Structures", Published.