

DC-to-DC Converters for Low-Voltage High-Power Renewable Energy Systems

Abdar Ali, Rizwan Ullah, Zahid Ullah

Abstract—This paper focuses on the study of DC-to-DC converters, which are suitable for low-voltage high-power applications. The output voltages generated by renewable energy sources such as photovoltaic arrays and fuel cell stacks are generally low and required to be increased to high voltage levels. Development of DC-to-DC converters, which provide high step-up voltage conversion ratios with high efficiencies and low voltage stresses, is one of the main issues in the development of renewable energy systems. A procedure for three converters—conventional DC-to-DC converter, interleaved boost converter, and isolated flyback based converter, is illustrated for a given set of specifications. The selection among the converters for the given application is based on the voltage conversion ratio, efficiency, and voltage stresses.

Keywords—Flyback converter, interleaved boost, photovoltaic array, fuel cell, switch stress, voltage conversion ratio, renewable energy.

I. INTRODUCTION

THE increase in usage of fossil fuels, oil, and gas over the last few decades has created threat of depletion of these fuels. The environmental concerns such as green house effect, atmospheric pollution, ozone layer depletion, and high temperatures also limit the exploration of nonrenewable sources, which has resulted in high energy prices in the international market and has adversely affected the economies of countries particularly those of developing countries. As a result of worsening energy crises and aggravated environmental pollution, renewable energy sources have received worldwide attention.

The primary focus of research on energy is on the generation of electric power from renewable energy sources, which are truly emission-free and inexpensive, and can provide power with high reliability. Nowadays, about 14×10^{12} W, which represents only 0.5% of the world's power consumption, comes from renewable sources per annum. It is expected that by the year 2050, about 40×10^{12} W will be produced from renewable energy sources annually [1].

Many applications need efficient and high step-up DC-to-DC converters. For instance, in a high intensity discharge (HID) lamp ballast, which is used in headlamps of automobiles in which the starting voltage is up to 400 V [2], the DC-to-DC converter needs to step-up the 12 V of the battery voltage up to 100 V. In computer and telecommunication industries, which use 48 V battery back-up plant, a good choice for offering hours of reserve time during outages of AC mains [3], [4], the DC input converter must

boost the 48 V of DC bus voltage to about 380 – 400 V. The DC input converter in this case is more efficient and less complex than uninterruptible power supply (UPS) [3]–[5].

The voltages generated by renewable energy sources such as photovoltaic (PV) arrays and fuel cell stacks are generally low. These voltages need to be increased to high voltages for certain applications such as 380 V for full-bridge inverter and 760 V for half-bridge inverter of a 220 V AC grid-connected system. One of the challenges in the development of renewable energy systems, which are based on photovoltaic modules and fuel cell stacks, is the conversion of relatively low DC voltage to high DC voltage. DC-to-DC converters with high step-up ratios are required for this purpose. Various DC-to-DC converters exist that are more appropriate for stepping-up low voltages of PV arrays and fuel cell stacks to required high voltages for inverters.

In this paper, three DC-to-DC converters—interleaved boost converter, flyback based converter, and conventional boost converter have been selected and designed for photovoltaic- and fuel cell-based renewable energy systems. The characteristics of these DC-to-DC converters are studied with the objective to determine the most appropriate converter for the photovoltaic- or fuel cell-based renewable power generation system. OrCAD PSpice simulation of the converters has been done to verify the designs. Special emphasis is on efficiency, switch stresses, and voltage conversion ratio, which are the key requirements of renewable energy systems. Flyback based converter has been recommended for low-voltage high-power applications on the basis of comparative analysis.

The rest of the paper is organized as follows: Section II presents literature review of various DC-to-DC converters with reference to their characteristics and advantages for renewable energy sources. Section III discusses the selected converters—flyback based and interleaved boost converters. Sections IV and V discuss parameters of the flyback based and interleaved boost converters. Section VI discusses design specifications and parameters. Section VII provides the simulation results and discussions on simulated waveforms. Section VIII concludes the paper along with future work.

II. LITERATURE REVIEW

Several types of DC-to-DC boost converters are available. However, not all of these converters are suitable for low-voltage high-power renewable energy systems. A novel interleaved boost converter with voltage conversion ratio, three times higher than that of conventional arrangement and reduced voltage switch stresses has been achieved in

Abdar Ali, Rizwan Ullah, and Zahid Ullah are with the Department of Electrical Engineering, CECOS University of Information Technology and Emerging Sciences, F-5, Phase-VI, Hayatabad, Peshawar, Pakistan (e-mail: abdar@cecos.edu.pk, rizwan@cecos.edu.pk, zahidullah@cecos.edu.pk).

[6] for UPS applications but at the expense of additional components—two extra diodes, two extra inductors, and two extra capacitors. A high-power multi-leg interleaved boost converter with digital signal processor based controller has been designed in [7], considering factors like DCM operating range, inductor size and weight, device ratings, and converter efficiency; however, this converter has disadvantages of high parts count, high cost, large size, low efficiency, and low reliability.

A single-stage converter for grid-connected photovoltaic power generation system has been proposed in [8] to address the drawbacks of [7]. The single stage converter has desirable characteristics of high efficiency, better utilization of PV array, low cost, and compact size. In addition, the PV array appears as a floating source to the grid due to the converter that increases the overall safety of system and avoids the requirement of transformer for safety and grounding purposes. The grid-connected photovoltaic system has an edge over stand-alone photovoltaic system in terms of battery back-up. Two other converters, conventional H-bridge inverter followed by step-up transformer and PV array with sufficiently high voltage followed by H-bridge inverter [9]–[11], can also be used but have some problems. The use of transformer adds to the bulk and cost of system and also increases losses. A PV array with high DC voltage also has drawbacks of hot spots during partial shading of array, reduced safety, and increased leakage current through parasitic capacitance between the panel and system ground. In the case of single-stage converter between PV array and grid, advantages such as maximum power point tracking (MPPT), boosting, and inversion are available in one converter that leads to a compact system. Such a compact system is the modern day need to have highly integrated systems of high reliability, high performance, reduced weight, and low cost.

A three-phase transformer-isolated DC-to-DC converter using phase-shift modulation has been designed for low-voltage fuel cell applications [12]. The key features of this converter include reduced turns ratio of transformer while maintaining same output voltage, reduced size of passive components of output filter capacitor and input DC bus capacitor using three-phase interleaving, removal of inductor current ripple at phase shift angles above 120° , and zero-voltage zero-current (ZVZC) switching over a wide range of load without requirement of auxiliary circuit. The frequency of output voltage ripple of rectifier has been increased to six times the switching frequency, which reduces the size of output filter significantly. The converter has an efficiency of greater than 96%.

In [13], DC-to-DC converters with high voltage conversion ratios, high efficiencies and simple circuits are studied. To achieve these characteristics, DC-to-DC converters with only diodes and coupled inductors instead of active switches have been employed. For efficiency improvement, two cascaded boost converter cells have been used, which result in the circuit complexity owing to two sets of active switches, magnetic components, and controller requirement. Because of high output voltage and high output power, the output rectifier of second stage of boost converter has severe reverse recovery

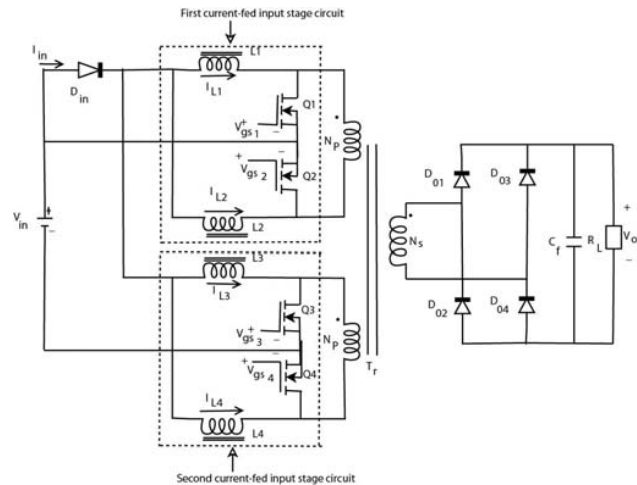

Fig. 1 Flyback based converter circuit. (I_{in} : input current, D_{in} : input diode, V_{in} : input voltage, L : coupled inductor, I_L : coupled inductor current, Q_1 , Q_2 , Q_3 , and Q_4 : active switches, V_{gs1} , V_{gs2} , V_{gs3} , and V_{gs4} : controlled signals for active switches, N_p : primary number of turns of transformer, N_s : secondary number of turns of transformer, T_r : transformer, D_{01} , D_{02} , D_{03} , and D_{04} : rectifier diodes, C_f : output filter capacitance, R_L : load resistance, and V_o : output voltage)

problems, which not only degrade efficiency but also lead to electromagnetic interference (EMI).

Instead of non-isolated converters or cascaded DC-to-DC converters, converters with coupled inductors like flyback and isolated single-ended primary-inductor converter (SEPIC) converters can be used. Although converters with coupled inductors such as flyback-based converters can easily achieve high voltage conversion ratios utilizing MOSFETs with low resistance at low power levels but leakage energy induces high voltage stresses, high switching losses, and severe EMI. A clamp mode coupled inductor converter, presented in [13], adds only one diode and a small capacitor and the converter operation is similar to that of its active clamp counterpart but with better performance. The whole arrangement of [13] increases the reliability of converter significantly owing to low cost and reduction in circuit complexity as compared to converters that employ active clamps.

An integrated boost-flyback converter (IBFC) has been used to achieve high efficiency with high voltage conversion ratio and low voltage switch stresses [14]. A drawback of the converter is that the efficiency is the highest for turn ratio of one and decreases when turns ratio deviates from this value. An optimum turn ratio is required to get the highest efficiency. The high step-up DCto-DC converters in [15]–[19] can be obtained but on the expense of extra devices such as diodes and output capacitors.

III. LOW-VOLTAGE HIGH-POWER CONVERTERS

Flyback based and interleaved boost converters have been selected for low-voltage high-power renewable energy systems. These converters can be used to produce high output voltage from low voltage sources such as photovoltaic arrays and fuel cells etc. and have advantages of high step-up conversion ratios, high efficiencies, and low switch

voltage stresses. Fig. 1 shows the circuit configuration of flyback based converter, which consists of two current fed input stage circuits, a coupled transformer, and a secondary bridge rectifier. Each input stage circuit is composed of two MOSFETs and two inductors. The duty ratios of the MOSFETs are greater than 0.5 to allow overlapping operation. Fig. 2a shows interleaved boost converter, which consists of two single-phase boost converter cells operating in parallel. The boost inductors are closely coupled with the same winding orientation. The equivalent circuit of the interleaved boost converter with three uncoupled inductors is shown in Fig. 2b. The uncoupled inductors in Fig. 2b are related to the coupled inductors in Fig. 2a by (1), (2), and (3).

$$L'_1 = L_1 - L_m \quad (1)$$

$$L'_2 = L_2 - L_m \quad (2)$$

$$L_m = k\sqrt{L_1 L_2} \quad (3)$$

IV. PARAMETERS OF FLYBACK BASED CONVERTER

The voltage conversion ratio of flyback based converter is derived by volt-second balance principle applied to the inductors and is expressed by (4).

$$M(D) = \frac{V_0}{V_{in}} = \frac{1}{n(1-D)} \quad (4)$$

where $M(D)$ is the voltage conversion ratio of the flyback based converter.

The voltage and current stresses of switches largely influence the cost of converter, which suggests evaluating the voltage and current stresses of the switches of converter. The voltage and current stresses of the switches in flyback based converter are given in (5) and (6). The switch stress is given by (7) and the total switch stress is defined in (8).

$$V_{stress} = nV_0 \quad (5)$$

$$I_{stress} = I_{L1} + I_{L2} + I_{L3} + I_{L4} = \frac{I_{in}}{2} \quad (6)$$

$$S = V_{stress} \times I_{stress} \quad (7)$$

$$S_T = \sum_{i=1}^k V_i I_i \quad (8)$$

In (8), k is the total number of switches, V_i is the voltage stress of switch i and I_i is the rms current (peak current is sometimes used instead of rms current) of switch i . The total switch stress of the flyback based converter is given by (9). The switch utilization is defined in (10). In a good converter design, switch utilization is kept high.

$$S = 4 \left(nV_0 \times \frac{I_{in}}{2} \right) \quad (9)$$

$$U = \frac{P_{load}}{S} \quad (10)$$

The inductance of inductors L_1 to L_4 is determined from the inductor current ripple by using (11).

$$L = \frac{DV_{in}}{\Delta i_L \times f_s} = \frac{4DV_{in}}{\Delta \times I_{in} \times f_s} \quad (11)$$

where $\Delta i_L = \Delta \times i_L$ and $i_L = I_{in}/4$, Δ is the percentage of inductor current. f_s is the switching frequency and Δi_L is the peak-to-peak ripple of inductor currents I_{L1} to I_{L4} .

Capacitance C_f is calculated from the required ripple Δv_o of output capacitor voltage as in (12).

$$C_f = \frac{I_0 \times (1-D)T_s}{\Delta v_o} = \frac{I_0 \times (1-D)T_s}{\Delta \times V_0} \quad (12)$$

where Δv_o is the peak-to-peak output voltage ripple and $\Delta v_o = \Delta \times V_o$

V. PARAMETERS OF INTERLEAVED BOOST CONVERTER

The voltage conversion ratio of the interleaved boost converter is determined from the steady state analysis given in (16).

$$A = [1 + 2(1-k)(0.5 + D)(1 - 2D - \delta D)] \quad (13)$$

$$B = 4(1-k)(1 - \delta D)L \quad (14)$$

$$C = \frac{4(1-k)L}{R_L T} \quad (15)$$

$$M(D) = \frac{V_0}{V_i} = \frac{A + \sqrt{A^2 - B[C + (1 - 2D - \delta D)]}}{2[C + (1 - 2D - \delta D)]} \quad (16)$$

$$R_L \geq \frac{B \times 4(1-k)L}{A^2 - 4(1-k)(1 - \delta D)(1 - 2D - \delta D)} \quad (17)$$

The voltage stress and current stress of switches in interleaved boost converter are given by (18) and (19), respectively.

$$V_{stress} = V_o \quad (18)$$

$$I_{stress} = I_{in,max}. \quad (19)$$

The inductance of the interleaved boost converter is determined from the inductor current ripple given in (20) where D is the duty ratio and D_{11} is the time interval during which interleaving between the boost converter cells occur.

$$L = \frac{V_i(1-D)T_s}{\Delta i_L} \quad (20)$$

The capacitance of interleaved boost converter is determined from the output voltage ripple and is given by (21).

$$C_f = \frac{V_0(D_1 - D_{11})T_s}{\Delta v \times R_L} \quad (21)$$

VI. DESIGN OF CONVERTERS

A. Design Specifications

The design specifications for the converters are:

- Input source: 1 kW PV array
- Input power, $P = 1$ kW
- Input voltage, $V_{in} = 48$ V
- Output voltage, $V_{out} = 380$ V
- Switching frequency, $f_s = 100$ kHz
- Time period, $T_s = 10$ μ s
- Input current, $I_{in} = 20.83$ A
- Output current, $I_{out} = 2.63$ A
- Load resistance, $R = 144.48$ Ω

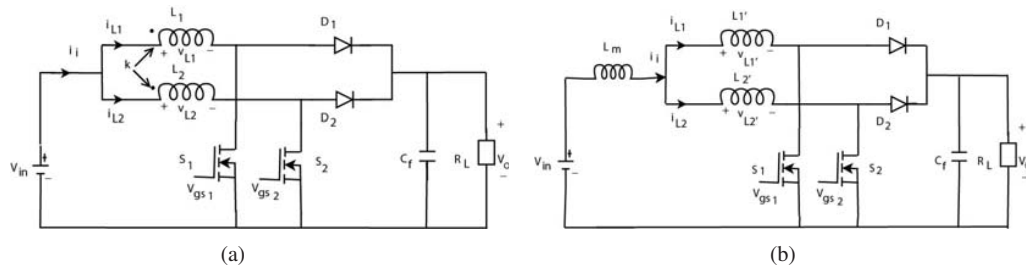

Fig. 2 (a) Interleaved boost converter (b) Equivalent circuit of the interleaved boost converter. (i_i : input current, L : coupled inductor, L' : uncoupled inductor, i_L : inductor current, L_m : mutual inductor, V_L : inductor voltage, D : diode, V_{in} : input voltage, S_1 and S_2 : active switches, V_{gs1} and V_{gs2} : controlled signals for active switches, C_f : output filter capacitance, R_L : load resistance, and V_o : output voltage)

TABLE I
DESIGNED PARAMETERS OF FLYBACK BASED, INTERLEAVED BOOST, AND BOOST CONVERTERS

| Parameters | Flyback based converter | Interleaved boost converter | Simple boost converter |
|------------------|-------------------------|-----------------------------|------------------------|
| V_{Stress} (V) | 152 | 380 | 380 |
| I_{Stress} (A) | 10.41 | 20.83 | 20.83 |
| S | 1583 | 7915 | 7915 |
| S_T | 6332 | 15831 | 7915 |
| U | 0.157 | 0.063 | 0.126 |
| L (μ H) | 210.22 | 103.15 | 67.13 |
| C_0 (μ F) | 21.85 | 30.23 | 60.48 |
| No. of MOSFETs | 04 | 02 | 01 |
| No. of Diodes | 04 | 02 | 01 |

The peak-to-peak ripple is chosen to be 30% of inductor current. The capacitor voltage ripple is chosen to be 0.1% of the output voltage. In most of the designs, the input and output voltages and load currents are all dictated by the design requirements and the inductance and ripple current are parameters free to be chosen by the designer. The inductance value is inversely proportional to the ripple magnitude but the inductor cost is directly proportional to the inductance value. To get a good compromise between the inductor and inductor cost, the inductor ripple is chosen to be 30% of the inductor current. The output voltage ripple is kept as low as possible, to get a pure dc voltage.

Since there are two unknowns in the flyback based converter output equation i.e. n and D ; therefore, to find the value of one, suitable value of the other unknown has to be chosen. Selecting $D = 0.68$ to allow overlapping between the switches gives rise to $n = 0.4$.

B. Designed Parameters

Using the design specifications given in Section VI-A, required parameters for the candidate converters are given in Table I.

VII. SIMULATION RESULTS AND DISCUSSION

A. Simulation Results

PSpice models of the flyback based converter, interleaved boost converter, and conventional boost converter have been

developed and designed using the given specifications. After successful simulation of converter circuits in OrCAD PSpice, the output voltages and powers waveforms, and switch currents and voltages waveforms of the three converters have been generated and are shown from Figs. 3-11. The purpose is to show which converter is better in terms of its voltage conversion ratio, efficiency, and switch stresses than the other converters for low-voltage high-power applications. Summary of the simulated converters is given in Table II.

B. Discussion

From Table II, it is clear that the output voltage produced by simulated flyback based converter is 371.58 V, which is more than that of 362.39 V of boost and 362.89 V of interleaved boost converters. Table II shows that the voltage conversion ratio of the flyback based converter is the highest.

The flyback based converter achieves high efficiency of 95%, which is more than that of the 91% and 92% of the boost and interleaved boost converters, respectively. Flyback based converter is subjected to low device stresses comparative to boost and interleaved boost converters. The flyback based converter has a MOSFET stress of 1560 W and total MOSFETs stress of 6,238.78 W. The boost converter has a MOSFET stress of 7,585 W and total MOSFETs stress of the same value. The interleaved boost converter has a MOSFET stress of 7,985 W and total MOSFETs stress of 15,970 W.

The MOSFET voltage stress of the flyback based converter is 40% of the output voltage while in the boost and interleaved boost converters is equal to the output voltage. The MOSFET current stress of flyback based converter is 10.31 A while in boost and interleaved converters is 20 A, equal to the input current. The number of MOSFET switches required in flyback based converter is 4 while in boost and interleaved boost converter is 1 and 2, respectively.

The conventional boost converter has a simple circuit as compared to flyback based and interleaved boost converter circuits. It is because of the parts count, which determines how much a circuit is complex. The higher the parts count, the smaller is the circuit complexity, which helps to understand the circuit easily.

The switch utilization in flyback based converter is higher than in the boost and interleaved boost converters. The converter cost is dependent on the cost of semiconductor devices. The semiconductor device cost is inversely related

TABLE II
ORCAD PSpice SIMULATION RESULTS OF FLYBACK BASED, INTERLEAVED BOOST, AND BOOST CONVERTERS

| Characteristics | Flyback based converter | Interleaved boost converter | Simple boost converter |
|---------------------|--------------------------------|--------------------------------|--------------------------------|
| Current Stress | Half of input current (10.31A) | Equal to input current (20A) | Equal to input current (20A) |
| Voltage Stress | Smallest (152) | Equal to output voltage (363V) | Equal to output voltage (363V) |
| Switch Stress | Smallest (1.56kW) | High (7.58kW) | Highest (7.98kW) |
| Total Switch Stress | Smallest (6.23kW) | High (7.58kW) | Highest (15.97kW) |
| Efficiency | Highest (95%) | Small (91%) | High (92%) |
| VCR | Highest (7.74) | High (7.55) | High (7.55) |
| Switch Utilization | Highest (15%) | High (12%) | Small (6%) |

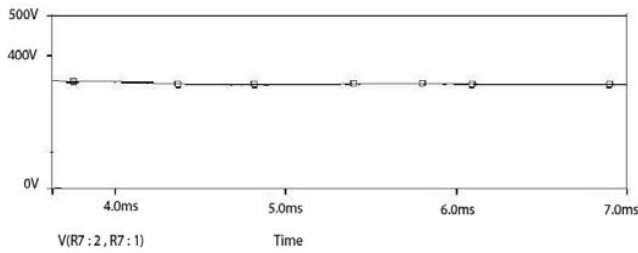

Fig. 3 Output voltage of flyback based converter

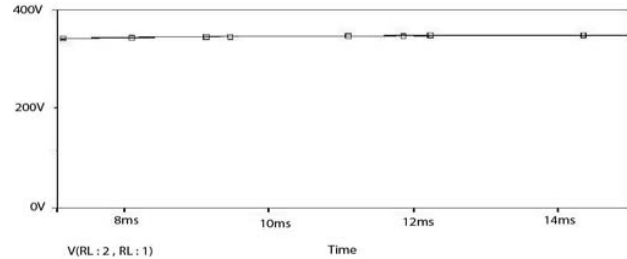

Fig. 6 Output voltage of interleaved boost converter

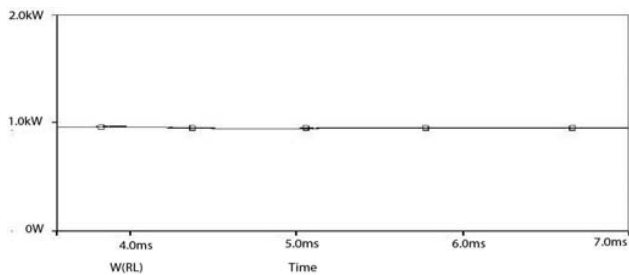

Fig. 4 Output power of flyback based converter

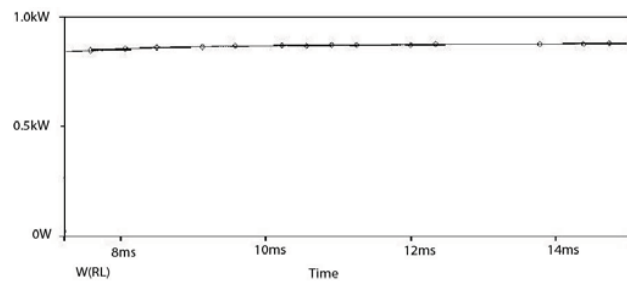

Fig. 7 Output power of interleaved boost converter

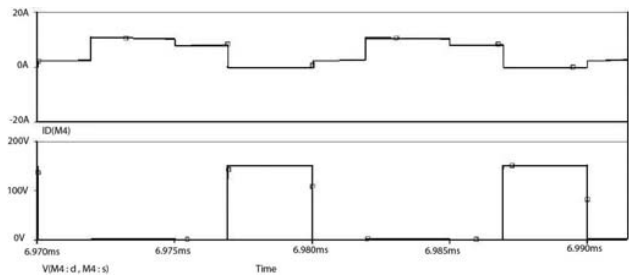

Fig. 5 Voltage and current stresses of flyback based converter

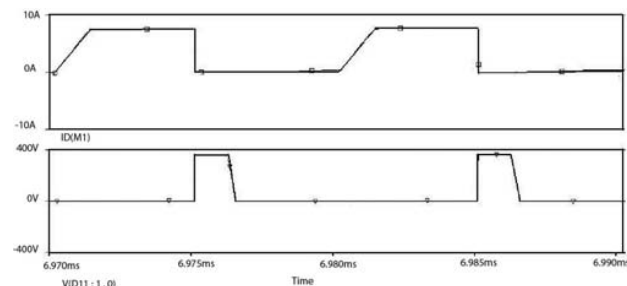

Fig. 8 Voltage and current stresses of interleaved boost converter

to the converter switch utilization. The converter switch utilization increases with the decrease of switch stresses. This means that converter of low device stresses reduces its cost. Good converter design has higher switch utilization. On the basis of comparison of characteristics of the converters, the flyback based converter is chosen as the most promising converter for low-voltage high-power applications.

VIII. CONCLUSIONS AND FUTURE WORK

Three DC-to-DC converters—flyback based, interleaved boost, and conventional boost converters have been analyzed

for low-voltage high-power renewable energy systems. The low voltage of 1 kW PV array has been increased to 380 volts DC, which is required for full bridge inverter to produce 220 volt AC for interfacing with 220 volt AC grid-connected power system. The candidate converters have been designed and then simulated in PSpice using semiconductor switches available in PSpice library.

Simulation results show that converters operate with high voltage conversion ratios. The results indicate that the

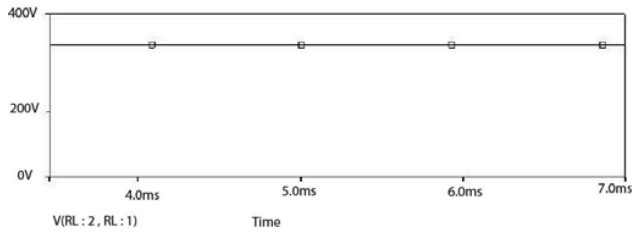

Fig. 9 Output voltage of boost converter

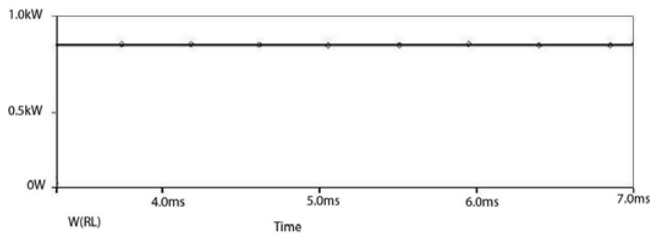

Fig. 10 Output power of boost converter

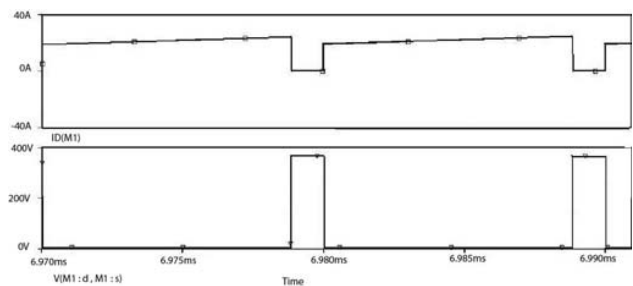

Fig. 11 Voltage and current stresses of boost converter

converters efficiently transfer the power from PV array to load. The simulation results suggest that the flyback based converter is the most appropriate converter to interface low-voltage PV arrays and fuel cell stacks to the 220 V AC utility grid through a 380 V full bridge inverter. It is because of the high voltage conversion ratio, high efficiency, low device stresses, and high switch utilization of the flyback based converter.

Our future work includes the AC small signal modeling and analysis of flyback based converter and interleaved boost converter to increase their accuracy.

ACKNOWLEDGMENT

The authors would like to thank Prof. Dr. Iftikhar Ahmad Khan for providing very useful suggestions, which have greatly improved quality of the research. We are also very thankful to the anonymous reviewers.

REFERENCES

- [1] R. Faranda, S. Leva, and V. Maugeri, "MPPT techniques for pv systems: Energetic and cost comparison," in *Power and Energy Society General Meeting - Conversion and Delivery of Electrical Energy in the 21st Century*, 2008 IEEE, July 2008, pp. 1–6.
- [2] R. Fiorello, "Powering a 35w DC metal halide high intensity discharge (hid) lamp using the ucc3305 hid lamp controller," *Unitrode Application Handbook U-161*, 1995.

- [3] J. Akerlund, "-48 v DC computer equipment topology-an emerging technology," in *Telecommunications Energy Conference, 1998. INTELEC. Twentieth International*, 1998, pp. 15–21.
- [4] L. Huber and M. Jovanovic, "A design approach for server power supplies for networking applications," in *Applied Power Electronics Conference and Exposition, 2000. APEC 2000. Fifteenth Annual IEEE*, vol. 2, 2000, pp. 1163–1169 vol.2.
- [5] J. Perkinson, "UPS systems: a review," in *Applied Power Electronics Conference and Exposition, 1988. APEC '88. Conference Proceedings 1988., Third Annual IEEE*, Feb 1988, pp. 151–154.
- [6] D. Oliveira, M. O. TA, and F. L. Tofoli, "A novel interleaved boost converter with high voltage gain for UPS applications," *Congresso Brasileiro de Eletrônica de Potência-COBEP*, 2007.
- [7] X. Huang, X. Wang, T. Nergaard, J.-S. Lai, X. Xu, and L. Zhu, "Parasitic ringing and design issues of digitally controlled high power interleaved boost converters," *Power Electronics, IEEE Transactions on*, vol. 19, no. 5, pp. 1341–1352, Sept 2004.
- [8] S. Jain and V. Agarwal, "A single-stage grid connected inverter topology for solar PV systems with maximum power point tracking," *Power Electronics, IEEE Transactions on*, vol. 22, no. 5, pp. 1928–1940, Sept 2007.
- [9] F. soon Kang, S. E. Cho, S.-J. Park, C.-U. Kim, and T. Ise, "A new control scheme of a cascaded transformer type multilevel {PWM} inverter for a residential photovoltaic power conditioning system," *Solar Energy*, vol. 78, no. 6, pp. 727 – 738, 2005.
- [10] T. Liang, Y. Kuo, and J. Chen, "Single-stage photovoltaic energy conversion system," *Electric Power Applications, IEE Proceedings -*, vol. 148, no. 4, pp. 339–344, Jul 2001.
- [11] Y. Chen and K. Smedley, "A cost-effective single-stage inverter with maximum power point tracking," *Power Electronics, IEEE Transactions on*, vol. 19, no. 5, pp. 1289–1294, Sept 2004.
- [12] C. Liu, A. Johnson, and J.-S. Lai, "A novel three-phase high-power soft switched dc/dc converter for low voltage fuel cell applications," vol. 3, pp. 1365–1371 Vol.3, 2004.
- [13] Q. Zhao and F. Lee, "High-efficiency, high step-up DC-DC converters," *Power Electronics, IEEE Transactions on*, vol. 18, no. 1, pp. 65–73, Jan 2003.
- [14] T. Liang and K. Tseng, "Analysis of integrated boost-flyback step-up converter," *Electric Power Applications, IEE Proceedings -*, vol. 152, no. 2, pp. 217–225, March 2005.
- [15] T. Dumrongkittigule, V. Tarateeraseth, and W. Khan-ngern, "A new integrated inductor with balanced switching technique for common mode emi reduction in high step-up DC/DC converter," in *Electromagnetic Compatibility, 2006. EMC-Zurich 2006. 17th International Zurich Symposium on*, Feb 2006, pp. 541–544.
- [16] K.-B. Park, H.-W. Seong, H.-S. Kim, G.-W. Moon, and M.-J. Youn, "Integrated boost-sepic converter for high step-up applications," in *Power Electronics Specialists Conference, 2008. PESC 2008. IEEE*, June 2008, pp. 944–950.
- [17] J.-W. Baek, M.-H. Ryoo, T.-J. Kim, D.-W. Yoo, and J.-S. Kim, "High boost converter using voltage multiplier," in *Industrial Electronics Society, 2005. IECON 2005. 31st Annual Conference of IEEE*, Nov 2005, pp. 6 pp.–.
- [18] J.-Y. Lee and S.-N. Hwang, "Non-isolated high-gain boost converter using voltage-stacking cell," *Electronics Letters*, vol. 44, no. 10, pp. 644–645, May 2008.
- [19] O. Krykunov, "Analysis of the extended forward converter for fuel cell applications," in *Industrial Electronics, 2007. ISIE 2007. IEEE International Symposium on*, June 2007, pp. 661–666.