

# Symbolic Analysis of Power Spectrum of CMOS Cross Couple Oscillator

Kittipong Tripetch

**Abstract**—This paper proposes for the first time symbolic formula of the power spectrum of CMOS Cross Couple Oscillator and its modified circuit. Many principles existed to derived power spectrum in microwave textbook such as impedance, admittance parameters, ABCD, H parameters, etc. It can be compared by graph of power spectrum which methodology is the best from the point of view of practical measurement setup such as condition of impedance parameter which used superposition of current to derived (its current injection at the other port of the circuit is zero, which is impossible in reality). Four graphs of impedance parameters of cross couple oscillator are proposed. After that four graphs of scattering parameters of CMOS cross coupled oscillator will be shown.

**Keywords**—Optimization, power spectrum, impedance parameter, scattering parameter.

## I. INTRODUCTION

THE power spectrum can be plotted with four types of scattering parameters, namely,  $S_{11}$  which is called input reflection coefficient,  $S_{12}$  which is called reverse power gain,  $S_{21}$  which is called forward power gain and  $S_{22}$  which is called output reflection coefficient. The scattering parameter was introduced to engineering communities before 1954 [1]. Scattering parameters can be derived based on two port circuit theory. It can be written as a ratio of voltage wave incident at port n. ( $V_n^+$ ) and voltage wave reflected at port n ( $V_n^-$ ). The conversion formulas from impedance parameters, admittance parameters and ABCD parameters to scattering parameters can be seen in textbook which is published since 1998 [2], [3].

## II. CMOS CROSS COUPLE EQUIVALENT CIRCUIT FOR IMPEDANCE PARAMETER DERIVATION

It is well known that the simplest circuit, which can implement sinusoidal oscillator is the circuit called CMOS cross-coupled oscillator [4], [5]. Its circuit can be described as a common source amplifier with parallel resonance circuit in cascading with another common source amplifier with parallel resonance circuit. The output of the second common source amplifier which is cascaded with the first common source amplifier at drain node is fed back to the gate terminal of the first common source amplifier without any additional bias circuit except two passive resistors which connects with positive supply voltage to drain terminal of both two cross coupled transistors.

Kittipong Tripetch is with the Graduate School of Science and Technology ia with the Department of Electronic and Electrical engineering, Keio University, Yokohama, Japan (Phone: 080-9573-3621; e-mail: kan1972@a2.keio.jp, Kittipong.tripetch.Mr@ieee.org ).

The small signal high frequency equivalent circuit is the most well-known methodology to derived small signal transfer function of any circuit. Its CMOS version has three to five parasitic capacitances per transistor and four terminal called drain, gate, source and bulk. So small signal parasitic capacitances can be reprinted here  $C_{gs}$ ,  $C_{gd}$ ,  $C_{db}$ ,  $C_{bs}$ , and  $C_{gb}$ . Usually, many textbooks in analog integrated circuit design have been use only three parasitic capacitances to derive symbolic formulas for any circuits but compared with Cadence Spectre, which have strange parasitic capacitances which are unknown in textbook. As a result, simulation results will not be the same.

The circuit in Fig. 1 is used to analyze symbolic formulas for power spectrum of the CMOS cross-coupled oscillator circuit.

The proposed figure included passive resistances, which can be seen as a probe for measurement. Another way to draw figure is using differential probe and differential signal generator. This circuit has four nodes but from the point of view of circuit analysis, its node needs Kirchoff's current law only two times at the drain nodes of MOSFET  $M_1$  and  $M_2$ .

The two equations can be listed here for reference below.

$$(V_1) \left( \frac{1}{R_{S1}} \right) + (V_{G1}) (sC_{gd1} + sC_{gd2} - g_{m1}) = (V_{G2}) \left( sC_{gs2} + g_{ds1} + \frac{1}{R_1} + \frac{1}{sL_1} + sC_1 + s(C_{gd1} + C_{gd2}) + \frac{1}{R_{S1}} \right) \quad (1)$$

$$(V_2) \left( \frac{1}{R_{S2}} \right) + V_{G2} [sC_{gd1} + sC_{gd2} - g_{m2}] = (V_{G1}) \left( sC_{gs1} + g_{ds2} + \frac{1}{R_{S2}} + sC_{gd2} + \frac{1}{R_2} + \frac{1}{sL_2} + s(C_2 + C_{gd1}) \right) \quad (2)$$

The other two equation which do not used KCL but it use Ohm's law can be written as following

$$I_{in1} = \frac{V_1 - V_{G2}}{R_{S1}} \rightarrow -V_1 + V_{G2} = -I_{in1} R_{S1} \quad (3)$$

$$I_{in2} = \frac{V_2 - V_{G1}}{R_{S2}} \rightarrow -V_2 + V_{G1} = -I_{in2} R_{S2} \quad (4)$$

The next step is to derive the impedance parameter is to write original matrix of the problem. We found that we need to write with the size matrix of 4 by 4. It can be written as following:

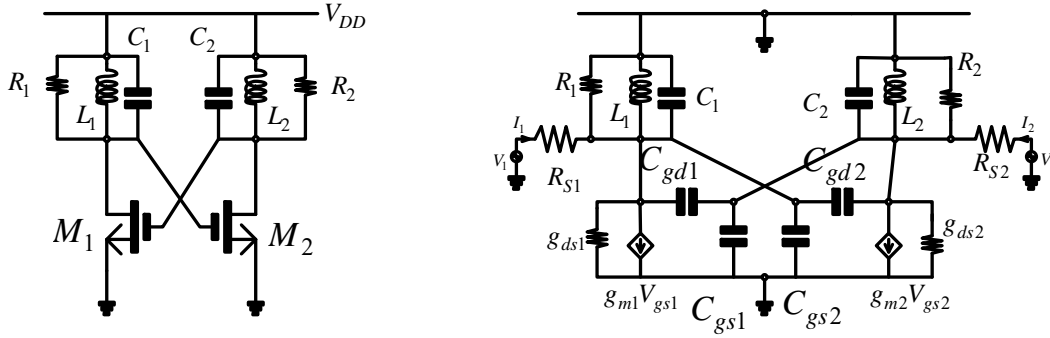

Fig. 1 Equivalent circuit of CMOS Cross couple oscillator

$$\begin{bmatrix} a_{11} & a_{12} & a_{13} & 0 \\ 0 & a_{22} & a_{23} & a_{24} \\ -1 & 0 & 1 & 0 \\ 0 & 1 & 0 & -1 \end{bmatrix} \begin{bmatrix} V_1 \\ V_{G1} \\ V_{G2} \\ V_2 \end{bmatrix} = \begin{bmatrix} 0 \\ 0 \\ -I_{in1}R_{S1} \\ -I_{in2}R_{S2} \end{bmatrix} \quad (5)$$

The symbolic coefficients from matrix of equation (5) can be compared with (1) and (2) and it can be rewritten here for convenience.

$$\begin{aligned} a_{11} &= \frac{1}{R_{S1}} \\ a_{12} &= s(C_{gd1} + C_{gd2}) - g_{m1} \\ a_{13} &= -\left[ s(C_{gs2} + C_{gd1} + C_{gd2} + C_1) + g_{ds1} + \frac{1}{R_1} + \frac{1}{R_{S1}} + \frac{1}{sL_1} \right] \\ a_{14} &= -\left[ sC_a + G_a + \frac{1}{sL_1} \right] \\ a_{22} &= s(C_{gs1} + C_{gd2} + C_2 + C_{gd1}) + g_{ds2} + \frac{1}{R_{S2}} + \frac{1}{R_2} + \frac{1}{sL_2} \\ a_{23} &= -s(C_{gd1} + C_{gd2}) + g_{m2} \\ a_{24} &= -\frac{1}{R_{S2}} \end{aligned} \quad (6)$$

in comparison with direct analysis from the small signal equivalent circuit. The author derived from 4 by 4 matrix the symbolic formulas of impedance parameters with full coefficients (16 coefficients) because of direct impedance analysis method from the circuit is not different from drive car along the road without map and label.

$$\begin{bmatrix} a_{11} & a_{12} & a_{13} & a_{14} \\ a_{21} & a_{22} & a_{23} & a_{24} \\ a_{31} & a_{32} & a_{33} & a_{34} \\ a_{41} & a_{42} & a_{43} & a_{44} \end{bmatrix} \begin{bmatrix} V_1 \\ V_{G1} \\ V_{G2} \\ V_2 \end{bmatrix} = \begin{bmatrix} 0 \\ 0 \\ -I_{in1}R_{S1} \\ -I_{in2}R_{S2} \end{bmatrix} \quad (8)$$

$$\begin{aligned} b_{12} &= \frac{a_{23} - \frac{a_{21}a_{13}}{a_{11}}}{a_{22} - \frac{a_{21}a_{12}}{a_{11}}} = \frac{a_{23}}{a_{22}} = \frac{-s^2(C_{gd1} + C_{gd2}) + sg_{m2}}{s^2C_b + sG_b + \frac{1}{L_2}} \\ b_{13} &= \frac{a_{24} - \frac{a_{21}a_{14}}{a_{11}}}{a_{22} - \frac{a_{21}a_{12}}{a_{11}}} = \frac{a_{24}}{a_{22}} = -\frac{s}{R_{S2} \left[ s^2C_b + sG_b + \frac{1}{L_2} \right]} \end{aligned} \quad (9)$$

where,  $b_{12}, b_{13}$  are intermediate coefficients which are used to make equation  $V_{G1} = f(V_{G2}, V_2)$  more compact so that it should be easy to visualize the whole equation which look shorter to represent within one line.

$$b_{22}V_{G2} + b_{23}V_2 = xI_{in1} \quad (10a)$$

$$b_{32}V_{G2} + b_{33}V_2 = yI_{in2} \quad (10b)$$

Complexity of the intermediate coefficients can be reduced by comparing (5) with (8). It can be seen that there are six coefficients, which have value equal with zero so that the intermediate coefficients can be reduced as following.

$$\begin{aligned} b_{22} &= \left( a_{33} - \frac{a_{31}a_{13}}{a_{11}} + b_{12} \left( a_{32} - \frac{a_{31}a_{12}}{a_{11}} \right) \right) = 1 - \frac{a_{31}a_{13}}{a_{11}} - \frac{b_{12}a_{31}a_{12}}{a_{11}} \\ b_{23} &= \left( a_{34} - \frac{a_{31}a_{14}}{a_{11}} + b_{13} \left( a_{32} - \frac{a_{31}a_{12}}{a_{11}} \right) \right) = -\frac{b_{13}a_{31}a_{12}}{a_{11}} \\ b_{32} &= \left( a_{43} - \frac{a_{41}a_{13}}{a_{11}} + b_{12} \left( a_{42} - \frac{a_{41}a_{12}}{a_{11}} \right) \right) = b_{12}a_{42} = b_{12} \\ b_{33} &= \left( a_{44} - \frac{a_{41}a_{14}}{a_{11}} + b_{13} \left( a_{42} - \frac{a_{41}a_{12}}{a_{11}} \right) \right) = b_{13}a_{42} = b_{13} \end{aligned} \quad (11)$$

where,  $b_{22}, b_{23}, b_{32}, b_{33}$  are intermediate coefficients which were used to make (11) more compact so that it should be easy to visualize the whole equation which is longer to represent within one line. From 2 port parameter definition in [3]

$$\begin{aligned} V_{in1} &= I_{in1}Z_{11} + I_{in2}Z_{12} \\ V_{in2} &= I_{in1}Z_{21} + I_{in2}Z_{22} \end{aligned} \quad (12)$$

From (10a), we can write  $V_{G2} = f(I_{in1}, V_{in2})$ , after that substitute it into (10b), we get;

$$\frac{V_{in2}}{I_{in2}} = Z_{22} = \frac{y}{b_{33} - \frac{b_{32}b_{23}}{b_{22}}} \quad (13)$$

$$\frac{V_{in2}}{I_{in1}} = Z_{21} = \frac{-xb_{32}}{b_{22} \left( b_{33} - \frac{b_{32}b_{23}}{b_{22}} \right)} = - \left( \frac{b_{32}}{b_{22}} \right) \left( \frac{x}{y} \right) Z_{22} \quad (14)$$

from two equation in the third row and fourth row of (8). That equation can be rewritten as;

$$\begin{aligned} a_{31}V_1 + a_{32}V_{G1} + a_{33}V_{G2} + a_{34}V_2 &= xI_{in1} \\ a_{41}V_1 + a_{42}V_{G1} + a_{43}V_{G2} + a_{44}V_2 &= yI_{in2} \end{aligned} \quad (15)$$

Then, someone can eliminate two variables so that we can write the next equation as

$$\begin{aligned} a_{31}V_1 + y_{32}V_2 &= x_2I_{in1} \\ a_{41}V_1 + x_3I_{in1} + y_{42}V_2 &= yI_{in2} \end{aligned} \quad (16)$$

Coefficients which appearing in (16) can be written as;

$$\begin{aligned} y_{32} &= a_{34} + a_{32}b_{13} - \left( \frac{b_{23}}{b_{22}} \right) (a_{33} + a_{32}b_{12}) = - \frac{b_{23}}{b_{22}} \\ y_{42} &= a_{44} + a_{42}b_{13} - \left( \frac{b_{23}}{b_{22}} \right) (a_{43} + a_{42}b_{12}) = -1 + b_{13} + d_{32}b_{12} \\ x_2 &= x \left( 1 - \frac{(a_{33} + a_{32}b_{12})}{b_{22}} \right) = x \left( 1 - \frac{1}{b_{22}} \right) \\ x_3 &= \frac{x(a_{43} + a_{42}b_{12})}{b_{22}} = \frac{xb_{12}}{b_{22}} \end{aligned} \quad (17)$$

Then, substituting (14)  $V_{in2} = Z_{21}I_{in1}$  into (16) and grouping the same variable  $I_{in1}$ , the other two impedance parameters can be derived as;

$$\begin{aligned} \frac{V_{in1}}{I_{in1}} &= \frac{x_2 - d_{32}Z_{21}}{a_{31}} = Z_{11} \\ \frac{V_{in1}}{I_{in2}} &= Z_{12} = \frac{yZ_{11}}{x_3 + y_{42}Z_{21}} \end{aligned} \quad (18)$$

The next step is to substitute small signal parameters from (6) and (7) into all intermediate coefficients in (9), (1) and (17), respectively.

Equation (11) can be written in polynomial form as;

$$\begin{aligned} b_{22} &= \frac{-s^4 a_4 + s^3 a_3 + s^2 a_2 + s a_1 + a_0}{s^3 L_1 C_b + s^2 L_1 G_b + s \left( \frac{L_1}{L_2} \right)} \\ a_4 &= R_{S1} L_1 C_a C_b + L_1 R_{S1} (C_{gd1} + C_{gd2})^2 \\ a_3 &= L_1 C_b + L_1 R_{S1} (C_{gd1} + C_{gd2}) (g_{m2} - g_{m1}) \\ &\quad - (L_1 C_a G_b + L_1 G_1 C_b) R_{S1} \end{aligned} \quad (19)$$

$$a_2 = L_1 G_b - L_1 R_{S1} g_{m2} g_{m1} - R_{S1} \left( \frac{L_1 C_a}{L_2} + C_b + L_1 G_a G_b \right)$$

$$a_1 = \left( \frac{L_1}{L_2} - R_{S1} \left( \frac{L_1 G_a}{L_2} + G_b \right) \right)$$

$$a_0 = - \frac{R_{S1}}{L_2}$$

$$b_{23} = \frac{\left( -s^2 L_2 (C_{gd1} + C_{gd2}) + s (L_2 g_{m1}) \right)}{\left( s^2 (L_2 C_b) + s (L_2 G_b) + 1 \right)} \quad (20)$$

$$b_{32} = \frac{-s^2 (C_{gd1} L_2 + C_{gd2} L_2) + s L_2 (g_{m2})}{s^2 (L_2 C_b) + s (L_2 G_b) + 1} \quad (21)$$

$$b_{33} = \frac{-s L_2}{s^2 (C_b R_{S2} L_2) + s (R_{S2} G_b L_2) + R_{S2}} \quad (22)$$

From (13), an impedance parameter ( $Z_{22}$ ) can be written as;

$$Z_{22} = \frac{50 R_{S2} \left( \frac{-s^6 c_{61} + s^5 c_{51} + s^4 c_{41}}{+s^3 c_{31} + s^2 c_{21} + s c_{11} + c_{01}} \right) \left( s^2 L_2 C_b + s L_2 G_b + 1 \right)}{s^7 (c_{72} - c_{73}) + s^6 (c_{62} - c_{63}) + s^5 (c_{52} - c_{53}) + s^4 (c_{42} - c_{43}) + s^3 (c_{32} - c_{33}) + s^2 (c_{22}) + s c_{12}} \quad (23)$$

$$c_{61} = a_4 L_2 C_b$$

$$c_{51} = a_3 L_2 C_b - a_4 L_2 G_b$$

$$c_{41} = a_3 L_2 G_b - a_4 + a_2 L_2 C_b$$

$$c_{31} = a_3 + a_2 L_2 G_b + a_1 L_2 C_b$$

$$c_{21} = a_2 + a_1 L_2 G_b + a_0 L_2 C_b$$

$$c_{11} = a_1 + a_0 L_2 G_b + a_0$$

$$c_{01} = a_0$$

$$c_{72} = L_2^2 C_b a_4$$

$$c_{62} = L_2 a_4 L_2 G_b - L_2 a_3 L_2 C_b$$

$$c_{52} = L_2 a_4 - L_2^2 a_3 G_b - L_2^2 a_2 C_b$$

$$c_{42} = -L_2 a_3 - L_2^2 a_2 G_b - L_2^2 a_1 C_b$$

$$c_{32} = -L_2 a_2 - L_2^2 a_1 G_b - L_2^2 a_0 C_b$$

$$c_{22} = -L_2 a_1 - L_2^2 a_0 G_b$$

$$c_{11} = -L_2 a_0$$

(24)

(25)

$$\begin{aligned}
 c_3 &= L_2^2 (C_{gd1} + C_{gd2})^2 \\
 c_2 &= 2L_2^2 (C_{gd1} + C_{gd2})(2g_{m2}) \\
 c_1 &= g_{m2}^2 L_2^2 \\
 c_{73} &= c_3 L_1 C_b R_{S2} \\
 c_{63} &= c_3 L_1 G_b R_{S2} - c_2 L_1 C_b R_{S2} \\
 c_{53} &= c_3 \left( \frac{L_1 R_{S2}}{L_2} \right) - c_2 L_1 G_b R_{S2} + c_1 L_1 C_b R_{S2} \\
 c_{43} &= - \left( \frac{c_2 L_1 R_{S2}}{L_2} \right) + c_1 L_1 G_b R_{S2} \\
 c_{33} &= \frac{c_1 L_1 R_{S2}}{L_2} \\
 Z_{22} &= \frac{50R_{S2} \begin{pmatrix} s^8 x_{81} + s^7 x_{71} + s^6 x_{61} + s^5 x_{51} \\ +s^4 x_{41} + s^3 x_{31} + s^2 x_{21} + s x_{11} + x_{01} \end{pmatrix}}{s^7 x_{72} + s^6 x_{62} + s^5 x_{52} + s^4 x_{42} + s^3 x_{32} + s^2 x_{22} + s x_{12}} \quad (27)
 \end{aligned}$$

$$\begin{aligned}
 x_{81} &= -c_{61} L_2 C_b \\
 x_{71} &= c_{51} L_2 C_b - c_{61} L_2 G_b \\
 x_{61} &= c_{41} L_2 C_b + c_{51} L_2 G_b - c_{61} \\
 x_{51} &= c_{31} L_2 C_b + c_{41} L_2 G_b + c_{51} \\
 x_{41} &= c_{21} L_2 C_b + c_{31} L_2 G_b + c_{41} \\
 x_{31} &= c_{11} L_2 C_b + c_{21} L_2 G_b + c_{31} \\
 x_{21} &= c_{01} L_2 C_b + c_{11} L_2 G_b + c_{21} \\
 x_{11} &= c_{11} + c_{01} L_2 G_b \\
 x_{01} &= c_{01} \\
 x_{72} &= c_{72} - c_{73} \\
 x_{62} &= c_{62} - c_{63} \\
 x_{52} &= c_{52} - c_{53} \\
 x_{42} &= c_{42} - c_{43} \\
 x_{32} &= c_{32} - c_{33} \\
 x_{22} &= c_{22} \\
 x_{12} &= c_{12}
 \end{aligned} \quad (28)$$

From (14), an impedance parameter ( $Z_{21}$ ) can be written as

$$Z_{21} = - \frac{\begin{pmatrix} -s^2 L_2 (C_{gd1} + C_{gd2}) \\ +s g_{m2} L_2 \\ -s^4 a_4 + s^3 a_3 + s^2 a_2 \\ +s a_1 + a_0 \end{pmatrix} 50R_{S2} \begin{pmatrix} s^8 c_{84} + s^7 c_{74} \\ +s^6 c_{64} + s^5 c_{54} \\ +s^4 c_{44} + s^3 c_{34} \\ +s^2 c_{24} + s c_{14} + c_{04} \end{pmatrix} \begin{pmatrix} s^3 L_1 C_b + s^2 L_1 G_b \\ +s \left( \frac{L_1}{L_2} \right) \end{pmatrix}}{\begin{pmatrix} s^7 (c_{72} - c_{73}) + s^6 (c_{62} - c_{63}) \\ +s^5 (c_{52} - c_{53}) + s^4 (c_{42} - c_{43}) \\ +s^3 (c_{32} - c_{33}) + s^2 c_{22} + s c_{12} \end{pmatrix} \begin{pmatrix} s^2 L_2 C_b \\ +s L_2 G_b + 1 \end{pmatrix}} \quad (29)$$

$$\begin{aligned}
 c_{84} &= -c_{61} L_2 C_b \\
 c_{74} &= c_{51} L_2 C_b - c_{61} L_2 G_b \\
 c_{64} &= c_{51} L_2 G_b - c_{61} + c_{41} L_2 C_b \\
 c_{54} &= c_{51} + c_{41} L_2 G_b + c_{31} L_2 C_b \\
 c_{44} &= c_{41} + c_{31} L_2 G_b + c_{21} L_2 C_b \\
 c_{34} &= c_{31} + c_{21} L_2 G_b + c_{11} L_2 C_b \\
 c_{24} &= c_{21} + c_{11} L_2 G_b + c_{01} L_2 C_b \\
 c_{14} &= c_{11} + c_{01} L_2 G_b \\
 c_{04} &= c_{01}
 \end{aligned} \quad (30)$$

$$Z_{21} = -50R_{S2} \frac{\begin{pmatrix} -s^2 L_2 (C_{gd1} + C_{gd2}) \\ +s g_{m2} L_2 \\ -s^4 a_4 + s^3 a_3 \\ +s^2 a_2 + s a_1 + a_0 \end{pmatrix} \begin{pmatrix} s^{11} c_{115} + s^{10} c_{105} + s^9 c_{95} \\ +s^8 c_{85} + s^7 c_{75} + s^6 c_{65} \\ +s^5 c_{55} + s^4 c_{45} + s^3 c_{35} \\ +s^2 c_{25} + s c_{15} \end{pmatrix}}{\begin{pmatrix} s^7 (c_{72} - c_{73}) \\ +s^6 (c_{62} - c_{63}) \\ +s^5 (c_{52} - c_{53}) \\ +s^4 (c_{42} - c_{43}) \\ +s^3 (c_{32} - c_{33}) \\ +s^2 c_{22} + s c_{12} \end{pmatrix} \begin{pmatrix} s^2 L_2 C_b \\ +s L_2 G_b + 1 \end{pmatrix}} \quad (31)$$

$$\begin{aligned}
 c_{115} &= c_{84} L_1 C_b \\
 c_{105} &= c_{84} L_1 G_b + c_{74} L_1 C_b \\
 c_{95} &= c_{84} \left( \frac{L_1}{L_2} \right) + c_{74} L_1 G_b + c_{64} L_1 C_b \\
 c_{85} &= c_{74} \left( \frac{L_1}{L_2} \right) + c_{64} L_1 G_b + c_{54} L_1 C_b \\
 c_{75} &= c_{64} \left( \frac{L_1}{L_2} \right) + c_{54} L_1 G_b + c_{44} L_1 C_b \\
 c_{65} &= c_{54} \left( \frac{L_1}{L_2} \right) + c_{44} L_1 G_b + c_{34} L_1 C_b \\
 c_{55} &= c_{44} \left( \frac{L_1}{L_2} \right) + c_{34} L_1 G_b + c_{24} L_1 C_b \\
 c_{45} &= c_{34} \left( \frac{L_1}{L_2} \right) + c_{24} L_1 G_b + c_{14} L_1 C_b \\
 c_{35} &= c_{24} \left( \frac{L_1}{L_2} \right) + c_{14} L_1 G_b + c_{04} L_1 C_b \\
 c_{25} &= c_{14} \left( \frac{L_1}{L_2} \right) + c_{04} L_1 G_b \\
 c_{15} &= c_{04} \left( \frac{L_1}{L_2} \right)
 \end{aligned} \quad (32)$$

$$Z_{21} = -50R_{S2} \frac{\begin{pmatrix} -s^2 L_2 (C_{gd1} + C_{gd2}) \\ +s g_{m2} L_2 \\ -s^4 a_4 + s^3 a_3 + s^2 a_2 \\ +s a_1 + a_0 \end{pmatrix} \begin{pmatrix} s^{11} c_{115} + s^{10} c_{105} + s^9 c_{95} \\ +s^8 c_{85} + s^7 c_{75} + s^6 c_{65} \\ +s^5 c_{55} + s^4 c_{45} + s^3 c_{35} \\ +s^2 c_{25} + s c_{15} \end{pmatrix}}{\begin{pmatrix} s^9 d_{91} + s^8 d_{81} + s^7 d_{71} + s^6 d_{61} \\ +s^5 d_{51} + s^4 d_{41} + s^3 d_{31} \\ +s^2 d_{21} + s d_{11} \end{pmatrix}} \quad (34)$$

$$\begin{aligned}
 d_{91} &= (c_{72} - c_{73})L_2C_b \\
 d_{81} &= (c_{62} - c_{63})L_2C_b + (c_{72} - c_{73})L_2G_b \\
 d_{71} &= (c_{72} - c_{73}) + (c_{62} - c_{63})L_2G_b + (c_{52} - c_{53})L_2C_b \\
 d_{61} &= (c_{62} - c_{63}) + (c_{52} - c_{53})L_2G_b + (c_{42} - c_{43})L_2C_b \\
 d_{51} &= (c_{52} - c_{53}) + (c_{42} - c_{43})L_2G_b + (c_{32} - c_{33}) \\
 d_{41} &= (c_{42} - c_{43}) + (c_{32} - c_{33})L_2G_b + c_{22}L_2C_b \\
 d_{31} &= (c_{32} - c_{33}) + (c_{22})L_2G_b + c_{12}L_2C_b \\
 d_{21} &= c_{22} + c_{12}L_2G_b \\
 d_{11} &= c_{12}
 \end{aligned} \tag{35}$$

The polynomial form of (14) can be written as;

$$Z_{21} = -50R_{S2} \begin{pmatrix} s^{13}d_{132} + s^{12}d_{122} + s^{11}d_{112} \\ +s^{10}d_{102} + s^9d_{92} + s^8d_{82} \\ +s^7d_{72} + s^6d_{62} + s^5d_{52} \\ +s^4d_{42} + s^3d_{32} + s^2d_{22} \\ s^{13}d_{133} + s^{12}d_{123} + s^{11}d_{113} \\ +s^{10}d_{103} + s^9d_{93} + s^8d_{83} \\ +s^7d_{73} + s^6d_{63} + s^5d_{53} \\ +s^4d_{43} + s^3d_{33} + s^2d_{23} + sd_{13} \end{pmatrix} \tag{36}$$

$$\begin{aligned}
 d_{132} &= L_2(C_{gd1} + C_{gd2})c_{115} \\
 d_{122} &= g_{m2}L_2c_{115} - L_2(C_{gd1} + C_{gd2})c_{105} \\
 d_{112} &= g_{m2}L_2c_{105} - L_2(C_{gd1} + C_{gd2})c_{95} \\
 d_{102} &= g_{m2}L_2c_{95} - L_2(C_{gd1} + C_{gd2})c_{85} \\
 d_{92} &= g_{m2}L_2c_{85} - L_2(C_{gd1} + C_{gd2})c_{75} \\
 d_{82} &= g_{m2}L_2c_{75} - L_2(C_{gd1} + C_{gd2})c_{65} \\
 d_{72} &= g_{m2}L_2c_{65} - L_2(C_{gd1} + C_{gd2})c_{55} \\
 d_{62} &= g_{m2}L_2c_{55} - L_2(C_{gd1} + C_{gd2})c_{45} \\
 d_{52} &= g_{m2}L_2c_{45} - L_2(C_{gd1} + C_{gd2})c_{35} \\
 d_{42} &= g_{m2}L_2c_{35} - L_2(C_{gd1} + C_{gd2})c_{25} \\
 d_{32} &= g_{m2}L_2c_{25} - L_2(C_{gd1} + C_{gd2})c_{15} \\
 d_{22} &= g_{m2}L_2c_{15}
 \end{aligned} \tag{37}$$

$$\begin{aligned}
 d_{133} &= -a_4d_{91} \\
 d_{123} &= a_3d_{91} - a_4d_{81} \\
 d_{113} &= a_3d_{81} - a_4d_{71} + a_2d_{91} \\
 d_{103} &= -a_4d_{61} + a_3d_{71} + a_2d_{81} + a_1d_{91} \\
 d_{93} &= -a_4d_{51} + a_3d_{61} + a_2d_{71} + a_1d_{81} + a_0d_{91} \\
 d_{83} &= -a_4d_{41} + a_3d_{51} + a_2d_{61} + a_1d_{71} + a_0d_{81} \\
 d_{73} &= -a_4d_{31} + a_3d_{41} + a_2d_{51} + a_1d_{61} + a_0d_{71} \\
 d_{63} &= -a_4d_{21} + a_3d_{31} + a_2d_{41} + a_1d_{51} + a_0d_{61} \\
 d_{53} &= -a_4d_{11} + a_3d_{21} + a_2d_{31} + a_1d_{41} + a_0d_{51} \\
 d_{43} &= a_3d_{11} + a_2d_{21} + a_1d_{31} + a_0d_{41} \\
 d_{33} &= a_2d_{11} + a_1d_{21} + a_0d_{31} \\
 d_{23} &= a_1d_{11} + a_0d_{21} \\
 d_{13} &= a_1d_{11}
 \end{aligned} \tag{38}$$

The polynomial form of (17) can be written as;

$$y_{32} = -\frac{b_{23}}{b_{22}} = \frac{\left( \frac{-s^2L_2(C_{gd1} + C_{gd2}) + s(L_2g_{m1})}{s^2(L_2C_b) + s(L_2G_b) + 1} \right)}{\left( \frac{-s^4a_4 + s^3a_3 + s^2a_2 + sa_1 + a_0}{s^3L_1C_b + s^2L_1G_b + s\left(\frac{L_1}{L_2}\right)} \right)} \tag{39}$$

$$y_{32} = -\frac{\left( s^5f_{51} + s^4f_{41} + s^3f_{31} + s^2f_{21} \right)}{\left( s^6f_{62} + s^5f_{52} + s^4f_{42} + s^3f_{32} + s^2f_{22} + sf_{12} + f_{02} \right)} \tag{40}$$

$$\begin{aligned}
 f_{51} &= -L_2L_1C_b(C_{gd1} + C_{gd2}) \\
 f_{41} &= L_1L_2g_{m1}C_b - L_2L_1(C_{gd1} + C_{gd2})G_b
 \end{aligned} \tag{41}$$

$$\begin{aligned}
 f_{31} &= L_1L_2g_{m1}G_b - L_1(C_{gd1} + C_{gd2}) \\
 f_{21} &= L_1g_{m1}
 \end{aligned}$$

$$\begin{aligned}
 f_{62} &= -a_4L_2C_b \\
 f_{52} &= a_3L_2C_b - a_4L_2G_b
 \end{aligned} \tag{42}$$

$$\begin{aligned}
 f_{42} &= a_2L_2C_b + a_3L_2G_b - a_4 \\
 f_{32} &= a_3 + a_2L_2G_b + a_1L_2C_b
 \end{aligned}$$

$$\begin{aligned}
 f_{22} &= a_2 + a_1L_2G_b + a_0L_2C_b \\
 f_{12} &= a_1 + a_0L_2G_b
 \end{aligned}$$

$$\begin{aligned}
 f_{02} &= a_0 \\
 y_{42} &= -1 + b_{13} + y_{32}b_{12} = -1 - \frac{s}{R_{S2} \left[ s^2C_b + sG_b + \frac{1}{L_2} \right]}
 \end{aligned} \tag{43}$$

$$\begin{aligned}
 &+ \left( \frac{\left( s^5f_{51} + s^4f_{41} + s^3f_{31} + s^2f_{21} \right)}{\left( s^6f_{62} + s^5f_{52} + s^4f_{42} + s^3f_{32} \right)} \right) \left( \frac{-s^2(C_{gd1} + C_{gd2}) + sg_{m2}}{s^2C_b + sG_b + \frac{1}{L_2}} \right) \\
 &- \left( \frac{\left( s^8f_{83} + s^7f_{73} + s^6f_{63} + s^5f_{53} + s^4f_{43} \right)}{\left( s^3f_{33} + s^2f_{23} + sf_{13} + f_{03} \right)} \right) R_{S2} \\
 &- \left( s^7f_{74} + s^6f_{64} + s^5f_{54} + s^4f_{44} + s^3f_{34} + s^2f_{24} + sf_{14} \right)
 \end{aligned}$$

$$y_{42} = \frac{-\left( s^7f_{75} + s^6f_{65} + s^5f_{55} + s^4f_{45} + s^3f_{35} \right)}{\left( s^8f_{83} + s^7f_{73} + s^6f_{63} + s^5f_{53} + s^4f_{43} \right)} \tag{44}$$

$$\begin{aligned}
 f_{83} &= (f_{62}C_bL_2) \\
 f_{73} &= (f_{62}G_bL_2 + f_{52}C_bL_2) \\
 f_{63} &= (f_{62} + f_{52}G_bL_2 + f_{42}C_bL_2) \\
 f_{53} &= (f_{52} + f_{42}G_bL_2 + f_{32}C_bL_2) \\
 f_{43} &= (f_{42} + f_{32}G_bL_2 + f_{22}C_bL_2) \\
 f_{33} &= (f_{32} + f_{22}G_bL_2 + f_{12}C_bL_2) \\
 f_{23} &= (f_{22} + f_{12}G_bL_2 + f_{02}C_bL_2) \\
 f_{13} &= (f_{12} + f_{02}G_bL_2 +) \\
 f_{03} &= f_{02}
 \end{aligned} \tag{45}$$

$$\begin{aligned}
 f_{74} &= L_2f_{62}R_{S2}, f_{64} = L_2f_{52}R_{S2}, f_{54} = L_2f_{42}R_{S2} \\
 f_{44} &= L_2f_{32}R_{S2}, f_{34} = L_2f_{22}R_{S2}, f_{24} = L_2f_{12}R_{S2} \\
 f_{14} &= L_2f_{02}R_{S2}
 \end{aligned} \tag{46}$$

$$\begin{aligned}
 f_{75} &= -f_{51}(C_{gd1} + C_{gd2})L_2R_{S2} \\
 f_{65} &= (f_{51}g_{m2}L_2 - f_{41}(C_{gd1} + C_{gd2})L_2)R_{S2} \\
 f_{55} &= (f_{41}g_{m2}L_2 - f_{31}(C_{gd1} + C_{gd2})L_2)R_{S2} \\
 f_{45} &= (f_{31}g_{m2}L_2 - f_{21}(C_{gd1} + C_{gd2})L_2)R_{S2} \\
 f_{35} &= (f_{21}g_{m2}L_2)R_{S2}
 \end{aligned}$$

(47)

$$x_2 = -50 \left( \frac{\begin{pmatrix} -s^4 a_4 + s^3 (a_3 - L_1 C_b) \\ +s^2 (a_2 - L_1 G_b) + s \left( a_1 - \frac{L_1}{L_2} \right) + a_0 \end{pmatrix}}{-s^4 a_4 + s^3 a_3 + s^2 a_2 + s a_1 + a_0} \right) \quad (51)$$

$$y_{42} = \frac{\begin{pmatrix} s^8 f_{83} R_{S2} + s^7 (f_{73} R_{S2} + f_{74} + f_{75}) \\ +s^6 (f_{63} R_{S2} + f_{64} + f_{65}) \\ +s^5 (f_{53} R_{S2} + f_{54} + f_{55}) \\ -s^4 (f_{43} R_{S2} + f_{44} + f_{45}) \\ +s^3 (f_{33} R_{S2} + f_{34} + f_{35}) \\ +s^2 (f_{23} R_{S2} + f_{24}) \\ +s (f_{13} R_{S2} + f_{14}) + f_{03} R_{S2} \end{pmatrix}}{\begin{pmatrix} s^8 f_{83} + s^7 f_{73} + s^6 f_{63} + s^5 f_{53} + s^4 f_{43} \\ +s^3 f_{33} + s^2 f_{23} + s f_{13} + f_{03} \end{pmatrix}}$$

(48.a)

$$x_3 = -50 \left( \frac{b_{12}}{b_{22}} \right) = -50 \left( \frac{\begin{pmatrix} -s^2 (C_{gd1} + C_{gd2}) + s g_{m2} \\ s^2 C_b + s G_b + \frac{1}{L_2} \end{pmatrix}}{\begin{pmatrix} -s^4 a_4 + s^3 a_3 + s^2 a_2 + s a_1 + a_0 \\ s^3 L_1 C_b + s^2 L_1 G_b + s \left( \frac{L_1}{L_2} \right) \end{pmatrix}} \right) \quad (52)$$

Multiply both sides of (52) with

$$\begin{aligned}
 &\left( s^2 C_b + s G_b + \frac{1}{L_2} \right) \left( s^3 L_1 C_b + s^2 L_1 G_b + s \left( \frac{L_1}{L_2} \right) \right) \\
 x_3 &= -50 \left( \frac{\begin{pmatrix} -s^2 (C_{gd1} + C_{gd2}) + s g_{m2} \\ (-s^4 a_4 + s^3 a_3 + s^2 a_2 + s a_1 + a_0) \left( s^2 C_b + s G_b + \frac{1}{L_2} \right) \end{pmatrix}}{\begin{pmatrix} s^3 L_1 C_b + s^2 L_1 G_b + s \left( \frac{L_1}{L_2} \right) \end{pmatrix}} \right) \quad (53)
 \end{aligned}$$

(48.b)

$$x_3 = \frac{-50 (s^5 g_{51} + s^4 g_{41} + s^3 g_{31} + s^2 g_{21})}{(s^6 g_{62} + s^5 g_{52} + s^4 g_{42} + s^3 g_{32} + s^2 g_{22} + s g_{12} + g_{02})} \quad (54)$$

$$\begin{aligned}
 f_{86} &= f_{83} R_{S2} \\
 f_{76} &= f_{73} R_{S2} + f_{74} + f_{75} \\
 f_{66} &= f_{63} R_{S2} + f_{64} + f_{65} \\
 f_{56} &= f_{53} R_{S2} + f_{54} + f_{55} \\
 f_{46} &= f_{43} R_{S2} + f_{44} + f_{45} \\
 f_{36} &= f_{33} R_{S2} + f_{34} + f_{35} \\
 f_{26} &= f_{23} R_{S2} + f_{24} \\
 f_{16} &= f_{13} R_{S2} + f_{14} \\
 f_{06} &= f_{03} R_{S2}
 \end{aligned}$$

Equation can be written in compact form as

$$y_{42} = \frac{\begin{pmatrix} s^8 f_{86} + s^7 f_{76} + s^6 f_{66} + s^5 f_{56} \\ +s^4 f_{46} + s^3 f_{36} + s^2 f_{26} + s f_{16} + f_{06} \end{pmatrix}}{\begin{pmatrix} s^8 f_{83} + s^7 f_{73} + s^6 f_{63} + s^5 f_{53} + s^4 f_{43} \\ +s^3 f_{33} + s^2 f_{23} + s f_{13} + f_{03} \end{pmatrix}}$$

(48.c)

$$x_2 = -50 \left( \frac{b_{22} - 1}{b_{22}} \right) = -50 \left( \frac{\begin{pmatrix} -s^4 a_4 + s^3 a_3 + s^2 a_2 \\ +s a_1 + a_0 \end{pmatrix} \left( \frac{s^3 L_1 C_b + s^2 L_1 G_b + s \left( \frac{L_1}{L_2} \right)}{s^3 L_1 C_b + s^2 L_1 G_b + s \left( \frac{L_1}{L_2} \right)} \right) - 1}{\begin{pmatrix} -s^4 a_4 + s^3 a_3 + s^2 a_2 \\ +s a_1 + a_0 \end{pmatrix} \left( \frac{s^3 L_1 C_b + s^2 L_1 G_b + s \left( \frac{L_1}{L_2} \right)}{s^3 L_1 C_b + s^2 L_1 G_b + s \left( \frac{L_1}{L_2} \right)} \right)} \right) \quad (49)$$

Multiply both sides of (49) with

$$\begin{aligned}
 &s^3 L_1 C_b + s^2 L_1 G_b + s \left( \frac{L_1}{L_2} \right) \\
 x_2 &= -50 \left( \frac{\begin{pmatrix} -s^4 a_4 + s^3 a_3 + s^2 a_2 \\ +s a_1 + a_0 \end{pmatrix} \left( \frac{s^3 L_1 C_b + s^2 L_1 G_b + s \left( \frac{L_1}{L_2} \right)}{s^3 L_1 C_b + s^2 L_1 G_b + s \left( \frac{L_1}{L_2} \right)} \right) - \left( s^3 L_1 C_b + s^2 L_1 G_b + s \left( \frac{L_1}{L_2} \right) \right)}{-s^4 a_4 + s^3 a_3 + s^2 a_2 + s a_1 + a_0} \right) \quad (50)
 \end{aligned}$$

$$\begin{aligned}
 g_{51} &= -(C_{gd1} + C_{gd2})L_1 C_b \\
 g_{41} &= (g_{m2}L_1 C_b) - (C_{gd1} + C_{gd2})L_1 G_b \\
 g_{31} &= (L_1 G_b g_{m2}) - (C_{gd1} + C_{gd2}) \left( \frac{L_1}{L_2} \right) \\
 g_{21} &= g_{m2} \left( \frac{L_1}{L_2} \right)
 \end{aligned} \quad (55)$$

$$\begin{aligned}
 g_{62} &= -a_4 C_b \\
 g_{52} &= a_3 C_b - a_4 G_b \\
 g_{42} &= a_3 G_b - \left( \frac{a_4}{L_2} \right) + a_2 C_b \\
 g_{32} &= \left( \frac{a_3}{L_2} \right) + a_2 G_b + a_1 C_b \\
 g_{22} &= \left( \frac{a_2}{L_2} \right) + a_1 G_b + a_0 C_b \\
 g_{12} &= \left( \frac{a_1}{L_2} \right) + a_0 G_b \\
 g_{02} &= \left( \frac{a_0}{L_2} \right)
 \end{aligned} \quad (56)$$

After substitute polynomial form from (40), (36) and (51) into (18), it can be written as;

$$Z_{11} = y_{32}Z_{21} - x_2 \tag{57}$$

$$Z_{11} = \frac{50R_{S2} \begin{pmatrix} s^{18}g_{183} + s^{17}g_{173} + s^{16}g_{163} + s^{15}g_{153} + s^{14}g_{143} + s^{13}g_{133} \\ + s^{12}g_{123} + s^{11}g_{113} + s^{10}g_{103} + s^9g_{93} + s^8g_{83} + s^7g_{73} \\ + s^6g_{63} + s^5g_{53} + s^4g_{43} \end{pmatrix}}{\begin{pmatrix} s^{19}g_{194} + s^{18}g_{184} + s^{17}g_{174} + s^{16}g_{164} + s^{15}g_{154} + s^{14}g_{144} \\ + s^{13}g_{134} + s^{12}g_{124} + s^{11}g_{114} + s^{10}g_{104} + s^9g_{94} + s^8g_{84} \\ + s^7g_{74} + s^6g_{64} + s^5g_{54} + s^4g_{44} + s^3g_{34} + s^2g_{24} + sg_{14} \end{pmatrix}} \tag{58}$$

$$\begin{aligned} g_{183} &= f_{51}d_{132} \\ g_{173} &= f_{51}d_{122} + f_{41}d_{132} \\ g_{163} &= f_{31}d_{132} + f_{41}d_{122} + f_{51}d_{112} \\ g_{153} &= f_{21}d_{132} + f_{31}d_{122} + f_{41}d_{112} + f_{51}d_{102} \\ g_{143} &= f_{21}d_{122} + f_{31}d_{112} + f_{41}d_{102} + f_{51}d_{92} \\ g_{133} &= f_{21}d_{112} + f_{31}d_{102} + f_{41}d_{92} + f_{51}d_{82} \\ g_{123} &= f_{21}d_{102} + f_{31}d_{92} + f_{41}d_{82} + f_{51}d_{72} \\ g_{113} &= f_{21}d_{92} + f_{31}d_{82} + f_{41}d_{72} + f_{51}d_{62} \\ g_{103} &= f_{21}d_{82} + f_{31}d_{72} + f_{41}d_{62} + f_{51}d_{52} \\ g_{93} &= f_{21}d_{72} + f_{31}d_{62} + f_{41}d_{52} + f_{51}d_{42} \\ g_{83} &= f_{21}d_{62} + f_{31}d_{52} + f_{41}d_{42} + f_{51}d_{32} \\ g_{73} &= f_{21}d_{52} + f_{31}d_{42} + f_{41}d_{32} + f_{51}d_{22} \\ g_{63} &= f_{21}d_{42} + f_{31}d_{32} + f_{41}d_{22} \\ g_{53} &= f_{21}d_{32} + f_{31}d_{22} \\ g_{43} &= f_{21}d_{22} \end{aligned} \tag{59}$$

$$\begin{aligned} h_{211} &= d_{132}f_{83} \\ h_{201} &= d_{122}f_{83} + d_{132}f_{73} \\ h_{191} &= d_{112}f_{83} + d_{122}f_{73} + d_{132}f_{63} \\ h_{181} &= d_{132}f_{53} + d_{122}f_{63} + d_{112}f_{73} + d_{102}f_{83} \\ h_{171} &= d_{132}f_{43} + d_{122}f_{53} + d_{112}f_{63} + d_{102}f_{73} + d_{92}f_{83} \\ h_{161} &= d_{132}f_{33} + d_{122}f_{43} + d_{112}f_{53} + d_{102}f_{63} + d_{92}f_{73} + d_{82}f_{83} \\ h_{151} &= d_{132}f_{23} + d_{122}f_{33} + d_{112}f_{43} + d_{102}f_{53} + d_{92}f_{63} + d_{82}f_{73} + d_{72}f_{83} \\ h_{141} &= f_{132}f_{13} + d_{122}f_{23} + d_{112}f_{33} + d_{102}f_{43} + d_{92}f_{53} + d_{82}f_{63} + d_{72}f_{73} + d_{62}f_{83} \\ h_{131} &= d_{132}f_{03} + d_{122}f_{13} + d_{112}f_{23} + d_{102}f_{33} + d_{92}f_{43} + d_{82}f_{53} + d_{72}f_{63} + d_{62}f_{73} + d_{52}f_{83} \\ h_{121} &= d_{122}f_{03} + d_{112}f_{13} + d_{102}f_{23} + d_{92}f_{33} + d_{82}f_{43} + d_{72}f_{53} + d_{62}f_{63} + d_{52}f_{73} + d_{42}f_{83} \\ h_{111} &= d_{112}f_{03} + d_{102}f_{13} + d_{92}f_{23} + d_{82}f_{33} + d_{72}f_{43} + d_{62}f_{53} + d_{52}f_{63} + d_{42}f_{73} + d_{32}f_{83} \\ h_{101} &= d_{102}f_{03} + d_{92}f_{13} + d_{82}f_{23} + d_{72}f_{33} + d_{62}f_{43} + d_{52}f_{53} + d_{42}f_{63} + d_{32}f_{73} + d_{22}f_{83} \\ h_{91} &= d_{92}f_{03} + d_{82}f_{13} + d_{72}f_{23} + d_{62}f_{33} + d_{52}f_{43} + d_{42}f_{53} + d_{32}f_{63} + d_{22}f_{73} \\ h_{81} &= d_{82}f_{03} + d_{72}f_{13} + d_{62}f_{23} + d_{52}f_{33} + d_{42}f_{43} + d_{32}f_{53} + d_{22}f_{63} \\ h_{71} &= d_{72}f_{03} + d_{62}f_{13} + d_{52}f_{23} + d_{42}f_{33} + d_{32}f_{43} + d_{22}f_{53} \\ h_{61} &= d_{62}f_{03} + d_{52}f_{13} + d_{42}f_{23} + d_{32}f_{33} + d_{22}f_{43} \\ h_{51} &= d_{52}f_{03} + d_{42}f_{13} + d_{32}f_{23} + d_{22}f_{33} \\ h_{41} &= d_{42}f_{03} + d_{32}f_{13} + d_{22}f_{23} \\ h_{31} &= d_{32}f_{03} + d_{22}f_{13} \\ h_{21} &= d_{22}f_{03} \end{aligned} \tag{62}$$

$$\begin{aligned} g_{194} &= f_{62}d_{133} \\ g_{184} &= f_{52}d_{133} + f_{62}d_{123} \\ g_{174} &= f_{42}d_{133} + f_{52}d_{123} + f_{62}d_{113} \\ g_{164} &= f_{32}d_{133} + f_{42}d_{123} + f_{52}d_{113} \\ g_{154} &= f_{22}d_{133} + f_{32}d_{123} + f_{42}d_{113} + f_{52}d_{103} + f_{62}d_{93} \\ g_{144} &= f_{12}d_{133} + f_{22}d_{123} + f_{32}d_{113} + f_{42}d_{103} + f_{52}d_{93} + f_{62}d_{83} \\ g_{134} &= f_{02}d_{133} + f_{12}d_{123} + f_{22}d_{113} + f_{32}d_{103} + f_{42}d_{93} + f_{52}d_{83} + f_{62}d_{73} \\ g_{124} &= f_{02}d_{123} + f_{12}d_{113} + f_{22}d_{103} + f_{32}d_{93} + f_{42}d_{83} + f_{52}d_{73} + f_{62}d_{63} \\ g_{114} &= f_{02}d_{113} + f_{12}d_{103} + f_{22}d_{93} + f_{32}d_{83} + f_{42}d_{73} + f_{52}d_{63} + f_{62}d_{53} \\ g_{104} &= f_{02}d_{103} + f_{12}d_{93} + f_{22}d_{83} + f_{32}d_{73} + f_{42}d_{63} + f_{52}d_{53} + f_{62}d_{43} \\ g_{94} &= f_{02}d_{93} + f_{12}d_{83} + f_{22}d_{73} + f_{32}d_{63} + f_{42}d_{53} + f_{52}d_{43} + f_{62}d_{33} \\ g_{84} &= f_{02}d_{83} + f_{12}d_{73} + f_{22}d_{63} + f_{32}d_{53} + f_{42}d_{43} + f_{52}d_{33} + f_{62}d_{23} \\ g_{74} &= f_{02}d_{73} + f_{12}d_{63} + f_{22}d_{53} + f_{32}d_{43} + f_{42}d_{33} + f_{52}d_{23} + f_{62}d_{13} \\ g_{64} &= f_{02}d_{63} + f_{12}d_{53} + f_{22}d_{43} + f_{32}d_{33} + f_{42}d_{23} + f_{52}d_{13} \\ g_{54} &= f_{02}d_{53} + f_{12}d_{43} + f_{22}d_{33} + f_{32}d_{23} + f_{42}d_{13} \\ g_{44} &= f_{02}d_{43} + f_{12}d_{33} + f_{22}d_{23} + f_{32}d_{13} \\ g_{34} &= f_{02}d_{33} + f_{12}d_{23} + f_{22}d_{13} \\ g_{24} &= f_{02}d_{23} + f_{12}d_{13} \\ g_{14} &= f_{02}d_{13} \end{aligned} \tag{60}$$

After substitute polynomial form from (36), (44) and (54) and (58) into (18), it can be written as;

$$\frac{V_{in1}}{I_{in2}} = Z_{12} = \frac{yZ_{11}}{x_3 + y_{42}Z_{21}} = \frac{-50Z_{11}}{x_3 + y_{42}Z_{21}} \tag{61}$$

$$\begin{aligned}
 h_{272} &= h_{211}g_{62} \\
 h_{262} &= h_{211}g_{52} + h_{201}g_{62} \\
 h_{252} &= h_{211}g_{42} + h_{201}g_{52} + h_{191}g_{62} \\
 h_{242} &= h_{211}g_{32} + h_{201}g_{42} + h_{191}g_{52} + h_{181}g_{62} \\
 h_{232} &= h_{211}g_{22} + h_{201}g_{32} + h_{191}g_{42} + h_{181}g_{52} + h_{171}g_{62} \\
 h_{222} &= h_{211}g_{12} + h_{201}g_{22} + h_{191}g_{32} + h_{181}g_{42} + h_{171}g_{52} + h_{161}g_{62} \\
 h_{212} &= h_{211}g_{02} + h_{201}g_{12} + h_{191}g_{22} + h_{181}g_{32} + h_{171}g_{42} + h_{161}g_{52} + h_{151}g_{62} \\
 h_{202} &= h_{201}g_{02} + h_{191}g_{12} + h_{181}g_{22} + h_{171}g_{32} + h_{161}g_{42} + h_{151}g_{52} + h_{141}g_{62} \\
 h_{192} &= h_{191}g_{02} + h_{181}g_{12} + h_{171}g_{22} + h_{161}g_{32} + h_{151}g_{42} + h_{141}g_{52} + h_{131}g_{62} \\
 h_{182} &= h_{181}g_{02} + h_{171}g_{12} + h_{161}g_{22} + h_{151}g_{32} + h_{141}g_{42} + h_{131}g_{52} + h_{21}g_{62} \\
 h_{172} &= h_{171}g_{02} + h_{161}g_{12} + h_{151}g_{22} + h_{141}g_{32} + h_{131}g_{42} + h_{21}g_{52} + h_{111}g_{62} \\
 h_{162} &= h_{161}g_{02} + h_{151}g_{12} + h_{141}g_{22} + h_{131}g_{32} + h_{121}g_{42} + h_{111}g_{52} + h_{01}g_{62} \\
 h_{152} &= h_{151}g_{02} + h_{141}g_{12} + h_{131}g_{22} + h_{121}g_{32} + h_{111}g_{42} + h_{01}g_{52} + h_{91}g_{62} \\
 h_{142} &= h_{141}g_{02} + h_{131}g_{12} + h_{121}g_{22} + h_{111}g_{32} + h_{01}g_{42} + h_{91}g_{52} + h_{81}g_{62} \\
 h_{132} &= h_{131}g_{02} + h_{121}g_{12} + h_{111}g_{22} + h_{01}g_{32} + h_{91}g_{42} + h_{81}g_{52} + h_{71}g_{62} \\
 h_{122} &= h_{121}g_{02} + h_{111}g_{12} + h_{01}g_{22} + h_{91}g_{32} + h_{81}g_{42} + h_{71}g_{52} + h_{61}g_{62} \\
 h_{112} &= h_{111}g_{02} + h_{101}g_{12} + h_{91}g_{22} + h_{81}g_{32} + h_{71}g_{42} + h_{61}g_{52} + h_{51}g_{62} \\
 h_{102} &= h_{101}g_{02} + h_{91}g_{12} + h_{81}g_{22} + h_{71}g_{32} + h_{61}g_{42} + h_{51}g_{52} + h_{41}g_{62} \\
 h_{92} &= h_{91}g_{02} + h_{81}g_{12} + h_{71}g_{22} + h_{61}g_{32} + h_{51}g_{42} + h_{41}g_{52} + h_{31}g_{62} \\
 h_{82} &= h_{81}g_{02} + h_{71}g_{12} + h_{61}g_{22} + h_{51}g_{32} + h_{41}g_{42} + h_{31}g_{52} + h_{21}g_{62} \\
 h_{72} &= h_{71}g_{02} + h_{61}g_{12} + h_{51}g_{22} + h_{41}g_{32} + h_{31}g_{42} + h_{21}g_{52} \\
 h_{62} &= h_{61}g_{02} + h_{51}g_{12} + h_{41}g_{22} + h_{31}g_{32} + h_{21}g_{42} \\
 h_{52} &= h_{51}g_{02} + h_{41}g_{12} + h_{31}g_{22} + h_{21}g_{32} \\
 h_{42} &= h_{41}g_{02} + h_{31}g_{12} + h_{21}g_{22} \\
 h_{32} &= h_{31}g_{02} + h_{21}g_{12} \\
 h_{22} &= h_{21}g_{02}
 \end{aligned}$$

(63)

$$\begin{aligned}
 h_{213} &= f_{83}d_{133} \\
 h_{203} &= f_{83}d_{123} + f_{73}d_{133} \\
 h_{193} &= f_{83}d_{113} + f_{73}d_{123} + f_{63}d_{133} \\
 h_{183} &= f_{83}d_{103} + f_{73}d_{113} + f_{63}d_{123} + f_{53}d_{133} \\
 h_{173} &= f_{83}d_{93} + f_{73}d_{103} + f_{63}d_{113} + f_{53}d_{123} + f_{43}d_{133} \\
 h_{163} &= f_{83}d_{83} + f_{73}d_{93} + f_{63}d_{103} + f_{53}d_{113} + f_{43}d_{123} + f_{33}d_{133} \\
 h_{153} &= f_{83}d_{73} + f_{73}d_{83} + f_{63}d_{93} + f_{53}d_{103} + f_{43}d_{113} + f_{33}d_{123} + f_{23}d_{133} \\
 h_{143} &= f_{83}d_{63} + f_{73}d_{73} + f_{63}d_{83} + f_{53}d_{93} + f_{43}d_{103} + f_{33}d_{113} + f_{23}d_{123} + f_{13}d_{133} \\
 h_{133} &= f_{83}d_{53} + f_{73}d_{63} + f_{63}d_{73} + f_{53}d_{83} + f_{43}d_{93} + f_{33}d_{103} + f_{23}d_{113} + f_{13}d_{123} \\
 h_{123} &= f_{83}d_{43} + f_{73}d_{53} + f_{63}d_{63} + f_{53}d_{73} + f_{43}d_{83} + f_{33}d_{93} + f_{23}d_{103} + f_{13}d_{113} \\
 h_{113} &= f_{83}d_{33} + f_{73}d_{43} + f_{63}d_{53} + f_{53}d_{63} + f_{43}d_{73} + f_{33}d_{83} + f_{23}d_{93} + f_{13}d_{103} \\
 h_{103} &= f_{83}d_{23} + f_{73}d_{33} + f_{63}d_{43} + f_{53}d_{53} + f_{43}d_{63} + f_{33}d_{73} + f_{23}d_{83} + f_{13}d_{93} + (64) \\
 h_{93} &= f_{83}d_{13} + f_{73}d_{23} + f_{63}d_{33} + f_{53}d_{43} + f_{43}d_{53} + f_{33}d_{63} + f_{23}d_{73} + f_{13}d_{83} + j \\
 h_{83} &= f_{73}d_{13} + f_{63}d_{23} + f_{53}d_{33} + f_{43}d_{43} + f_{33}d_{53} + f_{23}d_{63} + f_{13}d_{73} + f_{03}d_{83} \\
 h_{73} &= f_{63}d_{13} + f_{53}d_{23} + f_{43}d_{33} + f_{33}d_{43} + f_{23}d_{53} + f_{13}d_{63} + f_{03}d_{73} \\
 h_{63} &= f_{53}d_{13} + f_{43}d_{23} + f_{33}d_{33} + f_{23}d_{43} + f_{13}d_{53} + f_{03}d_{63} \\
 h_{53} &= f_{43}d_{13} + f_{33}d_{23} + f_{23}d_{33} + f_{13}d_{43} + f_{03}d_{53} \\
 h_{43} &= f_{33}d_{13} + f_{23}d_{23} + f_{13}d_{33} + f_{03}d_{43} \\
 h_{33} &= f_{23}d_{13} + f_{13}d_{23} + f_{03}d_{33} \\
 h_{23} &= f_{13}d_{13} + f_{03}d_{23} \\
 h_{13} &= f_{03}d_{13}
 \end{aligned}$$

$$\begin{aligned}
 h_{264} &= g_{51}h_{213} \\
 h_{254} &= g_{51}h_{203} + g_{41}h_{213} \\
 h_{244} &= g_{51}h_{193} + g_{41}h_{203} + g_{31}h_{213} \\
 h_{234} &= g_{51}h_{183} + g_{41}h_{193} + g_{31}h_{203} + g_{21}h_{213} \\
 h_{224} &= g_{51}h_{173} + g_{41}h_{183} + g_{31}h_{193} + g_{21}h_{203} \\
 h_{214} &= g_{51}h_{163} + g_{41}h_{173} + g_{31}h_{183} + g_{21}h_{193} \\
 h_{204} &= g_{51}h_{153} + g_{41}h_{163} + g_{31}h_{173} + g_{21}h_{183} \\
 h_{194} &= g_{51}h_{143} + g_{41}h_{153} + g_{31}h_{163} + g_{21}h_{173} \\
 h_{184} &= g_{51}h_{133} + g_{41}h_{143} + g_{31}h_{153} + g_{21}h_{163} \\
 h_{174} &= g_{51}h_{123} + g_{41}h_{133} + g_{31}h_{143} + g_{21}h_{153} \\
 h_{164} &= g_{51}h_{113} + g_{41}h_{123} + g_{31}h_{133} + g_{21}h_{143} \\
 h_{154} &= g_{51}h_{103} + g_{41}h_{113} + g_{31}h_{123} + g_{21}h_{133} \\
 h_{144} &= g_{51}h_{93} + g_{41}h_{103} + g_{31}h_{113} + g_{21}h_{123} \\
 h_{134} &= g_{51}h_{83} + g_{41}h_{93} + g_{31}h_{103} + g_{21}h_{113} \\
 h_{124} &= g_{51}h_{73} + g_{41}h_{83} + g_{31}h_{93} + g_{21}h_{103} \\
 h_{114} &= g_{51}h_{63} + g_{41}h_{73} + g_{31}h_{83} + g_{21}h_{93} \\
 h_{104} &= g_{51}h_{53} + g_{41}h_{63} + g_{31}h_{73} + g_{21}h_{83} \\
 h_{94} &= g_{51}h_{43} + g_{41}h_{53} + g_{31}h_{63} + g_{21}h_{73} \\
 h_{84} &= g_{51}h_{33} + g_{41}h_{43} + g_{31}h_{53} + g_{21}h_{63} \\
 h_{74} &= g_{51}h_{23} + g_{41}h_{33} + g_{31}h_{43} + g_{21}h_{53} \\
 h_{64} &= g_{51}h_{13} + g_{41}h_{23} + g_{31}h_{33} + g_{21}h_{43} \\
 h_{54} &= g_{41}h_{13} + g_{31}h_{23} + g_{21}h_{33} \\
 h_{44} &= g_{31}h_{13} + g_{21}h_{23} \\
 h_{34} &= g_{21}h_{13}
 \end{aligned}$$

(65)



$$\begin{aligned}
h_{215} &= f_{86}d_{132} \\
h_{205} &= f_{86}d_{122} + f_{76}d_{132} \\
h_{195} &= f_{86}d_{112} + f_{76}d_{122} + f_{66}d_{132} \\
h_{185} &= f_{86}d_{102} + f_{76}d_{112} + f_{66}d_{122} + f_{56}d_{132} \\
h_{175} &= f_{86}d_{92} + f_{76}d_{102} + f_{66}d_{112} + f_{56}d_{122} + f_{46}d_{132} \\
h_{165} &= f_{86}d_{82} + f_{76}d_{92} + f_{66}d_{102} + f_{56}d_{112} + f_{46}d_{122} + f_{36}d_{132} \\
h_{155} &= f_{86}d_{72} + f_{76}d_{82} + f_{66}d_{92} + f_{56}d_{102} + f_{46}d_{112} + f_{36}d_{122} + f_{26}d_{132} \\
h_{145} &= f_{86}d_{62} + f_{76}d_{72} + f_{66}d_{82} + f_{56}d_{92} + f_{46}d_{102} + f_{36}d_{112} + f_{26}d_{122} + f_{16}d_{132} \\
h_{135} &= f_{86}d_{52} + f_{76}d_{62} + f_{66}d_{72} + f_{56}d_{82} + f_{46}d_{92} + f_{36}d_{102} + f_{26}d_{112} + f_{16}d_{122} + f_{06}d_{132} \\
h_{125} &= f_{86}d_{42} + f_{76}d_{52} + f_{66}d_{62} + f_{56}d_{72} + f_{46}d_{82} + f_{36}d_{92} + f_{26}d_{102} + f_{16}d_{112} + f_{06}d_{122} \\
h_{115} &= f_{86}d_{32} + f_{76}d_{42} + f_{66}d_{52} + f_{56}d_{62} + f_{46}d_{72} + f_{36}d_{82} + f_{26}d_{92} + f_{16}d_{102} + f_{06}d_{112} \\
h_{105} &= f_{86}d_{22} + f_{76}d_{32} + f_{66}d_{42} + f_{56}d_{52} + f_{46}d_{62} + f_{36}d_{72} + f_{26}d_{82} + f_{16}d_{92} + f_{06}d_{102} \\
h_{95} &= f_{76}d_{22} + f_{66}d_{32} + f_{56}d_{42} + f_{46}d_{52} + f_{36}d_{62} + f_{26}d_{72} + f_{16}d_{82} + f_{06}d_{92} \\
h_{85} &= f_{66}d_{22} + f_{56}d_{32} + f_{46}d_{42} + f_{36}d_{52} + f_{26}d_{62} + f_{16}d_{72} + f_{06}d_{82} \\
h_{75} &= f_{56}d_{22} + f_{46}d_{32} + f_{36}d_{42} + f_{26}d_{52} + f_{16}d_{62} + f_{06}d_{72} \\
h_{65} &= f_{46}d_{22} + f_{36}d_{32} + f_{26}d_{42} + f_{16}d_{52} + f_{06}d_{62} \\
h_{55} &= f_{36}d_{22} + f_{26}d_{32} + f_{16}d_{42} + f_{06}d_{52} \\
h_{45} &= f_{26}d_{22} + f_{16}d_{32} + f_{06}d_{42} \\
h_{35} &= f_{16}d_{22} + f_{06}d_{32} \\
h_{25} &= f_{06}d_{22}
\end{aligned} \tag{66}$$

$$\begin{aligned}
h_{276} &= R_{S2}h_{215}g_{62} \\
h_{266} &= R_{S2}h_{215}g_{52} + R_{S2}h_{205}g_{62} \\
h_{256} &= R_{S2}h_{215}g_{42} + R_{S2}h_{205}g_{52} + R_{S2}h_{195}g_{62} \\
h_{246} &= R_{S2}h_{215}g_{32} + R_{S2}h_{205}g_{42} + R_{S2}h_{195}g_{52} + R_{S2}h_{185}g_{62} \\
h_{236} &= R_{S2}h_{215}g_{22} + R_{S2}h_{205}g_{32} + R_{S2}h_{195}g_{42} + R_{S2}h_{185}g_{52} + R_{S2}h_{175}g_{62} \\
h_{226} &= R_{S2}h_{215}g_{12} + R_{S2}h_{205}g_{22} + R_{S2}h_{195}g_{32} + R_{S2}h_{185}g_{42} + R_{S2}h_{175}g_{52} + R_{S2}h_{165}g_{62} \\
h_{216} &= R_{S2}h_{215}g_{02} + R_{S2}h_{205}g_{12} + R_{S2}h_{195}g_{22} + R_{S2}h_{185}g_{32} + R_{S2}h_{175}g_{42} + R_{S2}h_{165}g_{52} + R_{S2}h_{155}g_{62} \\
h_{206} &= R_{S2}h_{205}g_{02} + R_{S2}h_{195}g_{12} + R_{S2}h_{185}g_{22} + R_{S2}h_{175}g_{32} + R_{S2}h_{165}g_{42} + R_{S2}h_{155}g_{52} + R_{S2}h_{145}g_{62} \\
h_{196} &= R_{S2}h_{195}g_{02} + R_{S2}h_{185}g_{12} + R_{S2}h_{175}g_{22} + R_{S2}h_{165}g_{32} + R_{S2}h_{155}g_{42} + R_{S2}h_{145}g_{52} + R_{S2}h_{135}g_{62} \\
h_{186} &= R_{S2}h_{185}g_{02} + R_{S2}h_{175}g_{12} + R_{S2}h_{165}g_{22} + R_{S2}h_{155}g_{32} + R_{S2}h_{145}g_{42} + R_{S2}h_{135}g_{52} + R_{S2}h_{125}g_{62} \\
h_{176} &= R_{S2}h_{175}g_{02} + R_{S2}h_{165}g_{12} + R_{S2}h_{155}g_{22} + R_{S2}h_{145}g_{32} + R_{S2}h_{135}g_{42} + R_{S2}h_{125}g_{52} + R_{S2}h_{115}g_{62} \\
h_{166} &= R_{S2}h_{165}g_{02} + R_{S2}h_{155}g_{12} + R_{S2}h_{145}g_{22} + R_{S2}h_{135}g_{32} + R_{S2}h_{125}g_{42} + R_{S2}h_{115}g_{52} + R_{S2}h_{105}g_{62} \\
h_{156} &= R_{S2}h_{155}g_{02} + R_{S2}h_{145}g_{12} + R_{S2}h_{135}g_{22} + R_{S2}h_{125}g_{32} + R_{S2}h_{115}g_{42} + R_{S2}h_{105}g_{52} + R_{S2}h_{95}g_{62} \\
h_{146} &= R_{S2}h_{145}g_{02} + R_{S2}h_{135}g_{12} + R_{S2}h_{125}g_{22} + R_{S2}h_{115}g_{32} + R_{S2}h_{105}g_{42} + R_{S2}h_{95}g_{52} + R_{S2}h_{85}g_{62} \\
h_{136} &= R_{S2}h_{135}g_{02} + R_{S2}h_{125}g_{12} + R_{S2}h_{115}g_{22} + R_{S2}h_{105}g_{32} + R_{S2}h_{95}g_{42} + R_{S2}h_{85}g_{52} + R_{S2}h_{75}g_{62} \\
h_{126} &= R_{S2}h_{125}g_{02} + R_{S2}h_{115}g_{12} + R_{S2}h_{105}g_{22} + R_{S2}h_{95}g_{32} + R_{S2}h_{85}g_{42} + R_{S2}h_{75}g_{52} + R_{S2}h_{65}g_{62} \\
h_{116} &= R_{S2}h_{115}g_{02} + R_{S2}h_{105}g_{12} + R_{S2}h_{95}g_{22} + R_{S2}h_{85}g_{32} + R_{S2}h_{75}g_{42} + R_{S2}h_{65}g_{52} + R_{S2}h_{55}g_{62} \\
h_{106} &= R_{S2}h_{105}g_{02} + R_{S2}h_{95}g_{12} + R_{S2}h_{85}g_{22} + R_{S2}h_{75}g_{32} + R_{S2}h_{65}g_{42} + R_{S2}h_{55}g_{52} + R_{S2}h_{45}g_{62} \\
h_{96} &= R_{S2}h_{95}g_{02} + R_{S2}h_{85}g_{12} + R_{S2}h_{75}g_{22} + R_{S2}h_{65}g_{32} + R_{S2}h_{55}g_{42} + R_{S2}h_{45}g_{52} + R_{S2}h_{35}g_{62} \\
h_{86} &= R_{S2}h_{85}g_{02} + R_{S2}h_{75}g_{12} + R_{S2}h_{65}g_{22} + R_{S2}h_{55}g_{32} + R_{S2}h_{45}g_{42} + R_{S2}h_{35}g_{52} + R_{S2}h_{25}g_{62} \\
h_{76} &= R_{S2}h_{75}g_{02} + R_{S2}h_{65}g_{12} + R_{S2}h_{55}g_{22} + R_{S2}h_{45}g_{32} + R_{S2}h_{35}g_{42} + R_{S2}h_{25}g_{52} \\
h_{66} &= R_{S2}h_{65}g_{02} + R_{S2}h_{55}g_{12} + R_{S2}h_{45}g_{22} + R_{S2}h_{35}g_{32} + R_{S2}h_{25}g_{42} \\
h_{56} &= R_{S2}h_{55}g_{02} + R_{S2}h_{45}g_{12} + R_{S2}h_{35}g_{22} + R_{S2}h_{25}g_{32} \\
h_{46} &= R_{S2}h_{45}g_{02} + R_{S2}h_{35}g_{12} + R_{S2}h_{25}g_{22} \\
h_{36} &= R_{S2}h_{35}g_{02} + R_{S2}h_{25}g_{12} \\
h_{26} &= R_{S2}h_{25}g_{02}
\end{aligned} \tag{67}$$

$$\begin{aligned}
 h_{277} &= h_{276} \cdot h_{267} = h_{266} - h_{264} \\
 h_{257} &= h_{256} - h_{254}, h_{247} = h_{246} - h_{244} \\
 h_{237} &= h_{236} - h_{234}, h_{227} = h_{226} - h_{224} \\
 h_{217} &= h_{216} - h_{214}, h_{207} = h_{206} - h_{204} \\
 h_{197} &= h_{196} - h_{194}, h_{187} = h_{186} - h_{184} \\
 h_{177} &= h_{176} - h_{174}, h_{167} = h_{166} - h_{164} \\
 h_{157} &= h_{156} - h_{154}, h_{147} = h_{146} - h_{144} \\
 h_{137} &= h_{136} - h_{134}, h_{127} = h_{126} - h_{124} \\
 h_{117} &= h_{116} - h_{114}, h_{107} = h_{106} - h_{104} \\
 h_{97} &= h_{96} - h_{94}, h_{87} = h_{86} - h_{84} \\
 h_{77} &= h_{76} - h_{74}, h_{67} = h_{66} - h_{64} \\
 h_{57} &= h_{56} - h_{54}, h_{47} = h_{46} - h_{44} \\
 h_{37} &= h_{36} - h_{34}, h_{27} = h_{26}
 \end{aligned}
 \tag{68}$$

$$Z_{12} = \frac{50R_{S2} \begin{pmatrix} s^{27}h_{272} + s^{26}h_{262} + s^{25}h_{252} + s^{24}h_{242} + s^{23}h_{232} + s^{22}h_{222} \\ + s^{21}h_{212} + s^{20}h_{202} + s^{19}h_{192} + s^{18}h_{182} + s^{17}h_{172} + s^{16}h_{162} \\ + s^{15}h_{152} + s^{14}h_{142} + s^{13}h_{132} + s^{12}h_{122} + s^{11}h_{112} + s^{10}h_{102} \\ + s^9h_{92} + s^8h_{82} + s^7h_{72} + s^6h_{62} + s^5h_{52} + s^4h_{42} \\ + s^3h_{32} + s^2h_{22} \end{pmatrix}}{\begin{pmatrix} s^{27}h_{277} + s^{26}h_{267} + s^{25}h_{257} + s^{24}h_{247} + s^{23}h_{237} + s^{22}h_{227} \\ + s^{21}h_{217} + s^{20}h_{207} + s^{19}h_{197} + s^{18}h_{187} + s^{17}h_{177} + s^{16}h_{167} \\ + s^{15}h_{157} + s^{14}h_{147} + s^{13}h_{137} + s^{12}h_{127} + s^{11}h_{117} + s^{10}h_{107} \\ + s^9h_{97} + s^8h_{87} + s^7h_{77} + s^6h_{67} + s^5h_{57} + s^4h_{47} \\ + s^3h_{37} + s^2h_{27} \end{pmatrix}}
 \tag{69}$$

This is the last equation of impedance parameter in polynomial.

It can be seen from Fig. 2 that graph of  $Z_{11}$  is the strangest graph because it should be equal with  $Z_{22}$  but it is not equal. It can also be seen that graph of  $Z_{21}$  is not equal with graph of  $Z_{12}$ .

### III. CONCLUSION

It can be conclude that scattering parameter graph can be plotted from impedance parameters from reference textbook in microwave engineering but everyone might wonder that there are something wrong in derivation or not because cross couple oscillator is symmetrical network but the graph result is not symmetrical. Author apologizes for something wrong of these graph and formulas but try very hard for this paper.

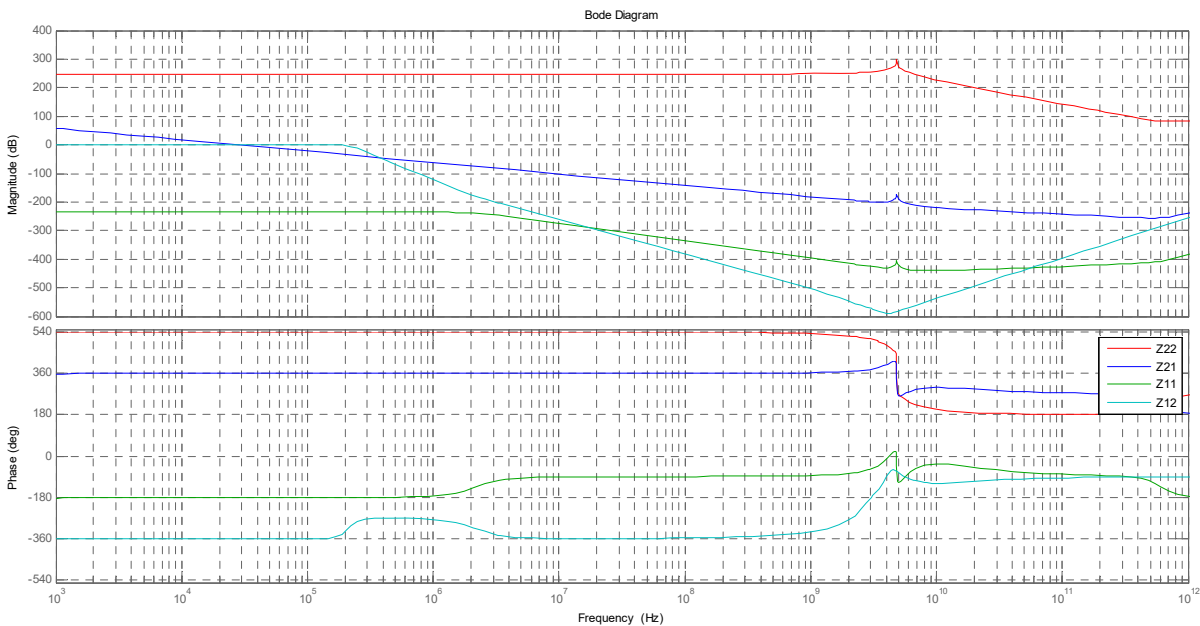

Fig. 2 Magnitude and Phase response of Impedance parameter

### REFERENCES

- [1] H. J. Carlin, "The Scattering Matrix in Network Theory", IRE Transactions on Circuit Theory", June 1956, pp. 88-97.
- [2] K. Kurokawa, "Power Waves and the Scattering Matrix", IEEE Transactions on Microwave Theory and Technique, March 1965, pp. 194-202.
- [3] D. M. Pozar, "Microwave Engineering", 2<sup>nd</sup> edition, Wiley, copyright 1998
- [4] B. Razavi, "RF Microelectronics", 2<sup>nd</sup> edition, Prentice-Hall, copyright 2012.
- [5] D. O. Pederson, K. Mayaram, "Analog Integrated Circuits for Communication", Principles, Simulation and Design, 2<sup>nd</sup> edition, Springer Verlag, copyright 2008.

**Kittipong Tripetch** (S'99-AM'01-M'02-GSM'14) was born since 15 September 1972 in Bangkok, Thailand. He received his master degree in electrical engineering with a major in Microelectronic engineering from Mahanakorn University of Technology since 2002. He received his bachelor degree in electrical engineering with a major in Telecommunication engineering from Mahanakorn University of Technology since 1996. After graduation, he has been employed by division of electronic and telecommunication engineering, Faculty of Engineering and Architecture, Rajamangala University of Technology Suvarnabhumi, Nonthaburi Campus since August 2004 until now. He published conference paper about 9 papers in IEEE Explore since 2007.

Since April 2014, he have been studying for Ph.D degree at Graduate School of Science and Technology, Department of Electronic and Electrical engineering, Keio University, Yokohama, Japan.