

Failure Analysis of Pipe System at a Hydroelectric Power Plant

Ali Gökseml, Barlas Eryürek

Abstract—In this study, failure analysis of pipe system at a micro hydroelectric power plant is investigated. Failure occurred at the pipe system in the powerhouse during shut down operation of the water flow by a valve. This locking had caused a sudden shock wave, also called “Water-hammer effect”, resulting in noise and inside pressure increase. After visual investigation of the effect of the shock wave on the system, a circumference crack was observed at the pipe flange weld region. To establish the reason for crack formation, calculations of pressure and stress values at pipe, flange and welding seams were carried out and concluded that safety factor was high (2.2), indicating that no faulty design existed. By further analysis, pipe system and hydroelectric power plant was examined. After observations it is determined that the plant did not include a ventilation nozzle (air trap), that prevents the system of sudden pressure increase inside the pipes which is caused by water-hammer effect. Analyses were carried out to identify the influence of water-hammer effect on inside pressure increase and it was concluded that, according Jowkowsky’s equation, shut down time is effective on inside pressure increase. The valve closing time was uncertain but by a shut down time of even one minute, inside pressure would increase by 7.6 bar (working pressure was 34.6 bar). Detailed investigations were also carried out on the assembly of the pipe-flange system by considering technical drawings. It was concluded that the pipe-flange system was not installed according to the instructions. Two of five weld seams were not applied and one weld was carried out faulty. This incorrect and inadequate weld seams resulted in; insufficient connection of the pipe to the flange constituting a strong notch effect at weld seam regions, increase in stress values and the decrease of strength and safety factor.

Keywords— Failure analysis, hydroelectric plant, water-hammer, crack, welding seam.

I. INTRODUCTION

POWER generation from water is a combination of head and flow. Both must exist to produce electricity. The investigated hydroelectric power plant in our case is a “Micro Hydro Power Plant”, which produces up to 100 kW electricity. In the investigated system, the plant is in “run-of-river” type. In run-of-river type systems, water is diverted from the natural stream, river, or sometimes a waterfall and no dam or water storage is constructed [1]. Further water is channeled in to a valley through a pipeline, also called penstock, to the powerhouse building where water is dropped [2]. The vertical drop generates pressure at the bottom end of the pipeline. The pressurized water moving out from the end of the pipe strikes the turbine which leads to a force increase that rotates the

turbine [2], [3]. The turbine turns the generator which is connected to electrical loads whereby electrical power is produced. In the investigated plant, two power systems are placed in succession. Waterfall height is 295.3 m, tunnel length 6419 m, penstock length 390 m, pipe diameter 2 m and flow rate is 11 m³/s (Fig. 1). Failure had occurred at the second powerhouse pipe system.

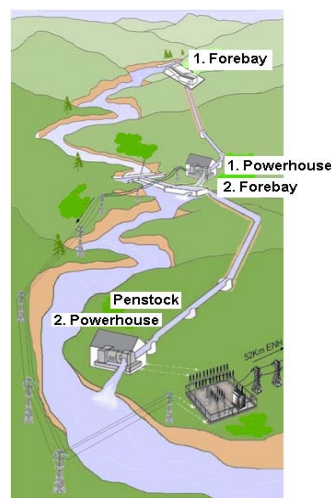

Fig. 1 Layout of the hydraulic power plant

The turbine consists of two pelton wheels. The flow inside the pipe is controlled by a butterfly valve. The opening-shutting down velocity of the valve is very important. By a rapid shut down of the check valve at the downstream, the mass of water before the closure is still moving and building up high pressure. This pressure increase results in a shock wave, which is also called “Water-hammer” [4]-[6]. It is experienced as a loud banging, resembling a hammering noise. Water hammer loads must be kept within the described limits. They can damage operation of hydraulic system and system’s components, like turbines, valves and some other attached equipment of the system [7]. Eventually, water-hammer may cause costly damage to facilities and equipment, serious injuries and loss of human lives which has been seen in history by huge hydropower accidents [8]. Surge tanks, air chambers, pressure relief valves, safety membranes, fly wheels are some of the control devices used in small hydropower plants for safety [9], [10]. Air traps or stand pipes, which is open at the top are added as a damper. As the water rises up the shaft, its kinetic energy is converted into potential energy, which decelerates the water in the tunnel to absorb the potentially

A. G. and B. E. are with the Mechanical Engineering Faculty, Istanbul Technical University, 34437, Istanbul, Turkey (phone: 90-212-2931300 (2480), 90-212-2931300 (2428); fax: 90-212-2450795; e-mail: goksenli@itu.edu.tr, eryurekb@itu.edu.tr).

damaging forces [11]. In our case, for maintenance the butterfly valve was shut down resulting in a hammer like noise increase which had lasted for 10 minutes. After the waterfall incident, a circumference crack was detected at the flange-pipe welding zone. Investigations were carried out to determine the procedure after the crack formation.

II. VISUAL INSPECTION

As can be seen in Fig. 2, circumference crack had been constituted at the flange-pipe welding zone.

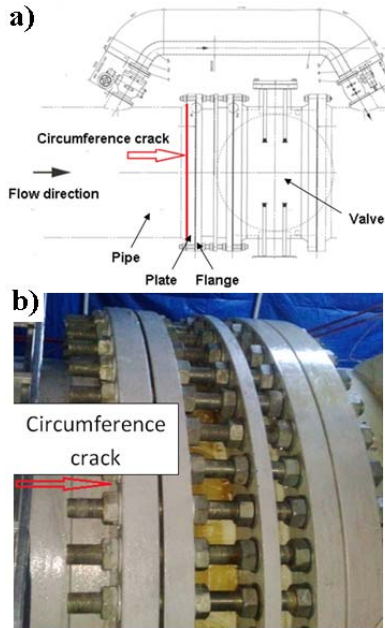

Fig. 2 General view of the flange-plate-pipe system and circumference crack

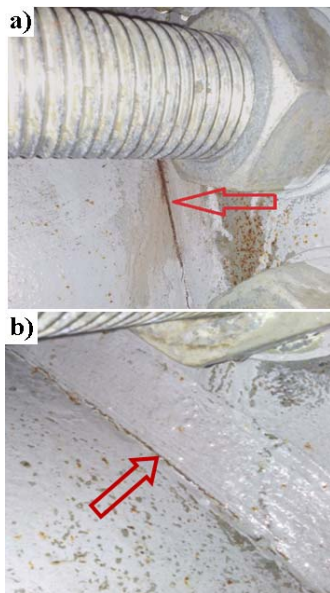

Fig. 3 Crack formation in pipe-plate welding zones

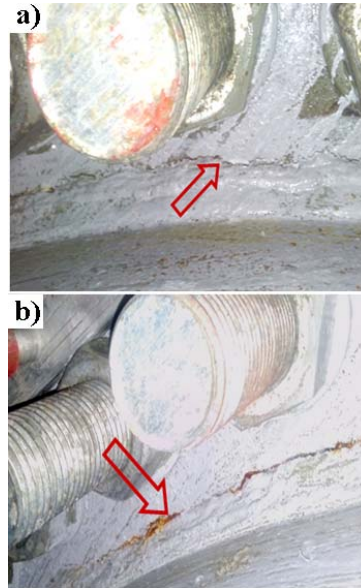

Fig. 4 Crack formation in pipe-flange welding zones

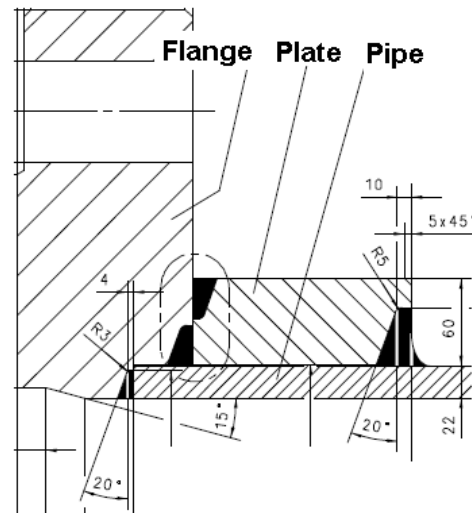

Fig. 5 Technical drawing of the pipe-plate-flange system

After detailed investigation it is concluded that crack had been propagated in pipe-plate welding zones (Fig. 3) and in pipe-flange plate welding zones (Fig. 4).



III. STRESS ANALYSIS

The design of the flange-pipe region can be seen in Fig. 5. To strengthen the pipe, a plate is welded at four regions to the pipe and flange. Flange material is steel St 52-3.

To determine stresses occurring at the weld zones during water stream, calculations were carried out. Pipe inside diameter is 1984 mm and wall thickness is 84 mm. Water fall height is 295.3 m, penstock length 390 m and flow rate is 11 m³/s. According to the given values, pressure inside the pipe is calculated as 34.6 bars. Stress values at the weld zone is

calculated by considering sections A-A and C-C, which can be seen in Table I.

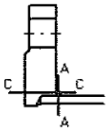
TABLE I
STRESS CALCULATIONS AT THE WELDED REGION

	Section	Stress [MPa]	Yield strength [MPa]	Safety factor
	A-A	138.2	315	2.2
	C-C	48.0	315	6.5

By static water flow (34.6 bar), stresses acting in welded sections are lower than yield strength and safety factor is high (min. 2.2 in section A-A). To determine the water-hammer effect, Jowkowsky's equation (1) is considered [12]:

$$\Delta p = \frac{0.2 \cdot c \cdot L}{T_C \cdot g} \quad (1)$$

Δp is pressure rise due to water-hammer effect [bar], a is speed of sound of water in the penstock [m/s], c is maximum flow velocity [m/s], g gravity [m/s^2], L length of the pipe system [m] and T_C is time to close the main valve or guide vanes [s]. Length of the pipe system is 6419 m, maximum velocity is 3.5 m/s and speed of sound of water in pipe is 1.481 m/s (@ 20 °C). From (1) can be seen that pressure rise due to water-hammer (Δp) depends on time to close the main valve or guide vanes (T_C). According to the given values, relation between Δp and T_C can be seen in Fig. 6.

As can be seen in Fig. 6, even a valve closing time of one minute will cause a pressure increase of 7.6 bar. The valve closing time at the accident day is not clear, but it is certain that the shut down time of the valve was not considered by the operator, which had resulted in a water-hammer effect.

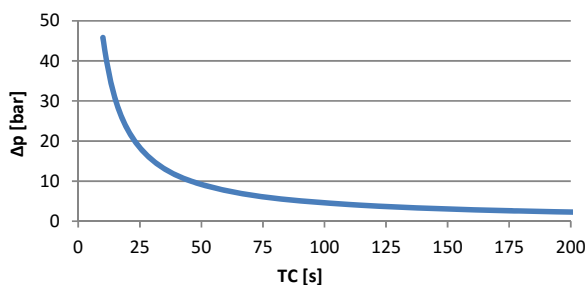

Fig. 6 Relation between pressure rise due to water hammer (Δp) and time to close the main valve (T_C)

IV. FAILURE ANALYSIS

From Table I can be seen, that safety factor in the critical A-A section is 2.2, which demonstrates that inside water pressure during operation could not be the reason for the crack formation. Therefore detailed analysis was carried out on the welded flange, plate and pipe region. Considering technical drawing of the assembly of the plate, as can be seen in Fig. 7, the plate is welded to the pipe and flange by using four weld seams.

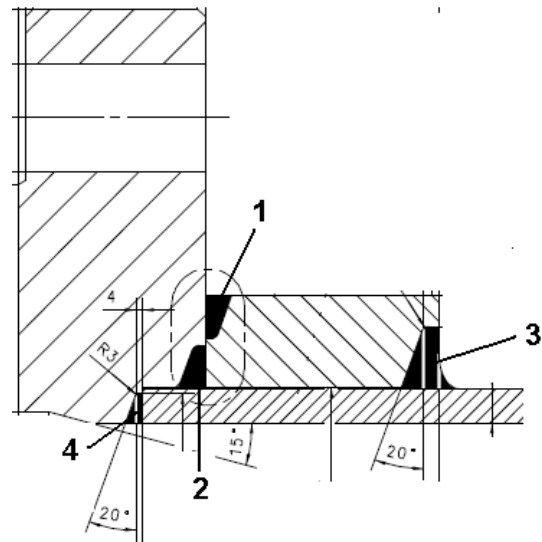

Fig. 7 Assembly drawing of the plate-flange-pipe system

Weld seams 1 and 2 are applied between plate and flange, weld 3 between plate and pipe and weld 4 between pipe and flange as can be seen in Fig. 7. For further detailed weld analysis it is investigated if these mentioned four weld seams are applied correct as can be seen in Fig. 7. During observation an additional weld seam, which was not mentioned in assembly drawing in Fig. 7 was detected, as can be seen in Fig. 8.

To analyze weld seam 1 and 2, weld seam 5 was grinded. After grinding it is detected that weld groove for weld 1 and 2 was constituted, but no welding process for weld 1 and 2 was applied, as can be seen Fig. 9. Therefore, a gap under weld 5 existed.

After weld seam analysis it is concluded that assembly of the plate-flange-pipe system was not applied correctly. Weld seams 1 and 2 were not applied; only weld grooves of weld 1 and 2 were constituted. The unfilled grooves 1 and 2 acted as inside cracks resulting in a strong notch effect. Stresses raised at this region caused crack propagation to the weld seam 5. By further investigation it is detected that weld groove for weld 3 was prepared incorrect. Groove angle was 70° instead of 20°. This had resulted in an increase of weld thickness from 25 mm to 110 mm, as can be seen in Fig. 10. This has resulted in a decrease of safety of the pipe-plate system, due to the low strength and high brittleness of weld seam according to base material.

In consequence of the calculations, it was detected that safety factor is 2.2. But considering water-hammer effect, inside pressure was higher than calculated water pressure of 34.6 bar, which resulted in an increase in stress value and decrease in safety factor values in the flange-pipe region. Considering the incorrect welding seams, resulting in a further increase in stress values, will decrease further the safety factor to a critical value. Therefore reason for the crack formation was water-hammer effect and defective and deficient welding seams.

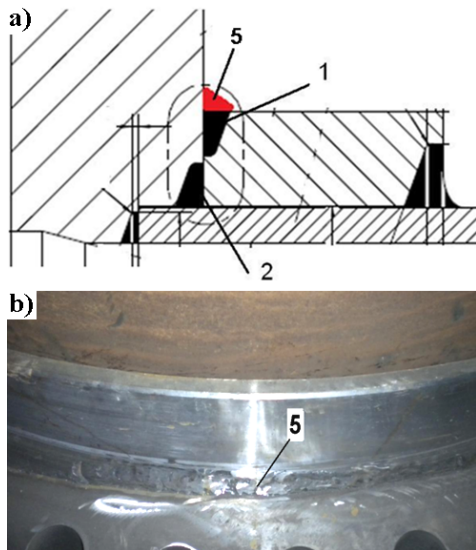

Fig. 8 Weld seam no.5 (b), which was not mentioned in assembly drawing as can be seen in Fig. 7

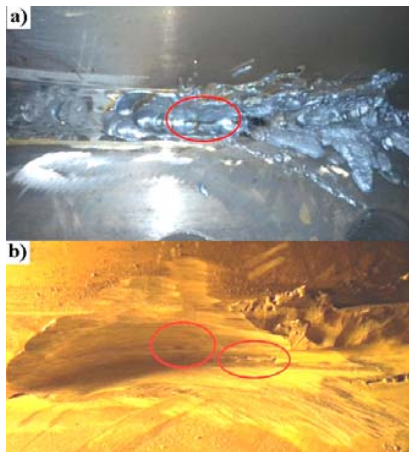

Fig. 9 Weld groove of weld seam 1 and no welding process

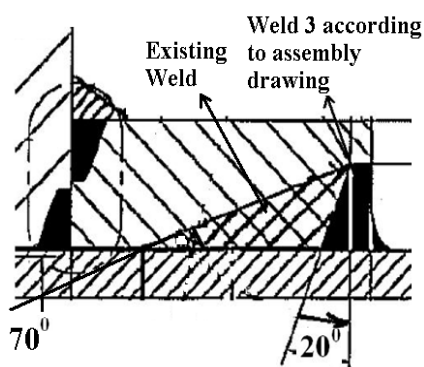

Fig. 10 Incorrect weld groove of weld seam 3

V. CONCLUSIONS

In this study, failure analysis of pipe system at a hydroelectric power plant is investigated. During shut down

operation of the pipe line system for maintenance of the pipes, a sudden shock wave had been comprised inside the pipe system. This shock wave, also named as water-hammer effect, resulted in a huge noise at the valve shut down region, concluding in a crack formation. At first, properties of the pipe system were examined, pressure and stress values at pipe, flange, flange, and welding seams were calculated, and assembly drawings of the pipe-flange system and the plant were investigated. After observations and analyzes it is concluded that sudden pressure increase, because of water-hammer effect, resulted in a crack formation at the pipe system. By further investigation it is detected that during assembly of flange to the pipe-flange system, weld seams were not applied correctly. Two welding seams were not performed and one welding seam was incorrect welded. This incorrect welding system had resulted in an inside crack formation and insufficient connection of the pipe to the flange.

REFERENCES

- [1] V. Vineesh V, and A. I. Selvakumar, "Design of Micro Hydel Power Plant," *International Journal of Engineering and Advanced Technology*, vol. 2, 2012, pp. 136-140.
- [2] B.A. Nasir, "Design of Micro - Hydro - Electric Power Station," *International Journal of Engineering and Advanced Technology*, vol. 2, 2013, pp. 39-47.
- [3] H. Sharma, and J. Singh, "Run off River Plant: Status and Prospects," *International Journal of Innovative Technology and Exploring Engineering*, 2278-3075, vol. 3, 2013, pp. 2278-3075.
- [4] M. Çalamak, and Z. Bozkus, "Protective Measures against Waterhammer in Run-of-River Hydropower Plants," *Digest*, vol.12, 2012, pp. 1623-1636.
- [5] T.W. Choon, L.K. Aik, L.E. Aik, and T. T. Hin, "Investigation of Water Hammer Effect through Pipeline System," *International Journal on Advance Science Engineering Information Technology*, vol. 7, 2012 pp. 48-53.
- [6] S. Dursun, and Z. Bozkus, "Numerical Investigation of Protection Measures Against Water Hammer in the Yesilvadi Hydropower Plant," *11th International Congress on Advances in Civil Engineering*, Istanbul 2014.
- [7] J. Wood, "Waterhammer Analysis—Essential and Easy „and Efficient" *Journal of Environmental Engineering*, vol. 8, 2005, pp. 1123-1131.
- [8] A. Leishear, Fluid Mechanics, *Water Hammer, Dynamic Stresses, and Piping Design*, ASME, New York, 2012.
- [9] A. Dudlik, S.B. Handajani, Schönfeld, S. Schlüter, H. Fahlenkamp, and H.M. Prasse, "Prevention of Water Hammer and Cavitation Hammer in Pipeline Systems," *Chemical Engineering & Technology*, vol. 09, 2002; pp. 888-890.
- [10] K. Paffel, "The number One Problem in a Steam System: Waterhammer," *Chemical Engineering*, vol. 4, 2008, pp. 1-4.
- [11] G. Gjetvaj, and M. Tadic, "The Effect of Water Hammer on Pressure Increase in Pipelines Protected by an Air Vessel," *Technical Gazette*, vol. 21, 2014, pp. 479-484.
- [12] S. Mohamed, M. Ghidaoui, Z. Duncan, and H. Axworthy, "A Review of Water Hammer Theory and Practice," *Applied Mechanics Reviews*, vol. 58, 2005, pp. 49-76.