

# The Transient Reactive Power Regulation Capability of SVC for Large Scale WECS Connected to Distribution Networks

Y. Ates, A. R. Boynuegri, M. Uzunoglu, A. Karakas

**Abstract**—The recent interest in alternative and renewable energy systems results in increased installed capacity ratio of such systems in total energy production of the world. Specifically, Wind Energy Conversion Systems (WECS) draw significant attention among possible alternative energy options, recently. On the contrary of the positive points of penetrating WECS in all over the world in terms of environment protection, energy independence of the countries, etc., there are significant problems to be solved for the grid connection of large scale WECS. The reactive power regulation, voltage variation suppression, etc. can be presented as major issues to be considered in this regard. Thus, this paper evaluates the application of a Static VAR Compensator (SVC) unit for the reactive power regulation and operation continuity of WECS during a fault condition. The system is modeled employing the IEEE 13 node test system. Thus, it is possible to evaluate the system performance with an overall grid simulation model close to real grid systems. The overall simulation model is developed in MATLAB/Simulink/SimPowerSystems® environments and the obtained results effectively match the target of the provided study.

**Keywords**—IEEE 13 bus distribution system, reactive power regulation, static VAR compensator, wind energy conversion system.

## I. INTRODUCTION

A recent topic of interest for the sustainable growth of the world converges on a common point: Supplying the increasing energy demand of the world with an environmental friendly and energy efficient generation chain. Several researchers from both academic and industrial world as well as policy-makers of both developed and developing countries have investigated and proposed many different solutions on the mentioned issue. The most favorable solution is presented as the investigation and widespread utilization of renewable and alternative energy sources [1]. Among different alternative sources of energy such as wind, solar, hydrogen, bio-fuels, etc., the wind energy conversion systems (WECS) can be considered as the most mature and prevalent technology with a significant ratio of WECS in total installed energy generation portfolio [2], [3]. However, this issue provides the necessity of a detailed analysis on the grid connection issue. The stochastic nature of WECS due to the irregularity of wind speed is the main reason of this requirement. There are many grid codes especially for the grid connection of WECS and several aspects such as voltage and frequency variation limits, reactive power content, etc. have

been taken into account [4], [5]. These issues are especially important during a fault condition that may occur close to WECS. The mentioned faults generally occur as short circuits as either balanced (three-phase) or unbalanced (phase to phase or single-phase). The WECS should overcome these kinds of abnormal conditions that are likely to face in real time applications with additional “Flexible AC Transmission Systems (FACTS)” such as Static VAR Compensator (SVC), Static Synchronous Compensator (STATCOM), etc. and relevant control strategies [6]. The grid connected WECS especially with squirrel-cage induction generator (SCIG) meets their reactive power requirements from the grid. If the WECS is connected to distribution network and a fault occurs at the distribution level, the reactive power requirements of WECS after fault conditions will be supplied from the grid impedance with higher values. In this condition, this issue provides transient peaks on grid voltage. Especially, due to the fact that the mentioned problems directly reflect to the end-users at the distribution level, the utilization of FACTS devices and their rapid control gain more importance [7].

Different studies have been conducted to provide solutions for a continuous operation of WECS during such fault conditions. Ramirez et al. [8] realized a study for enhancing the low voltage ride through (LVRT) capability of WECS utilizing STATCOM under single phase and three phase fault conditions for Spanish grid system. The voltage falling to 0.5 pu (from 400 V to 200 V) in unregulated condition without STATCOM is kept within the band of 380-400 V with the utilization of STATCOM in [8]. Petersa et al. [9] provide a study especially focusing on voltage regulation of a grid connected 900 kW WECS utilizing SVC. A ratio of 1% from 0.96 pu to 0.97 pu under fault conditions is obtained in the voltage of the grid connection point in [9]. Kyaw and Ramachandaramurthy [10] proposed a control methodology utilizing the standard fault response curve in order to regulate the voltage drop during a fault condition in a test model of Malaysian grid system. A fast response is obtained in [10] for overcoming the voltage drop during the first steps of the operation under fault condition, however totally suppressing the voltage drop to the nominal voltage value required a significantly longer time compared to the first fast response of the algorithm. Different power quality problems such as slow voltage variations, fast voltage variations (flickers), harmonics, voltage dips and sags, etc. were investigated in [11]-[15]. The voltage regulation during fault conditions by SVC was considered by [16] and [17] both in simulation and

Y. Ates is with the Yildiz Technical University, İstanbul, Turkey. (e-mail: yates@yildiz.edu.tr).

experimental environments.

The above-mentioned studies together with other studies of different authors can easily be found in the literature provided contributions to the uninterrupted grid connection of WECS in fault conditions. However, the performance evaluation of FACTS devices with a distribution network that can provide the possibility of evaluating the effects of fault condition to different areas of a distribution network is considered in this study. Related with this issue, the connection of WECS to transmission systems with high short circuit powers provides the necessity of extra investments such as extra transmission line installations, addition of new transformers, etc. Accordingly, the connection of WECS to distribution systems instead of transmission systems has recently drawn attention in order to promote the widespread utilization of WECS and other types of distributed generation (DG) systems. As the fault conditions generally occur at the distribution level and the recent installed WECS are generally connected to distribution network as mentioned, this study investigates the possible cases of distribution network connected WECS instead of transmission network connected WECS during fault conditions. In this regard, IEEE 13 node test system employed as a distribution network model is realized in MATLAB/SimPowerSystems environment firstly. In the next step, a WECS model which is suitable for system structure and sufficient for supplying the power demand is integrated within the test system. After the modeling of the DG based IEEE 13 node test system is completed, the next step as the main target of the study is dedicated to solving possible overvoltage and unregulated reactive power issues occurring during and after the fault conditions at regions close to the WECS. To totally overcome or minimize such drawbacks during and after the fault, a three phase reactive power controlled SVC is modeled and adapted to the test system and the performance of the employed SVC with relevant control strategy is evaluated from different points of view.

This paper is organized as follows. Section II describes the methodology including the explanations the test system, WECS and SVC units with relevant control strategy. The obtained results of the simulation are given in Section III. Finally, the overall study is discussed and conclusions are presented in Section IV.

## II. SYSTEM DESCRIPTION AND METHODOLOGY

In order to provide solutions for overvoltage and reactive power problems occurring after fault conditions, IEEE 13 node test system is modeled in simulation environment. By the integration of the WECS as a fundamental renewable energy unit with the overall test system, the possible effects of especially voltage and reactive power variations during fault conditions are analyzed. The modeled SVC is located close to the WECS and solutions are evaluated for the problems occurring after fault conditions at distribution network. The general system configuration is shown in Fig. 1 and the relevant sub-details of the evaluated structure are presented below:

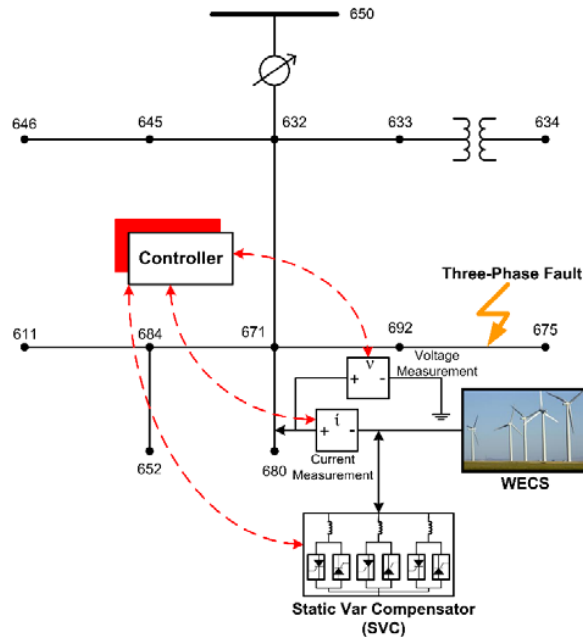

Fig. 1 General system configuration

TABLE I  
SPOT LOAD DATA FOR IEEE 13 NODE TEST FEEDERS

Node	Load Model	Ph-1 kW	Ph-1 kVA <sub>r</sub>	Ph-2 kW	Ph-2 kVA <sub>r</sub>	Ph-3 kW	Ph-3 kVA <sub>r</sub>
634	Y-PQ	160	110	120	90	120	90
645	Y-PQ	0	0	170	125	0	0
646	D-Z	0	0	230	132	0	0
652	Y-Z	128	86	0	0	0	0
671	D-PQ	385	220	385	220	385	220
675	Y-PQ	485	190	68	60	290	212
692	D-I	0	0	0	0	170	151
611	Y-I	0	0	0	0	170	80
TOTAL		1158	606	973	627	1135	753

### A. IEEE 13 Node Test System and Employed WECS Based DG Unit

The performance of the SVC unit for effective continuous operation of grid connected WECS is evaluated using IEEE 13 node test system as stated before. The IEEE 13 node test system shown in Fig. 1 includes single, double and three phase lines and loads, making it significantly suitable for evaluating the proposed methodology. The system lines 684-652 and 684-611 are single phase; lines 671-684, 632-645, 645-646 are two phase and the remaining lines are three phase. The system contains linear, nonlinear, and/or unbalanced loads. The load data of the mentioned system is summarized in Table I. Further complete network data and parameters can be found in [18].

The mentioned test system is modified with the adaptation of WECS based DG unit. The WECS design is realized with a pre-evaluation of power flows within the test system for the integration of the DG unit with the modelled test system. Considering closeness to the determined fault point, the grid connection is realized between buses 671 and 680. According

to Fig. 1, a 1.375 MW WECS composed of 5 wind turbines of 275 kW is connected to the 4.16 kV IEEE 13 node test feeder. WECS uses a SCIG and the wind speed during the fault is determined as 10 m/s. As the considered WECS provides the maximum output power at this wind speed level, this wind speed value is selected in this study.

**B. SVC Unit and Relevant Control System**

SVC is an adjustable shunt connected static VAR generator/load to exchange capacitive/inductive current in order to regulate desired power system variables. Main reasons for employing a SVC unit can be presented as dynamic voltage control, additional signal stabilizing, oscillation damping, supplementary control, etc. [19]. For WECS, SVC units can be employed for fast-acting reactive power compensation with the ability of separately controlling each phase to overcome imbalance conditions [17].

The SVC used in the study includes three main components as seen in Fig. 2: the reactor, the fixed capacitor and the power switch (FC-TCR). The injected steady state current by SVC is obtained as [20]

$$I = \begin{cases} \frac{U}{X_L} (\cos\alpha_{SVC} - \cos\omega t), & \alpha_{SVC} \leq \omega t < \alpha_{SVC} + \sigma \\ 0, & \alpha_{SVC} + \sigma \leq \omega t < \alpha_{SVC} + \pi \end{cases} \quad (1)$$

where U is the voltage at SVC connection point, that is the voltage to be controlled, XL is the total inductance, Xc is the capacitor, asvc is the firing delay angle, s is defined as the SVC conduction angle according to:

$$\sigma = 2(\pi - \alpha_{SVC}) \quad (2)$$

The variable susceptance, BsVC, of SVC could be expressed as:

$$B_{SVC} = \frac{2\pi - \alpha_{SVC} + \sin 2\alpha_{SVC}}{\pi X_L} \quad (3)$$

Reactive power regulation is accomplished by varying the firing angle of the SVC. The reactive power injected by the SVC is calculated by,

$$Q_{SVC} = \frac{U^2}{X_C} - U^2 B_{SVC} \quad (4)$$

It is to be noted that the L and C parameters of SVC are 1.38 mH and 15.9 μF, respectively. Besides, QL and QC operating limits of the SVC are 4000 kVAr inductive and 5000 kVAr capacitive totally for three phases.

With the integration of the WECS to the provided 13 bus test system, it is required to provide solutions to the voltage regulation and reactive power problems especially within the conditions of fault. The SVC unit employed close to the grid connection point of WECS is utilized for providing solutions to the mentioned problems. The control algorithm with the block diagram shown in Fig. 3 is developed in order to provide reactive power regulation and then applied to the SVC through the control unit.

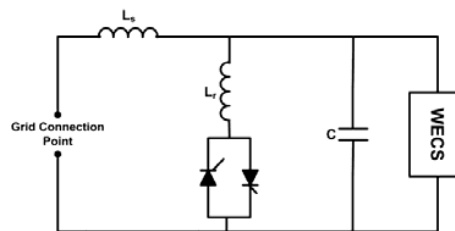

Fig. 2 (FC-TCR) SVC configurations

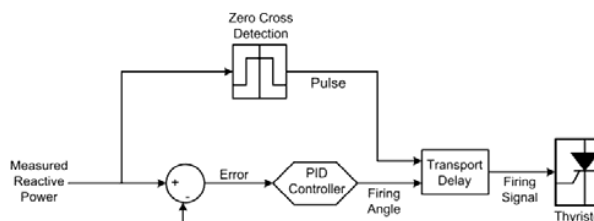

Fig. 3 Control algorithm for SVC unit

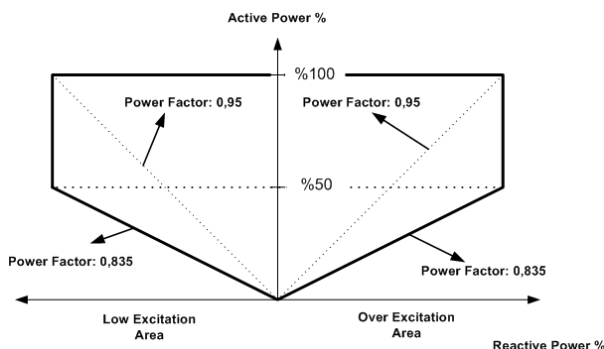

Fig. 4 The reactive power grid code for WECS

It is aimed with the controlled adaptation of SVC with the applied control algorithm to ensure the continuous power flow of WECS during undesired fault conditions. Besides, the grid code for reactive power given in Fig. 4 is also considered in the control methodology. Thus, the fault-ride through capability of WECS is promoted by the proposed structure. The first step of the mentioned control algorithm seen in Fig. 3 is the reactive power measurement from the grid connection point of WECS. The measured power value is compared with the reference power value determined as zero. If the measured power value is detected to be different from zero after comparison, this difference is evaluated as an error. This error value is supplied as an input to the PID algorithm and firing angles between 90o and 180o are generated to provide the error value to be zero. Thus, the aimed reactive power value is obtained as the conditions are improved with the generated signal after the firing angle. Accordingly, the reactive power requirement within the grid connection point is supplied by SVC due to the fact that the reactive power of WECS at the mentioned grid connection point is regulated as zero.

### III. TEST AND RESULTS

In this study realized within DG plant based IEEE 13 bus test system, a three phase short circuit fault is analysed at bus 675 that is close point to the WECS. In order to observe the conditions occurring during and after the fault, the fault period is determined as 0.5 seconds between 1.5-2 seconds. Accordingly, the test results obtained with the simulation model are presented in Figs. 5-9.

If the obtained voltage variation results are analysed, the steady state voltage at the beginning of the simulation is nearly 2.5% better regulated to nominal phase-neutral voltage of WECS compared to case without SVC. Besides, the voltage of WECS reaches to 6500 V peak without SVC during the fault as seen in Fig. 5. The mentioned peak voltage is 3500 V with the utilization of SVC. The SVC unit employed in the study considerably regulates and approximates the voltage value to the desired reference values even it is designed as reactive power controlled. Moreover, the employed SVC and the control algorithm regulate the voltage within  $\pm 15\%$  voltage interval within 0.02 seconds while this voltage regulation speed value is obtained as 0.11 seconds without SVC. Considering CBEMA and ITIC curves that describe the tolerable input voltage range for equipment [21], this condition presents a considerable regulation in voltage standards. This issue can clearly be seen on the CBEMA curve given in Fig. 6. After the fault, the voltage raises to 145% of its nominal value. The system without SVC can recover this voltage raise to the nominal value in 80 ms while the system with SVC lowers this value to 1 ms as seen in Fig. 6. If the system did not provide a voltage regulation within the CBEMA and ITIC curves, the equipment connected, the relevant network would fail and the distribution company

would have to compensate the relevant damage on the mentioned equipment. The response time of the realized study to fault conditions is lower compared to [9]. The voltage is also regulated close to its nominal value faster than [10]. This issue is provided by the effective performance of the algorithm for reactive power regulation presented in Fig. 7.

The high values of reactive power occurring after the fault are decreased to significantly lower levels with the reactive power controlled SVC employed in the system as seen in Fig. 7. Besides, the reactive power value is maintained in steady state values rapidly after the fault and the required active power is supplied by the WECS instead of grid. The peak reactive power without SVC reaches to 1.4 MVar while this value is lowered to 0.8 MVar by employing the SVC unit with a reactive power suppression of nearly 45%. It is to be noted that this variation is also suitable for the reactive power grid code previously given in Fig. 4. The overloading of the grid is prevented and the WECS help the system while recovering to steady state by operating the WECS close to the full capacity. Accordingly, the active power varies as shown in Fig. 8.

During and just after the fault, especially the voltage variations at the nearest and remotest buses to the faults show importance. Thus, it can be possible to analyse the impacts of the fault on WECS and grid. After the fault occurring between 675-692 buses close to the WECS, the voltage variations of three points are presented in Fig. 9. The most significant issue while analysing the voltage variations at the nearest bus (bus 675), a comparatively close bus (bus 632) and the remotest bus (bus 650) to the fault, the nominal voltage regulation is rapidly obtained after the fault with the use of SVC. Thus, the WECS is affected comparatively lower and reaches to nominal operating conditions more rapidly.

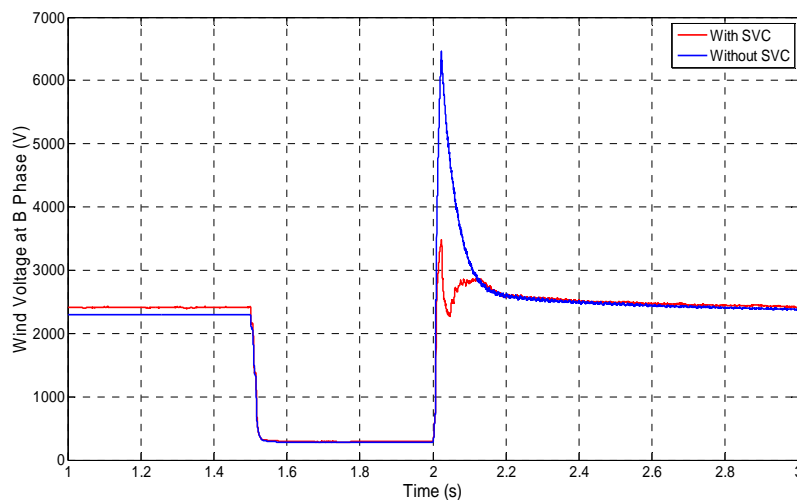

Fig. 5 The voltage variation at phase B of WECS grid connection point

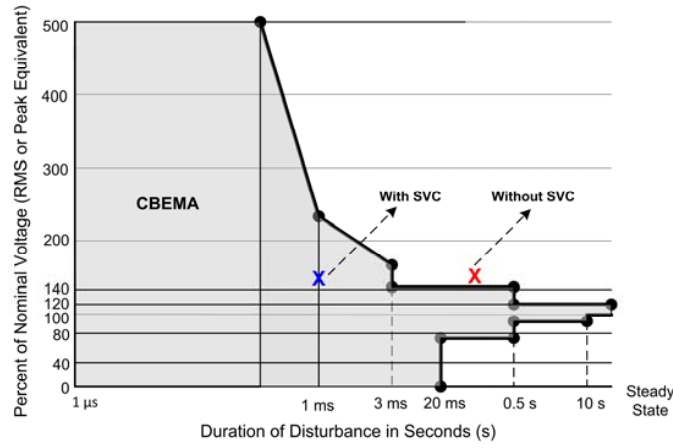

Fig. 6 The performance of the system on the CBEMA curve

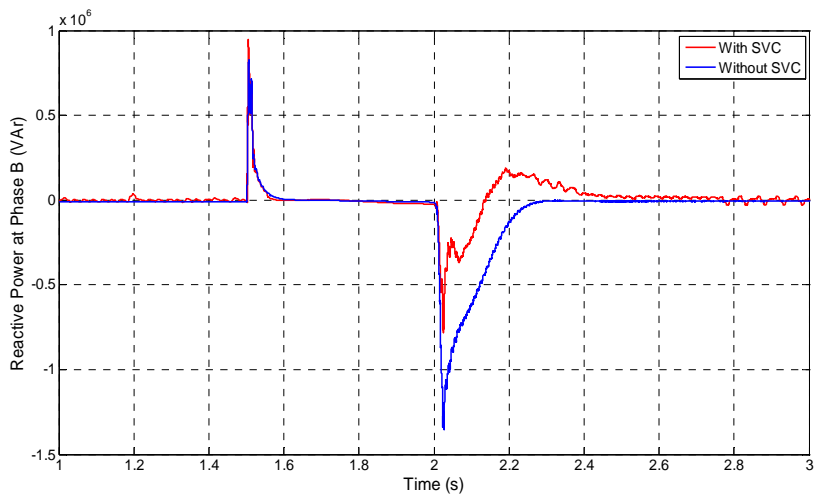

Fig. 7 The reactive power variation at phase B of WECS grid connection point

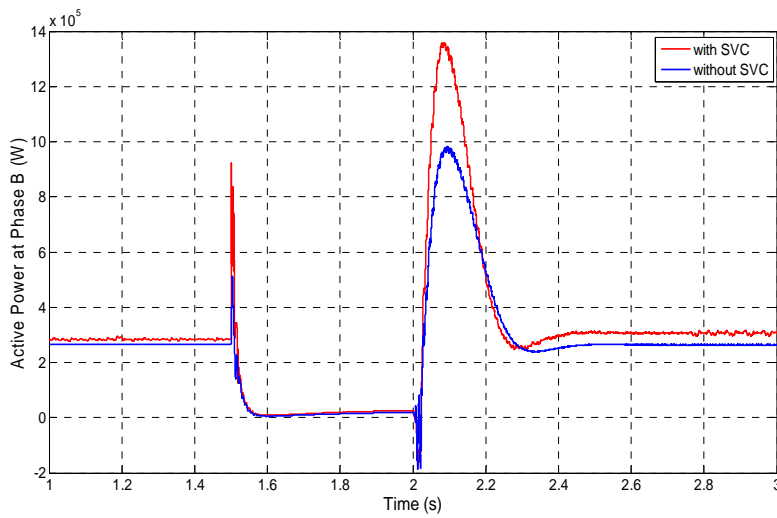
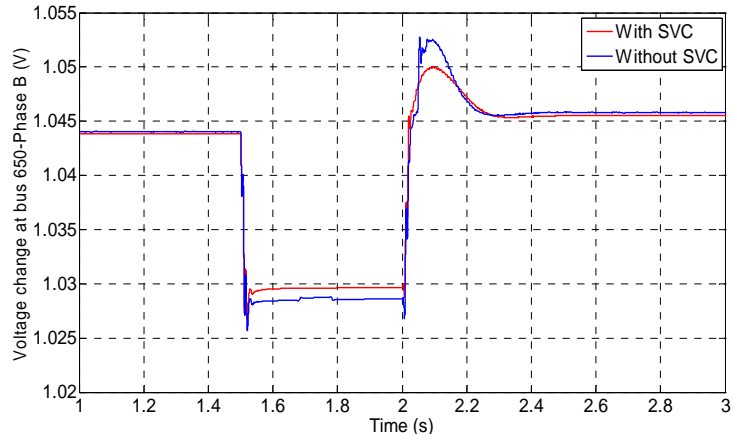
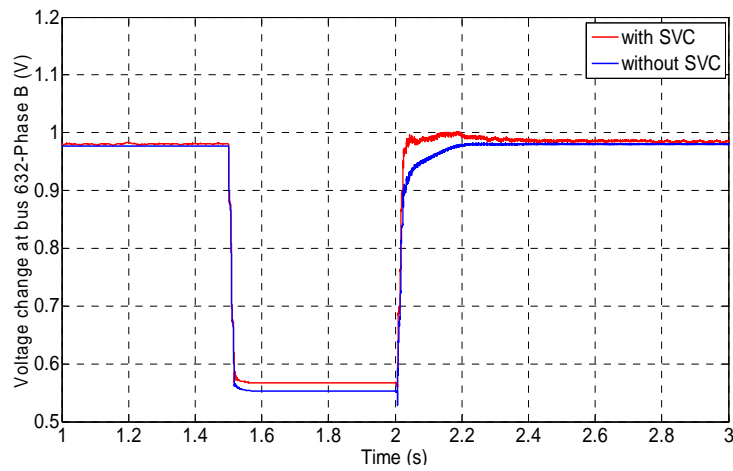

Fig. 8 The active power variation at phase B of WECS grid connection point



(a)



(b)

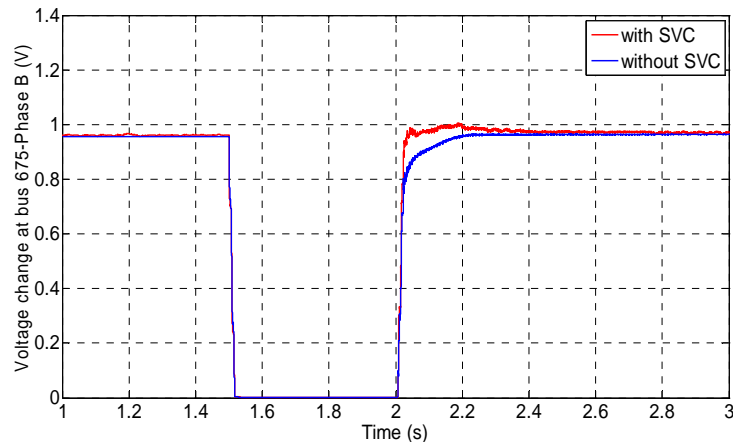

(c)

Fig. 9 The voltage variation of different test system bus points (from furthest to nearest considering WECS grid connection point) (a) Bus 650, (b) Bus 632, (c) Bus 675

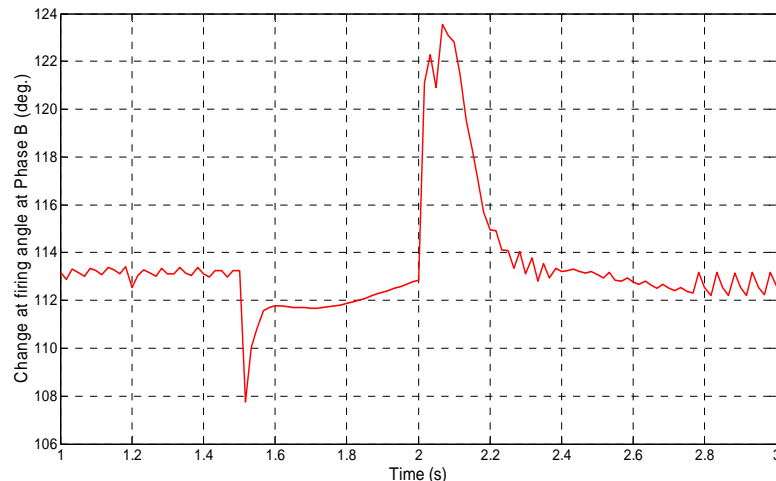

Fig. 10 The firing angle variation of SVC

#### IV. CONCLUSIONS

This paper presents a SVC based reactive power regulation of a WECS during fault conditions. The IEEE 13 node test system is employed for the performance evaluation. A 1.375 MW WECS unit connected to IEEE 13 node test system is considered in the current study and the SVC performance is discussed for a three phase short circuit condition.

It is clear from the results that the WECS unit is continuously operated even during the fault conditions with the employment and control of the SVC system. A significant reduction in voltage variation and reactive power requirements is obtained with the proposed structure. A reduction in transient voltage variation reaching to 40% is obtained with the proposed strategy. On the other hand, the active power production capability of WECS after fault condition is increased in this regard as seen from the reactive power regulation results compared to the case without the utilization of SVC and the control unit. The obtained values are suitable for international standard requirements and considerable for large scale systems. The future of this study lies in the adaptation of smart grid structure to the provided system in terms of adaptive relay coordination.

#### REFERENCES

- [1] A. Hepbasli, "A Key Review on Exergetic Analysis and Assessment of Renewable Energy Resources for a Sustainable Future", *Renew Sust Energy Reviews*, Vol. 12, no. 3, pp. 593–661, 2008.
- [2] Z. Chen, F. Blaabjerg, "Wind Farm—A Power Source in Future Power Systems", *Renew Sust Energy Reviews*, Vol. 13, no. 6, pp. 1288–1300, 2009.
- [3] T. Ackermann, "Wind Power in Power Systems", John Wiley & Sons: Chichester, 2005.
- [4] A. Tascikaraoglu, M. Uzunoglu, B. Vural, O. Erdinc, "Power Quality Assessment of Wind Turbines and Comparison with Conventional Legal Regulations: A Case Study in Turkey", *Appl Energy*, Vol. 88, no. 5, pp. 1864–1872, 2011.
- [5] I. M. Alegría, J. Andreu, J. L. Martín, P. Ibañez, J. L. Villate, H. Camblong, "Connection Requirements for Wind Farms: A Survey on Technical Requirements and Regulation", *Renew Sust Energy Reviews*, vol. 11, no. 8, pp. 1858–1872, 200.
- [6] N. G. Hingorani, L. Gyugyi, "Understanding FACTS: Concepts and Technology of Flexible AC Transmission Systems", Wiley-IEEE Press, 2000.
- [7] A. Ajami, M. Armaghan, "Fixed Speed Wind Farm Operation Improvement Using Current-Source Converter Based UPQC", *Energy Conv Management*, Vol. 58, pp. 10–18, 2012.
- [8] D. Ramirez, S. Martinez, F. Blazquez, C. Carrero, "Use of STATCOM in Wind Farms with Fixed-Speed Generators for Grid Code Compliance", *Renew Energy*, Vol. 37, no. 1, pp. 202–212, 2012.
- [9] R. R. Peters, D. Muthumunib, T. Bartelc, H. Salehfara, M. Manna, "Static VAR Compensation of a Fixed Speed Stall Control Wind Turbine During Start-Up", *Elec Power Systems Res*, Vol. 80, no. 4, pp. 400–405, 2010.
- [10] M. M. Kyaw, V. K. Ramachandaramurthy, "Fault Ride through and Voltage Regulation for Grid Connected Wind Turbine", *Renew Energy*, Vol. 36, no. 1, pp. 206–215, 2011.
- [11] N. G. Boulaxis, S. A. Papathanassiou, M. P. Papadopoulos, "Wind Turbine Effect on the Voltage Profile of Distribution Networks", *Renew Energy*, vol. 25, no. 3, pp. 401–415, 2002.
- [12] Z. Chen, E. Spooner, "Grid Power Quality with Variable Speed Wind Turbines", *IEEE Trans Energy Convers*, vol. 16, no. 2, pp. 148–154, 2001.
- [13] M. H. J. Bollen, G. Olguin, M. Martins, "Voltage Dips at the Terminals of Wind Power Installations", *Wind Energy*, Vol. 8, no. 3, pp. 307–318, 2005.
- [14] F. A. Farret, M. G. Simoes, "Integration of Alternative Sources of Energy", New Jersey: John Wiley & Sons, 2006.
- [15] IEC 61400-21, Wind Turbine Generator Systems. Part 21: Measurement and Assessment of Power Quality Characteristics of Grid Connected Wind Turbines, 2001.
- [16] N. A. Lahacani, D. Aouzellag, B. Mendil, "Contribution to the Improvement of Voltage Profile in Electrical Network with Wind Generator Using SVC Device", *Renew Energy*, Vol. 35, no. 1, pp. 243–248, 2010.
- [17] A. R. Boynuegri, B. Vural, A. Tascikaraoglu, M. Uzunoglu, R. Yumurtaçlı, "Voltage Regulation Capability of a Prototype Static VAR Compensator for Wind Applications", *Appl Energy*, vol.93, pp. 422–431, 2012.
- [18] W. H. Kersting, "Radial Distribution Test Feeders", *IEEE Power Engineering Society Winter Meeting*, pp. 908–912, 2001.
- [19] P. Pourbeik, N. C. Raleigh, A. Bostrom, B. Ray, "Modeling and Application Studies for a Modern Static VarSystem Installation", *IEEE Trans Power Delivery*; Vol. 21, no. 1, pp. 368 – 377, 2006.
- [20] M. Alonso, H. Amaris, C. A. Ortega, "A Multiobjective Approach for Reactive Power Planning in Networks with Wind Power Generation", *Renewable Energy*. Vol. 37, pp.180–191, 2012.
- [21] A. H. Escribano, E. G. Lázaro, A. M. García, J. A. Fuentes, "Influence of Voltage Dips on Industrial Equipment: Analysis and Assessment", *Electrical Power and Energy Systems*, Vol. 41, no. 1, pp. 87–95, 2012.