

Sampled-Data Control for Fuel Cell Systems

H. Y. Jung, Ju H. Park, S. M. Lee

Abstract—Sampled-data controller is presented for solid oxide fuel cell systems which is expressed by a sector bounded nonlinear model. The proposed control law is obtained by solving a convex problem satisfying several linear matrix inequalities. Simulation results are given to show the effectiveness of the proposed design method.

Keywords—Sampled-data control, Sector bound, Solid oxide fuel cell, Time-delay.

I. INTRODUCTION

SOLID OXIDE FUEL CELL (SOFC) has attracted considerable interest as it offers wide application ranges, flexibility in the choice of fuel, high system efficiency and rapid load following capability [1]-[4]. In this regard, during the last several years, many researches have been investigated the dynamic model for simulating transient behavior as well as designing model-based controllers of the SOFC systems. In [1], a mathematical dynamic model for SOFC stack is simply presented. Its detailed model with temperature dynamics is developed in [5]. It is important to establish control over the fuel cell voltage because of its heavily nonlinear behavior and dependence on disturbances such as load current and inlet temperatures. However, these mathematical models have a difficulty on the controller design due to its complexity. Thus, based on the experimental input-output data, numerical modeling techniques such as support vector machine, T-S fuzzy, and neural network have been proposed in [3], [4]. In [3], a model predictive control method for SOFC systems is presented by use of a simplified dynamic model which is obtained by subspace identification method.

The previous studies have been conducted by use of input-output data based model for control of SOFC systems. It should be pointed out that sampled-data control scheme is very useful since it is possible to handle digital controller and increasing research efforts have been devoted to sampled-data control systems with the development of modern high-speed computers, microelectronics, and communication networks. Recently, the control technique has been applied to the SOFC systems due to its slow dynamics and tight operating constraints [4], [5]. In this paper, we consider a sector bounded nonlinear model to handle SOFC systems and propose a

sampled-data control method for the systems. The sector bounded nonlinear systems, which have a feedback connection with a linear dynamical system and nonlinearity satisfying certain sector type constraints, have been extensively studied in control theory research area. Since the pioneer work of Lur'e was presented in 1940', the notion of absolute stability has played an important role in stability analysis and controller design problems [6].

To the best of authors' knowledge, there are no approaches considering sampled-data for SOFC systems. The proposed nonlinear control method guarantee closed-loop stability, a stabilization criterion is proposed in terms of LMIs which can be solved very efficiently by convex algorithms [8].

Finally, we demonstrate the effectiveness of the proposed approach via numerical simulations.

II. PROBLEM STATEMENT

Consider the dynamics of an SOFC system [2] as shown in Fig. 1 and assume that all states are available. As a widely adopted dynamic model of the SOFC system, the average voltage magnitude of the fuel cell stack is determined by the partial pressure of hydrogen, oxide and water.

Table I contains the parameters of the SOFC model. Applying Nernst's equation, the output of the SOFC can be modeled as:

$$V_0 = N_0 [E_0 + \frac{R_0 T_0}{2F_0} \ln \frac{p_{H_2} (p_{H_2}/101.325)^{\frac{1}{2}}}{p_{H_2 O}}] \quad (1)$$

where p_{H_2} , p_{O_2} , $p_{H_2 O}$ are partial pressures of hydrogen, oxygen and water. Also, the dynamics of fuel processor and the stack voltage are:

$$\dot{q}_H = \frac{1}{\tau_H} (q_F - q_H) \quad (2)$$

$$\dot{V}_S = \frac{1}{r_C} (V_0 - V_S - r I_D) \quad (3)$$

where q_H is the hydrogen flow rate, q_F is inlet fuel flow rate, V_S is stack voltage and I_D is external current load that is assumed to be not changed.

The dynamic equation of the partial pressure inside the channel of hydrogen, oxygen and water are as:

$$\begin{aligned} \dot{p}_{H_2} &= \frac{1}{\tau_{H_2} K_{H_2}} (q_H - 2K_r I_s - p_{H_2} K_{H_2}), \\ \dot{p}_{O_2} &= \frac{1}{\tau_{O_2} K_{O_2}} \left(\frac{q_H}{\tau_{H-O}} - K_r I_s - p_{O_2} K_{O_2} \right) \\ \dot{p}_{H_2 O} &= \frac{1}{\tau_{H_2 O} K_{H_2 O}} (2K_r I_s - p_{H_2 O} K_{H_2 O}), \end{aligned} \quad (4)$$

H.Y. Jung is with the Department of Information and Communication Engineering, Yeungnam University, 214-1 Dae-Dong, Gyeongsan 712-749, Republic of Korea (e-mail: hoyoul@yu.ac.kr).

Ju H. Park is with the Department of Electrical Engineering, Yeungnam University, 214-1 Dae-Dong, Gyeongsan712-749, Republic of Korea (e-mail: jessie@ynu.ac.kr).

S.M. Lee is with the Electronic Engineering Department, Daegu University, Jinrang-eup, Gyeongsan 712-714, Republic of Korea (corresponding author phone: +82-53-850-6647; e-mail: moony@daegu.ac.kr).

where $I_S = (V_o - V_s)/r$ is stack current.

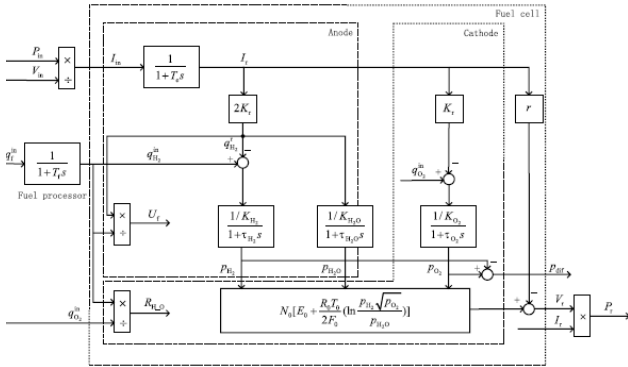

Fig. 1 Solid oxide fuel cell (SOFC) system dynamic model

In order to transform states around its equilibrium point, let us define the following states and input:

$$\begin{aligned} x_1 &= p_{H_2} K_{H_2} - p_{H_2}^* K_{H_2}, \\ x_2 &= p_{O_2} K_{O_2} - p_{O_2}^* K_{O_2}, \\ x_3 &= q_H - q_H^* \\ x_4 &= V_S - V_S^* \\ u &= q_F - q_F^*, I_D = I_D^*, p_{H_2O} = p_{H_2O}^* \end{aligned} \quad (5)$$

where $p_{H_2}^*$, $p_{O_2}^*$, q_H^* , V_S^* , q_F^* , I_D^* , $p_{H_2O}^*$ are operating points of each states.

It should be noted that the pressure of water p_{H_2O} has constant value because external current load I_D is assumed to be not changed in this paper.

Then, the variation of the stack current is expressed as:

$$\begin{aligned} I_S - I_S^* &= \frac{1}{r} (V_o - V_o^* - (V_S - V_S^*)) \\ &= \frac{1}{r} \left[\frac{N_0 R_0 T_0}{2F_0} \left(\ln \left(\frac{p_{H_2}}{p_{H_2}^*} \right) + \frac{1}{2} \ln \left(\frac{p_{O_2}}{p_{O_2}^*} \right) \right) - (V_S - V_S^*) \right] \\ &= \frac{1}{r} \left[\frac{N_0 R_0 T_0}{2F_0} \left(\ln \left(\frac{x_1 / K_{H_2} + p_{H_2}^*}{p_{H_2}^*} \right) + \frac{1}{2} \ln \left(\frac{x_2 / K_{O_2} + p_{O_2}^*}{p_{O_2}^*} \right) \right) - x_4 \right] \end{aligned} \quad (6)$$

Therefore, the transformed state space model is described as:

$$\dot{x}(t) = A_C x(t) + F_C g(x(t)) + B_C u(t), \quad (7)$$

where $x(t) = [x_1 \ x_2 \ x_3 \ x_4]^T \in R^n$ is the states, $u(t)$ is the fuel flow rate,

$$A_C = \begin{bmatrix} -\frac{1}{\tau_{H_2}} & 0 & -\frac{1}{\tau_{H_2}} & \frac{2K_F}{r\tau_{H_2}} \\ 0 & -\frac{1}{\tau_{O_2}} & \frac{1}{\tau_{H_2}\tau_{O_2}} & \frac{K_F}{r\tau_{O_2}} \\ 0 & 0 & -\frac{1}{\tau_f} & 0 \\ 0 & 0 & 0 & -\frac{1}{rC} \end{bmatrix}, B_C = \begin{bmatrix} 0 \\ 0 \\ \frac{1}{\tau_f} \\ 0 \end{bmatrix}, F_C = \begin{bmatrix} -\frac{2K_F}{r\tau_{H_2}} \\ -\frac{K_F}{r\tau_{O_2}} \\ 0 \\ \frac{1}{rC} \end{bmatrix},$$

$$g(x(t)) = \begin{bmatrix} \frac{N_0 R_0 T_0}{2F_0} & \frac{N_0 R_0 T_0}{4F_0} \end{bmatrix} \begin{bmatrix} \ln \left(\frac{x_1 + p_{H_2}^* K_{H_2}}{p_{H_2}^* K_{H_2}} \right) \\ \ln \left(\frac{x_2 + p_{O_2}^* K_{O_2}}{p_{O_2}^* K_{O_2}} \right) \end{bmatrix} \quad (8)$$

In order to design a control law, consider the following sampled-data state feedback controller:

$$u(t) = Kx(t_k) \quad (9)$$

In this paper, the control signal is assumed to be generated by using a zero-order-hold (ZOH) function with a sequence of hold time $0 \leq t_0 < t_1 < \dots < t_k \dots < \lim_{k \rightarrow \infty} t_k = +\infty$.

Also, the sampling is not required to be periodic, and the only assumption is that the distance between any two consecutive sampling instants is less than a given bound. Specially, it is assumed that:

$$t_{k+1} - t_k \leq h,$$

for all $k \geq 0$, where h represents the upper bound of the sampling periods.

Define $d(t) = t - t_k$ and $t_k = t - (t - d(t))$, then the system (7) can be represented as:

$$\begin{aligned} \dot{x}(t) &= A_C x(t) + F_C f(q(t)) + B_C Kx(t-d(t)), \\ q(t) &= Cx(t) \end{aligned} \quad (10)$$

III. MAIN RESULT

In this section, we derive a LMI condition for sampled-data controller design for Lur'e system with sector nonlinearities. For the simplicity on matrix representation, $e_i \in \mathfrak{R}^{7 \times n}$ ($i=1,2,\dots,n$), e.g., $e_2 = [0_n, I_n, 0_n, 0_n, 0_n, 0_n]$ and the augmented vectors are defined as:

$$\begin{aligned} x_a^T(t) &= [x^T(t) \quad f^T(v(t))], \\ \xi^T(t) &= [x^T(t) \quad f^T(v(t)) \quad x^T(t-h(t)) \quad f^T(v(t-h(t))) \\ &\quad x^T(t-h) \quad f^T(v(t-h)) \quad \dot{x}^T(t) \quad \dot{f}^T(v(t))] \end{aligned}$$

and define the matrices:

$$\begin{aligned} \hat{\Xi}_1 &= [e_1 \ e_2] \hat{\mathcal{P}} [e_7 \ e_8]^T + [e_7 \ e_8] \hat{\mathcal{P}} [e_1 \ e_2]^T, \\ \hat{\Xi}_2 &= [e_1 \ e_2] \hat{\mathcal{Q}} [e_1 \ e_2]^T + [e_5 \ e_6] \hat{\mathcal{Q}} [e_5 \ e_6]^T, \\ \hat{\Xi}_3 &= h^2 [e_7 \ e_8] \hat{\mathcal{R}} [e_7 \ e_8]^T \\ &\quad - [e_1 - e_3 \ e_2 - e_4 \ e_3 - e_5 \ e_4 - e_6] \begin{bmatrix} \hat{\mathcal{R}} & \hat{\mathcal{S}} \\ * & \hat{\mathcal{R}} \end{bmatrix} \\ &\quad [e_1 - e_3 \ e_2 - e_4 \ e_3 - e_5 \ e_4 - e_6]^T, \\ \Phi &= [AG \ FG \ BT \ 0 \ 0 \ 0 \ -G \ 0], \\ T &= KG, \end{aligned}$$

$$\begin{aligned} \Lambda &= \text{diag}\{\Lambda_1(v_1(t)), \Lambda_2(v_2(t)), \dots, \Lambda_m(v_m(t))\}, \\ \bar{\Lambda} &= \text{diag}\{\bar{\Lambda}_1(v_1(t)), \bar{\Lambda}_2(v_2(t)), \dots, \bar{\Lambda}_m(v_m(t))\}, \\ \Delta_1 &= \text{diag}\{b_1, b_2, \dots, b_m\}, \Delta_2 = \text{diag}\{a_1, a_2, \dots, a_m\}, \\ \bar{\Delta}_1 &= \text{diag}\{\bar{b}_1, \bar{b}_2, \dots, \bar{b}_m\}, \bar{\Delta}_2 = \text{diag}\{\bar{a}_1, \bar{a}_2, \dots, \bar{a}_m\}, \end{aligned}$$

Then, the nonlinear function $f(v(t))$ and $\dot{f}(v(t))$ can be expressed as:

$$f(v(t)) = \Lambda v(t), \quad \dot{f}(v(t)) = \bar{\Lambda} \dot{v}(t), \quad (11)$$

and the parameters $\Lambda, \bar{\Lambda}$ belong to the following set:

$$\Phi := \{(\Lambda, \bar{\Lambda}) \mid \Lambda \in \text{Co}\{\Delta_1, \Delta_2\}, \bar{\Lambda} \in \text{Co}\{\bar{\Delta}_1, \bar{\Delta}_2\}\} \quad (12)$$

Theorem 1. For given positive scalars h and δ , the system (7) with the sampled-data controller (9) is stable, if there exist symmetric positive definite matrices $\mathcal{P} \in \mathcal{R}^{2n \times 2n}, \mathcal{Q} \in \mathcal{R}^{2n \times 2n}$ any matrices $\mathcal{S} \in \mathcal{R}^{2n \times 2n}$ symmetric matrices $G \in \mathcal{R}^{n \times n}$ and appropriate dimension matrix T satisfying the following LMIs:

$$\sum_{i=1}^4 \hat{\Xi}_i - 2e_2 G^{-1} e_2^T + e_2 G^{-1} \Lambda D e_1^T + e_1 D^T \Lambda^T G^{-1} e_2^T - 2e_8 G^{-1} e_8^T + e_8 G^{-1} \bar{\Lambda} D e_7^T + e_7 D^T \bar{\Lambda}^T G^{-1} e_8^T (e_1 + \delta e_7) G^{-1} \Phi G^{-1} + G^{-1} \Phi^T G^{-1} (e_1 + \delta e_7)^T < 0 \quad (13)$$

$$\begin{bmatrix} \hat{\mathcal{R}} & \hat{\mathcal{S}} \\ * & \hat{\mathcal{R}} \end{bmatrix} \geq 0. \quad (14)$$

Further, the sampled-data controller gain matrix in (9) is given by:

$$K = T G^{-1}. \quad (15)$$

Proof. Consider the following Lyapunov function candidate:

$$V(t) = \sum_{i=1}^3 V_i \quad (16)$$

where

$$\begin{aligned} V_1 &= x_a^T(t) \mathcal{P} x_a(t), \\ V_2 &= \int_{t-h}^t x_a^T(s) \mathcal{Q} x_a(s) ds, \\ V_3 &= h \int_{-h}^0 \int_{t+\alpha}^t \dot{x}_a^T(s) \mathcal{R} \dot{x}_a(s) ds. \end{aligned}$$

The time-derivative of the Lyapunov function $V(t)$ can be obtained as:

$$\dot{V}_1 = \dot{x}_a^T(t) \mathcal{P} x_a(t) + x_a^T(t) \mathcal{P} \dot{x}_a(t) = \xi^T(t) \Xi_1 \xi(t), \quad (17)$$

where

$$\begin{aligned} \Xi_1 &= [e_1 \ e_2] \mathcal{P} [e_7 \ e_8]^T + [e_7 \ e_8] \mathcal{P} [e_1 \ e_2]^T, \\ \dot{V}_2 &= x_a^T(t) \mathcal{Q} x_a(t) - x_a^T(t-h) \mathcal{Q} x_a(t-h) = \xi^T(t) \Xi_2 \xi(t) \end{aligned} \quad (18)$$

where

$$\begin{aligned} \Xi_2 &= [e_1 \ e_2] \mathcal{Q} [e_1 \ e_2]^T - [e_5 \ e_6] \mathcal{Q} [e_5 \ e_6]^T, \\ \dot{V}_3 &= h^2 \dot{x}_a^T(t) \mathcal{R} \dot{x}_a(t) - h \int_{t-h}^t \dot{x}_a^T(s) \mathcal{R} \dot{x}_a(s) ds, \end{aligned} \quad (19)$$

Since $\begin{bmatrix} \hat{\mathcal{R}} & \hat{\mathcal{S}} \\ * & \hat{\mathcal{R}} \end{bmatrix} \geq 0$, by employing Jensen's inequality and the reciprocally convex combination technique [7], one can obtain:

$$-h \int_{t-h}^t \dot{x}_a^T(s) \mathcal{R} \dot{x}_a(s) ds \leq \begin{bmatrix} \int_{t-h(t)}^t \dot{x}_a(s) ds \\ \int_{t-h}^{t-h(t)} \dot{x}_a(s) ds \end{bmatrix}^T \begin{bmatrix} \hat{\mathcal{R}} & \hat{\mathcal{S}} \\ * & \hat{\mathcal{R}} \end{bmatrix} \begin{bmatrix} \int_{t-h(t)}^t \dot{x}_a(s) ds \\ \int_{t-h}^{t-h(t)} \dot{x}_a(s) ds \end{bmatrix} \quad (20)$$

Hence, from (19) and (20), we have

$$\dot{V}_3 \leq \xi^T(t) \Xi_3 \xi(t), \quad (21)$$

where

$$\begin{aligned} \Xi_3 &= h^2 [e_7 \ e_8] \mathcal{R} [e_7 \ e_8]^T - [e_1 - e_3 \ e_2 - e_4 \ e_3 - e_5 \ e_4 - e_6] \\ &\quad \mathcal{R} [e_1 - e_3 \ e_2 - e_4 \ e_3 - e_5 \ e_4 - e_6]^T, \end{aligned}$$

From (11) and (10), for any symmetric matrices G , the following equations are satisfied:

$$2f^T(v(t)) G^{-1} [\Lambda D \quad -I \quad 0 \quad 0 \quad 0 \quad 0 \quad 0 \quad 0] \xi(t) = 0, \quad (22)$$

$$2\dot{f}^T(v(t)) G^{-1} [0 \quad 0 \quad 0 \quad 0 \quad 0 \quad 0 \quad \bar{\Lambda} D \quad -I] \xi(t) = 0, \quad (23)$$

$$\begin{aligned} 2[x^T(t) G^{-1} + \delta \dot{x}^T(t) G^{-1}] [A \ F \ BK \ 0 \ 0 \ 0 \ -I \ 0] \xi(t) \\ = \xi^T(t) ((e_1 + \delta e_7) G^{-1} \Phi G^{-1} \\ + G^{-1} \Phi^T G^{-1} (e_1 + \delta e_7)^T) \xi(t) = 0, \end{aligned} \quad (24)$$

An upper bound of the difference of $V(t)$ is:

$$\begin{aligned} \dot{V}(t) \leq \xi^T(t) (\sum_{i=1}^3 \hat{\Xi}_i - 2e_2 G^{-1} e_2^T + e_2 G^{-1} \Lambda D e_1^T + e_1 D^T \Lambda^T G^{-1} e_2^T - 2e_8 G^{-1} e_8^T + \\ e_8 G^{-1} \bar{\Lambda} D e_7^T + e_7 D^T \bar{\Lambda}^T G^{-1} e_8^T (e_1 + \delta e_7) G^{-1} \Phi G^{-1} + G^{-1} \Phi^T G^{-1} (e_1 + \delta e_7)^T) \xi(t) \end{aligned} \quad (25)$$

Let us define

$$\begin{aligned} \hat{\mathcal{P}} &= \text{diag}\{G, G\}^T \mathcal{P} \text{diag}\{G, G\} \\ \hat{\mathcal{Q}} &= \text{diag}\{G, G\}^T \mathcal{Q} \text{diag}\{G, G\} \\ \hat{\mathcal{R}} &= \text{diag}\{G, G, G, G\}^T \mathcal{R} \text{diag}\{G, G, G, G\}, \\ \hat{\mathcal{S}} &= \text{diag}\{G, G\}^T \mathcal{S} \text{diag}\{G, G\}, \end{aligned}$$

then pre and post multiplying the matrix $\text{diag}\{G, \dots, G\}^T$ and $\text{diag}\{G, \dots, G\}$ in (25) leads to LMI (13). This completes the proof.

TABLE I
PARAMETERS IN THE SOFC SYSTEM [6]

Parameter	Value Unit	Representation
T_0	1279K	Absolute temperature
F_0	96,485Cmol ⁻¹	Faraday's constant
R_0	8.314Jmol ⁻¹ K ⁻¹	Universal gas constant
E_0	0:9378 V	Ideal standard potential
N_0	384 -	Number of cells n series in the
K_r	0.995 × 10 ⁻³ mol s ⁻¹ A ⁻¹	Constant, Kr = N0=4F0
K_{H_2}	8.32 × 10 ⁻³ mol s ⁻¹ KPa ⁻¹	Valve molar constant for hydrogen
K_{H_2O}	2.77 × 10 ⁻³ mol s ⁻¹ KPa ⁻¹	Valve molar constant for water
K_{O_2}	2.49 × 10 ⁻³ mol s ⁻¹ KPa ⁻¹	Valve molar constant for oxygen
τ_{H_2}	26.1 s	Response time of hydrogen flow
τ_{O_2}	2.91 s	Response time of Oxygen flow
τ_{H-O}	1.145	Ratio of hydrogen to oxygen
τ_f	5 s	Time constant of the fuel processor
r	0.126Ω	Ohmic loss
C	10 F	Parallel Capacitance

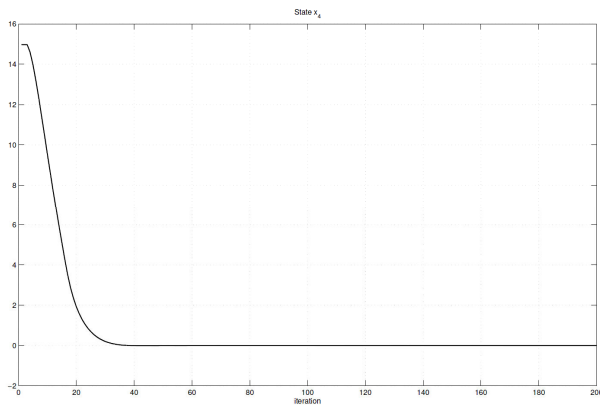
Fig. 2 Simulation result (Stack voltage $x_4(t)$)

IV. SIMULATION RESULT

Using the state transformation around the nominal operation point with $q_F^* = 0.7023 \text{ mol s}^{-1}$, $I_D^* = 300 \text{ A}$, $V_s^* = 240.7075 \text{ V}$, $p_{H_2}^* = 12.6623$, $p_{O_2}^* = 12.6466$ and Euler's first order approximation with a sampling time 1 sec for the derivative, we obtain a sector bounded system (1) with the following matrices.

$$\begin{aligned}
 A &= \begin{bmatrix} -0.0383 & 0 & 0.0383 & 0.0006 \\ 0 & -0.3436 & 0.3001 & 0.0027 \\ 0 & 0 & -0.2000 & 0 \\ 0 & 0 & 0 & -0.7937 \end{bmatrix}, \\
 B &= \begin{bmatrix} 0 \\ 0 \\ 0.2000 \\ 0 \end{bmatrix}, \quad F = \begin{bmatrix} -0.0128 & -0.0064 \\ -0.0572 & -0.0286 \\ 0 & 0 \\ 16.7151 & 8.3576 \end{bmatrix}, \\
 C &= \begin{bmatrix} 1 & 0 & 0 & 0 \\ 0 & 1 & 0 & 0 \end{bmatrix}, \\
 f(x(k)) &= \begin{bmatrix} \ln\left(\frac{x_1(t) + p_{H_2}^* K_{H_2}}{p_{H_2}^* K_{H_2}}\right) \\ \ln\left(\frac{x_2(t) + p_{O_2}^* K_{O_2}}{p_{O_2}^* K_{O_2}}\right) \end{bmatrix}, \\
 \Delta(k) &\in \left\{ \begin{bmatrix} 6.67 & 0 \\ 0 & 2.83 \end{bmatrix}, \begin{bmatrix} 9.07 & 0 \\ 0 & 3.52 \end{bmatrix} \right\}. \quad (26)
 \end{aligned}$$

It should be noted that lower and upper sector bounds of the nonlinear function vector $f(x(t))$ are obtained as $[6.67 \ 2.83]^T$ and $[9.07 \ 3.52]^T$ in $x_1 \in [0 \ 0.1]$. The initial condition is $x_0 = [0.0867 \ 0.0777 \ 0.0898 \ 14.9727]^T$. Fig. 1 show that the proposed method with the case of only state feedback control law. This results show that the proposed method can be well applied to the set-point tracking.

V. CONCLUSION

In this paper, we proposed a sampled-data control algorithm for SOFC systems using a sector bounded nonlinear model. A stabilization condition by using the augmented vector feedback is expressed in the form of a finite number of LMIs. The proposed control method was applied to the SOFC system which is expressed as simplified mathematical model. The effectiveness of the proposed method was verified by numerical simulations.

ACKNOWLEDGMENT

This research was supported by Basic Science Research Program through the National Research Foundation of Korea (NRF) funded by the Ministry of Education, Science and Technology (2014R1A1A4A01003860).

REFERENCES

- [1] J. Padull_es, G.W. Ault, J.R. Mcdonald, An integrated SOFC plant dynamic model for power systems simulation, *Journal of Power Sources*, vol. 86, pp. 495-500, 2000.
- [2] F. Mueller, F. Jabbari, R. Gaynor, J. Brouwer, Novel solid oxide fuel cell system controller for rapid load following, *Journal of Power Sources*, vol. 172, pp. 208-323, 2007.
- [3] X. Wang, B. Huang, T. Chen, Data-driven predictive control for solid oxide fuel cells, *Journal of Process Control*, vol. 17, pp. 103-114, 2007.
- [4] Jie Yang, Xi Li, Hong-Gang Mou, Li Jian, Predictive control of solid oxide fuel cell based on an improved Takagi-Sugeno fuzzy model, *Journal of Power Sources*, vol. 193, pp. 699-705, 2009.
- [5] A.M. Murshed, Biao Huang., K. Nandakumar, Estimation and control of solid oxide fuel cell system, *Computers and Chemical Engineering*, vol. 34, pp. 96-111, 2010.
- [6] T. Zhang, G. Feng, Rapid Load Following of an SOFC Power System via Stable Fuzzy Predictive Tracking Controller, *IEEE Trans. Fuzzy Syst.*, vol. 17, no. 2, 2009.
- [7] P. Park, J. W. Ko, and C. Jeong, Reciprocally convex approach to stability of system with time-varying delays, *Automatica*, vol. 47, no. 1, pp. 235-238, Jan. 2011.
- [8] S. Boyd, L. E. Ghaoui, E. Feron, & V. Balakrishnan, *Linear matrix inequalities in system and control theory*, Philadelphia., SIAM., 1994.