

# EyeBall Motion Controlled Wheelchair Using IR Sensors

Monika Jain, Shikhar Puri, Shivali Unishree

**Abstract**—This paper presents the ‘Eye Ball Motion Controlled Wheelchair using IR Sensors’ for the elderly and differently abled people. In this eye tracking based technology, three Proximity Infrared (IR) sensor modules are mounted on an eye frame to trace the movement of the iris. Since, IR sensors detect only white objects; a unique sequence of digital bits is generated corresponding to each eye movement. These signals are then processed via a micro controller IC (PIC18F452) to control the motors of the wheelchair. The potential and efficiency of previously developed rehabilitation systems that use head motion, chin control, sip-n-puff control, voice recognition, and EEG signals variedly have also been explored in detail. They were found to be inconvenient as they served either limited usability or non-affordability. After multiple regression analyses, the proposed design was developed as a cost-effective, flexible and stream-lined alternative for people who have trouble adopting conventional assistive technologies.

**Keywords**—Eye tracking technology, Intelligent wheelchair, IR module, rehabilitation technology.

## I. INTRODUCTION

THE ability to exercise freedom of mobility affects an individual’s sense of dignity and confidence. If Census 2001 is to be believed, of the 2.1 percent of India’s disabled, 0.6 percent (equivalent to almost 61 lakhs) is suffering from movement disability [1]. This statistic has supposedly increased prolifically in the last decade. When it comes to adopting the right assistive technology (whether prostheses or orthoses), people are either unable to afford or are faced with a myriad of logistic inefficiencies. As an upshot, most of the victims are unable to contribute financially or socially and are depended on their families/caregivers’ charity, making concessions with their own dignity. Since the degree of disability is a variable and specialized needs of each person are different, it is highly unlikely a universal model can ever be developed that is also cost-effective. As such the market for technology-aided human support systems is quite small, governed by archaic rules and limited resource knowledge. Though the recent introduction of ‘Rights of Persons with Disabilities Bill, 2014’ (in addition to the already existing Disability Act, 1995) [2] increases the ambit of the disabled people, the absence of a more comprehensive Assistive Technology Act causes a chronic non-use, abandonment and discontinuance of rehabilitation technology. Since most disabled people view their assistive devices as an extension of

themselves, it has become a subject of utmost necessity to develop devices that users can successfully integrate into their lifestyle. A large variety of electric powered wheelchairs that use different human machine interfaces (HMI) such as head motion, chin control, sip-n-puff control, voice recognition and EEG signals, are available. Chin control technology uses a force-sensing joystick shaft that doesn’t require very accurate head movements [3]. A little different direction of force each time suffices in moving the wheelchair in different directions. The force required is generally in the range of 0.2 to 0.8 pounds (0.09 to 0.3 kilograms) [3]. This technology can only be adopted by people possessing substantial strength in their neck muscles. Sip-n-puff devices are controlled by commands given by sipping (inhaling) and puffing (exhaling) on a pneumatic tube [4]. Sharp sips and puffs can be used to change the direction of the wheelchair while the steering can be accomplished by lower/softer levels of sips and puffs [4]. These devices are mainly equipped for speed control and require a considerable accuracy in the sips and puffs each time. They are also limited by the fact that they require an external source of start. The TTK (tongue touch keypad) is the only commercially available tongue controller system. It consists of 9 switches built into the dental mouthpiece and fits in the roof of the mouth [5]. Users can adjust the wheelchair speed by touching the front and back pads variedly [5]. A major limitation of such a controller is that they have to be constantly removed before eating and even drinking water. It can prove to be quite a discomfort to be constantly worn inside the mouth. EOG (electrooculography) technology measures the electric potential difference between the cornea and the pupil, with respect to a reference electrode placed on the forehead [6]. 5 more electrodes are placed near the eye to detect eyeball rotation [6]. A change of 20 microvolts is measured for each degree of eye movement [7]. Changing light conditions have negligent effect on EOG signals but they are prone to signal noise and drifting [8]. The variability of the electrooculogram reading depends on many difficult-to-measure factors such as perturbations caused by other biopotentials like EEG, ECG, EMG (electromyogram) [11] plus those caused due to the positioning of electrodes, skin-electrode contacts, lighting conditions, head movements, blinking, etc. [7], [10]. The major limitations are the barely deterministic variables measured in the human body as well as the persistent problem of the Midas’s Touch - *the human eye is always ON* [7]. As a result, everywhere the user looks, a command is activated. EOG control systems require a high degree of supervision [8]. VOG (video oculography) is another eye tracking system that uses head mounted cameras

Dr. Monika Jain, Mr. Shikhar Puri, and Ms. Shivali Unishree are with the Department of Instrumentation and Control Engineering, Galgotias College of Engineering & Technology, Greater Noida, India (e-mail: monikajain.bits@gmail.com, gamerpuri@gmail.com, shivaliunishree06balsree@gmail.com)

to analyze the gaze data and record the user's point of view [7]. The video images are the basis for estimating the working distance and gaze quality [9]. There are a number of issues that affect the quality of VOG tracking, such as droopy eyelids, squinting while smiling, varying light conditions, sweat and even make-up [9]. Since the eyes are connected to the balance organs in the inner ear it is necessary to observe the fine eye movements in various head positions, in order to make a correct diagnosis [7]. For accurate calculation of the gaze vector the user must be very still which can become quite uncomfortable [14]. The most advanced rehabilitation technology is perhaps the EEG (electro-encephalogram) controlled system that uses brain signals to calibrate the movement of the wheelchair [5]. Brain patterns are generated by attaching electrodes to the user's brains that map the signals such as if the user is thinking left motion, the wheelchair will move left [6]. A very advanced model based on EEG signals is the Intel connected wheelchair designed for the physicist Stephen Hawking. It can not only control mobility by thoughts but can also translate them into computer generated words. This Brain Computer Interface (BCI) acquires and analyses brain signals to calibrate the computer to the specific electrical signals generated by different thoughts [15], [16]. Such rehabilitation technology, though highly effective, is extremely expensive, requires continuous calibrations through the years and is hardly used to facilitate the majority. We have devised a new design based on eye tracking technology that has rapid computational speed, high accuracy and is cost-effective.

## II. PROPOSED MODEL

Eye-tracking involves the 'tracking of eye movements'. It is a method where the scan path of a person's gaze, while looking over a picture or in a particular direction, is traced and recorded [12]. In other words, the sequence of when and how long the test subject gazes on a particular area of the image is being measured.

Eye tracking has been perceived to be a very accurate platform for the building of rehabilitation technologies. It offers a powerful research tool for developmental scientists. Eye records precisely what people perceive and what not [17]. Eye tracking has helped provide detailed, quantitative data to the usability testing process. Most eye-trackers are designed to detect saccades and fixations. Other types of eye movements that are a frequent occurrence are the smooth-pursuit (for tracking slow-moving visual targets), the vestibulo-ocular reflex (for compensating head movements) and the vergence (for obtaining binocular vision) [13]. Not all eye tracking devices can correctly measure and identify the different types of eye movements and not all eye movements can be correctly measured. Therefore, they must be properly controlled in experiments. The use of infrared technology plays a critical role in eye tracking as it allows one to draw connections from a psychological perspective between eye-movement data and neurological processes in the brain.

In this proposed design, an eye mounted frame has been developed that is worn like spectacles shown in Fig. 1.

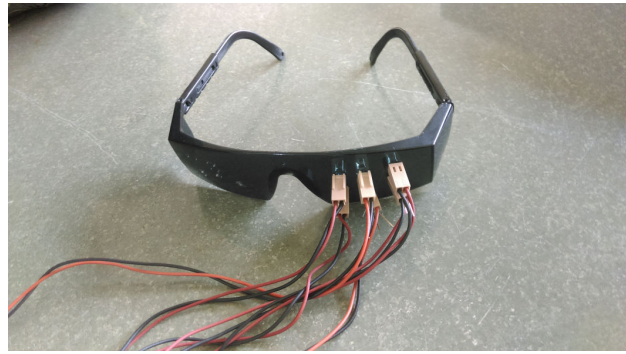

Fig. 1 Photograph of Eye-gear

Three pairs of IR sensors have been drilled into it. With the help of a single eye (with or without vision), a wheelchair can be commanded. IR sensor modules emit a continuous beam of IR rays. Whenever a white object (obstacle) comes in front of the receiver, these rays are reflected back and captured. When faced with a black object (no obstacle) the IR rays are absorbed by the surface and cannot be captured. The sclera is white and thus acts as an obstacle while the iris acts as the reflecting object. It has been found that the average size of the iris is 11.8 mm with the majority of population falling between 10.2 mm and 13.0 mm. The average axial length along the visual axis is 24 mm. It was found that the accurate detection of the eyeball movements can be achieved by using three proximity IR sensor modules. A user has to look extreme left and extreme right to enable the wheelchair motion in either direction. When the gaze of the user is straight, the motion of the wheelchair is forward. Closing of the eyelids for a span of three seconds has been used to initiate and stop motion alternately. By using a timer delay of 3 seconds it has been ensured that the normal blinking of a user (12-13 times in a minute) doesn't interfere with the working of the program as the average blink time is 0.3 to 0.4 seconds. The signals after being received by the IR sensors are then fed to the PIC micro-controller. PIC microcontroller is preferred because the presence of an inbuilt ADC circuit in the IC makes the circuit simpler. Another reason for using PIC 18FXXX series is their MMC (Multi Media Card) support offered. The use of a MMC is helpful in creating a database for the patients that can be used further for studies and better calibrations. This device is extremely cost-effective as well as efficient.

### A. PIC Microcontroller

10 MIPS (100 nanosecond instruction execution) and CMOS FLASH-based 8-bit micro-controller packs Microchip's powerful PIC architecture into a 40 package. The PIC18F452 features a 'C' compiler friendly development environment, 256 bytes of EEPROM, Self-programming, an ICD, 2 capture/compare/PWM functions and 8 channels of 10-bit Analog-to-Digital (A/D) converter. The synchronous serial port can be configured as either 3-wire Serial Peripheral Interface (SPI™) or the 2-wire Inter-Integrated Circuit (I<sup>2</sup>C™) bus and Addressable Universal Asynchronous Receiver Transmitter (AUSART).

**B. ADC Module**

Built-in ADC (10 bit) of PIC is used for a precise estimation of an analog signal into a digital signal readily operational by the software burned into PIC.

**C. L293D IC**

Since motors require more current than the micro-controller pin can generate, we use motor drivers as current amplifiers. L293D is a 16 pin micro-controller which allows DC motors to rotate in either direction. The maximum voltage supply is 36 volts.

The raw signals are picked by three IR sensor modules, S1, S2 and S3, connected to the eyepiece, shown in Fig. 2. These signals are amplified and then sent to the ADC channels of PIC where they get converted to digital form (Fig. 3).

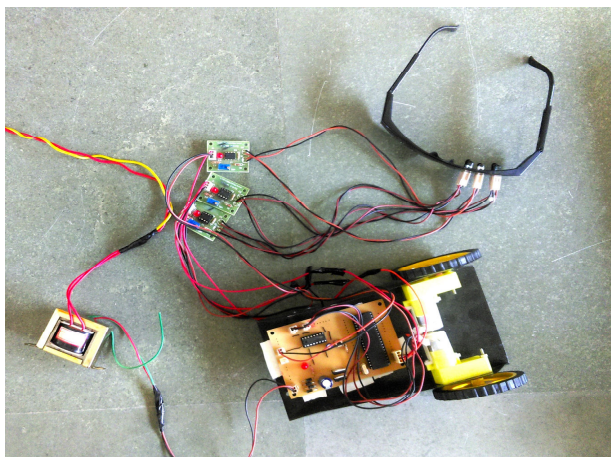

Fig. 2 Actual Photograph of Proposed Model

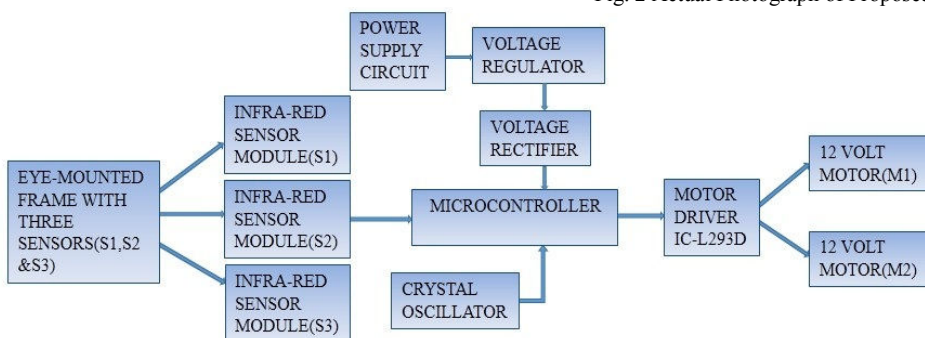

Fig. 3 Block Diagram of Proposed Model

TABLE I  
COMPILATION OF TRIALS AND ERRORS

S.NO.	Total no. of detections	Total no. of accurate left detections (S1)	Total no. of accurate center detections (S2)	Total no. of accurate right detections (S3)	Total no. of accurate detections	Accuracy	Error
P1	60	19/20	20/20	19/20	58	96.28%	3.32%
P2	60	19/20	20/20	20/20	58	96.28%	3.32%
P3	60	19/20	20/20	18/20	57	94.62%	4.98%
P4	60	18/20	20/20	19/20	57	94.62%	4.98%
P5	60	20/20	20/20	18/20	59	97.94%	1.66%
P6	60	20/20	20/20	19/20	59	97.94%	1.66%
P7	60	18/20	20/20	19/20	57	94.62%	4.98%
P8	60	18/20	20/20	20/20	58	96.28%	3.32%
P9	60	18/20	20/20	19/20	56	93.33%	6.66%
P10	60	19/20	20/20	19/20	58	96.28%	3.32%

When the gaze of the person is straight, sensor module S2 is focused on the iris and will produce the output 0 while the modules S1 and S3 give their outputs as 1. As long as the micro-controller receives this interrupt, the prototype moves forward. If S1, S2, S3 are producing the output 0, 1, 1 respectively, the user is looking extreme left and thus the wheelchair will turn left. This motion will continue till the arrival of the next interrupt, for instance the command to move right which is initiated if the user looks to extreme right (S1=1, S2=1, S3=0). The flowchart for the control scheme is shown in Fig. 4. These transmitted signals when receive by the PIC are used to activate the corresponding control algorithms.

**III. EXPERIMENTAL ANALYSIS**

To assess the sustainability of the proposed design, it was tested on 10 participants, where each person (P1, P2,...P10) was subjected to a total of 60 trial iterations. The trial was conducted to test three principal motions coordinated by corresponding eye movements. The total number of successful detections out of the net trials conducted (20 trials per eye motion) was logged with their respective accuracy and error percentages as shown in Table I.

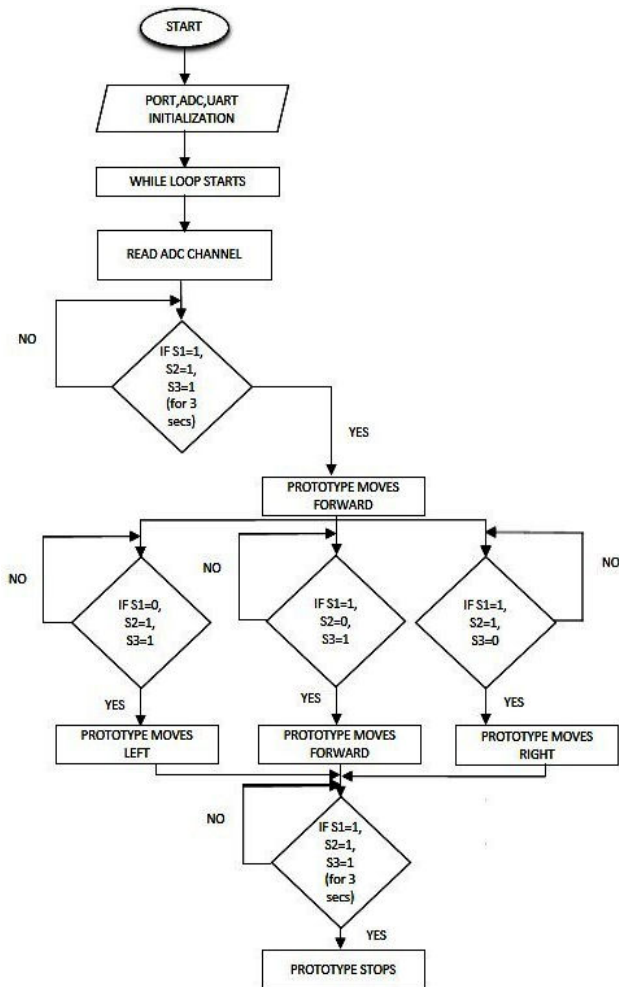

Fig. 4 Flowchart of proposed model

#### IV. RESULT

PIC 18FXXX series has been successfully used to design and test the eyeball motion controlled wheelchair using IR sensor modules. The outcomes of the variously conducted trials on different persons have been observed and logged to be used in case of future studies. The circuits and control algorithms have been successfully tested using Proteus Professional software. The proposed design is complete and successfully tested.

#### V. CONCLUSION AND FUTURE SCOPE

The IR sensor based eye-motion tracking system can be used as basic infrastructure in future technologies such as home automation. The system can be used for wireless automation by using radio frequency modification in the circuitry. This interface can be used to include an explicit input from the user by detecting intentional blinks and eye motions to create unique signatures. These signatures can then be used to generate control functions for individual home appliances. With various modifications, the proposed method can also be successfully implemented in vehicle automation.

The steering can be controlled by the motion a person's eyeball. Thus, we have made a platform for demonstrating and testing eye based interfaces at a very low cost and high efficiency which can be used on a large scale in various fields.

#### REFERENCES

- [1] [censusindia.gov.in/census\\_and\\_you/disabled\\_population.aspx](http://censusindia.gov.in/census_and_you/disabled_population.aspx)
- [2] [www.prsindia.org/billtrack/the-right-of-persons-with-disabilities-bill-2014-3122/](http://www.prsindia.org/billtrack/the-right-of-persons-with-disabilities-bill-2014-3122/)
- [3] R. A. Cooper, M. L. Boninger, A. Kwarcia, and B. Ammer, Engineering in Medicine and Biology, 24th Annual Conference and the Annual Fall Meeting of the Biomedical Engineering Society EMBS/BMES Conference, 2002. Proceedings of the Second Joint (Volume: 3)/23-26 Oct. 2002.
- [4] R. Berjoøon, M. Mateos, A. L. Barriuso, I. Muriel and G. Villarrubia, "Alternative human-machine interface system for powered wheelchairs", IEEE 1st International Conference on Digital Object Identifier, Serious Games and Applications for Health (SeGAH), 2011.
- [5] Monika Jain and Hitesh Joshi, Tongue Operated Wheelchair for Physically Disabled People, International Journal of Latest Trends in Engineering and Technology (IJLTET).
- [6] Rafael Barea, Luciano Boquete, Manuel Mazo and Elena López, System for Assisted Mobility Using Eye Movements based on Electrooculography, IEEE Transactions on Neural Systems and Rehabilitation Engineering, Vol. 10, no. 4, December 2002.
- [7] S. H. Fairclough and K. Gilleade (eds.), Advances in Physiological Computing, 39 Human-Computer Interaction Series, DOI: 10.1007/978-1-4471-6392-3\_3, Ó Springer-Verlag, London, 2014.
- [8] Jobby K. Chacko, Deepu Oommen, Kevin K. Mathew, Noble Sunny and N. Babu, Microcontroller Based EOG Guided Wheelchair, World Academy of Science, Engineering and Technology (WASET) International Journal of Medical, Health, Biomedical and Pharmaceutical Engineering, Vol. 7, No. 11, 2013.
- [9] Hansen DW and Ji Q, In the eye of the beholder: a survey of models for eyes and gaze, IEEE Trans Pattern Anal Mach Intell 32(3):478-500, 2009.
- [10] Ding Q, Tong K and Li G, Development of an EOG (ElectroOculography) based human-computer interface, In Proceedings of the 27th Annual International Conference of the Engineering in Medicine and Biology Society, pp 6829-6831, EMBS, 2005.
- [11] Kohei Arai and Ronny Mardiyanto, Eyes Based Electric Wheel Chair Control System, International Journal of Advanced Computer Science and Applications (IJACSA), Vol. 2, No. 12, 2011.
- [12] Poonam S. Gajwani & Sharda A. Chhabria, Eye Motion Tracking for Wheelchair Control, International Journal of Information Technology and Knowledge Management, Volume 2, No. 2, pp. 185-187, July-December 2010.
- [13] M. Reitbauer, Keep an Eye on Information Processing: Eye Tracking Evidence for the Influence of Hypertext Structures on Navigational Behaviour and Textual Complexity, LSP and Professional Communication, Vol. 8, No. 2 (16), Winter 2008.
- [14] DW Hansen and P Majaranta, Basics of camera-based gaze tracking, In: Majaranta P et al (eds) Gaze interaction and applications of eye tracking: advances in assistive technologies, Medical Information Science Reference, Hershey, pp 21-26, 2012.
- [15] J.Millanetal, "Noninvasive brain-actuated control of a mobile robot by human EEG," IEEE Trans. Biomed. Eng., vol. 51, no. 6, pp. 1026-1033, June 2004.
- [16] Kazuo Tanaka, Kazuyuki Matsunaga, and Hua O. Wang, Electroencephalogram-Based Control of an Electric Wheelchair, IEEE Transactions on Robotics, Vol. 21, no. 4, August 2005.
- [17] Gunda Gautam, Gunda Sumanth, Karthikeyan K C, Shyam Sundar and D. Venkataraman Eye, Movement Based Electronic Wheel Chair for Physically Challenged Persons, International Journal of Scientific & Technology Research, volume 3, issue 2, February 2014.