

Electric Field Impact on the Biomass Gasification and Combustion Dynamics

M. Zake, I. Barmina, A. Kolmickovs, R. Valdmanis

Abstract—Experimental investigations of the DC electric field effect on thermal decomposition of biomass, formation of the axial flow of volatiles (CO , H_2 , C_xH_y), mixing of volatiles with swirling airflow at low swirl intensity ($S \approx 0.2-0.35$), their ignition and on formation of combustion dynamics are carried out with the aim to understand the mechanism of electric field influence on biomass gasification, combustion of volatiles and heat energy production. The DC electric field effect on combustion dynamics was studied by varying the positive bias voltage of the central electrode from 0.6 kV to 3 kV, whereas the ion current was limited to 2 mA. The results of experimental investigations confirm the field-enhanced biomass gasification with enhanced release of volatiles and the development of endothermic processes at the primary stage of thermochemical conversion of biomass determining the field-enhanced heat energy consumption with the correlating decrease of the flame temperature and heat energy production at this stage of flame formation. Further, the field-enhanced radial expansion of the flame reaction zone correlates with a more complete combustion of volatiles increasing the combustion efficiency by 3% and decreasing the mass fraction of CO , H_2 and C_xH_y in the products, whereas by 10% increases the average volume fraction of CO_2 and the heat energy production downstream the combustor increases by 5-10%

Keywords—Biomass, combustion, electrodynamic control, gasification.

I. INTRODUCTION

HIGHLY intensive use of the fossil fuels (natural gas, coal, petroleum) for heat and energy production leads to a gradual increase of the carbon-dioxide concentration in the Earth's atmosphere and to global warming as well as to the depletion of fossil fuels reserves in the proximate future [1], [2]. Energy production from renewable fuels (wood, waste biomass, agricultural residues, etc.) has minimum impact on the environment and global warming, because the biomass burning produces carbon-neutral emissions and can substitute part of fossil fuel as an energy source [3]. Therefore, a clean and efficient energy production with a partial substitution of fuels by renewable energy resources is the driving force for further development of the energy production technologies. However, renewable fuels have lower heating values compared to fossil fuel, dissimilar structure and wide-range variations of the moisture content and chemical composition that can cause variations of the combustion characteristics with significant problems in boiler operation, which needs to

be improved. One of the possibilities to improve the combustion characteristics at thermochemical conversion of biomass is co-firing of wood biomass with a small amount of gas [4], [5]. Another way is thermal preprocessing of biomass by a high-frequency electromagnetic field of 9 GHz [6], [7]. This method can provide uniform spatial heating of biomass with a faster thermal destruction of hemicelluloses and cellulose determining a faster thermochemical conversion of the pre-treated biomass. An alternative biomass combustion control technique is based on the electric field-induced "ion-wind effect" determining the formation of interrelated processes of heat/mass transfer in the electric field direction with local variations of the combustion characteristics and produced heat energy [8]-[12]. Previous experimental studies of the DC electric field effect on the swirling flame formation and combustion of volatiles at high swirl intensity have shown that for such type of flames the field-enhanced mass transfer of the flame species in the field direction allows to control the process of products recirculation, with direct impact on the flame shape and combustion characteristics [10], [11].

These investigations are focused on improvement and control of the combustion characteristics at thermochemical conversion of biomass (wood pellets) using DC electric field effects on the biomass gasification and combustion of volatiles at low swirl intensity with the aim to increase the total amount of produced heat energy and minimize the environmental impact of combustion systems.

II. EXPERIMENTAL

The DC electric field effect on the thermochemical conversion of wood biomass, formation of combustion dynamics and on the composition of the products is studied experimentally using a batch-size experimental device along with integrated processes of biomass gasification and combustion of volatiles at an average heat power up to 2 kWh. The main components of the experimental device are a biomass gasifier (1), water-cooled sections of the combustor of inner diameter $D = 60$ mm (2), a swirling propane/air burner (3), inlet ports of primary (4) and secondary swirling air supply (5), and diagnostic sections (6) with peepholes for local placing of diagnostic tools (thermocouples, gas sampling probes) into the flame (Fig. 1). Discrete doses of wood pellets ($m = 240$ g) are added into the gasifier up to the inlet port of the propane flame flow, which is used to initiate thermal decomposition of biomass (wood) pellets and ignition of volatiles. The duration of the heat input by the propane flame flow into the biomass was limited to 350 s and it was switched out when the self-sustaining processes of biomass gasification

M. Zake is with the Institute of Physics, University of Latvia, 32 Miera street, LV-2169, Salaspils, Latvia (corresponding author to provide phone: +371 29891137; fax: +371 67901214; e-mail: mzf@sal.lv).

I. Barmina, A. Kolmickovs, and R. Valdmanis are with the Institute of Physics, University of Latvia, 32 Miera street, LV-2169, Salaspils, Latvia (e-mail: barmina@sal.lv, antons.kolmickovs@gmail.com, rww@inbox.lv).

and combustion of volatiles were developing. The primary and secondary swirling airflow was supplied with the average rates 22 l/min and 40 l/min. The primary air supply was used to initiate biomass gasification, which develops under fuel-rich conditions ($\alpha \approx 0.3-0.4$). The secondary air supply was used to provide mixing of the combustible volatiles with the air and their complete burnout downstream the combustor at an average air excess in the flame reaction zone of $\alpha \approx 1.2-2$.

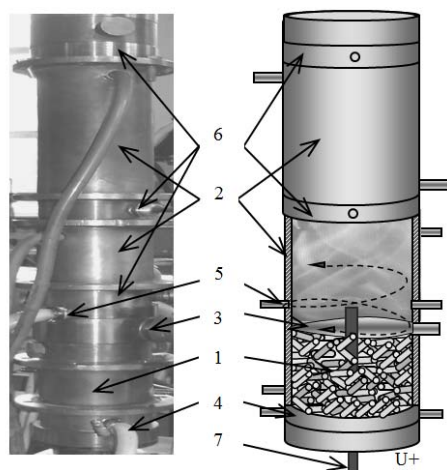

Fig. 1 Digital image and principal schematic of the small-scale pilot device

Electrical control of wood biomass gasification and combustion of volatiles was provided using a single electrode configuration when an electrode was axially inserted through the biomass layer towards the combustor bottom. An electric field was applied between the positively biased electrode (7) and the grounded channel walls. The voltage of the axially inserted electrode relative to the channel walls could be varied from 0.6 kV up to 3 kV, whereas the ion current in these experiments was limited to 2 mA.

The experimental study involves complex measurements of the biomass weight loss rate (dL/dt) by using a moving rod supplied with a pointer, spectral measurements of the gasification products (C_2H_2 , C_2H_4 , CH_4 , CO) composition by a FTIR spectrometer, and on-line with a time interval of 1 sec measurements of the swirling flame velocity, temperature and composition (CO , H_2 , CO_2 , NO_x) profiles at the combustion of volatiles using gas analyzers Testo 435 and Testo 350 XL. Calorimetric measurements of the cooling water flow in the water-cooled combustor were made to estimate the effect of biomass characteristics variations on the heat production rates during the combustion of the volatiles. The measurements of the temperature and heat production rates were recorded using a data plate PC-20 TR.

III. RESULTS AND DISCUSSION

A. Development of Combustion Dynamics at Thermochemical Conversion of Biomass Pellets

The process of biomass thermochemical conversion

develops with the subsequent stages of endothermic processes of biomass heating, drying, thermal decomposition and of exothermic processes of volatiles and char combustion.

The primary processes of biomass heating and drying take place in the temperature range $T = 300-420$ K and last up to 400 s. The biomass heating and drying result in a release of moisture and light volatiles along with the variations of the peak values of biomass weight loss from $dm/dt = 0.1$ g/s to 0.3 g/s (Figs. 2 (a) and (b)).

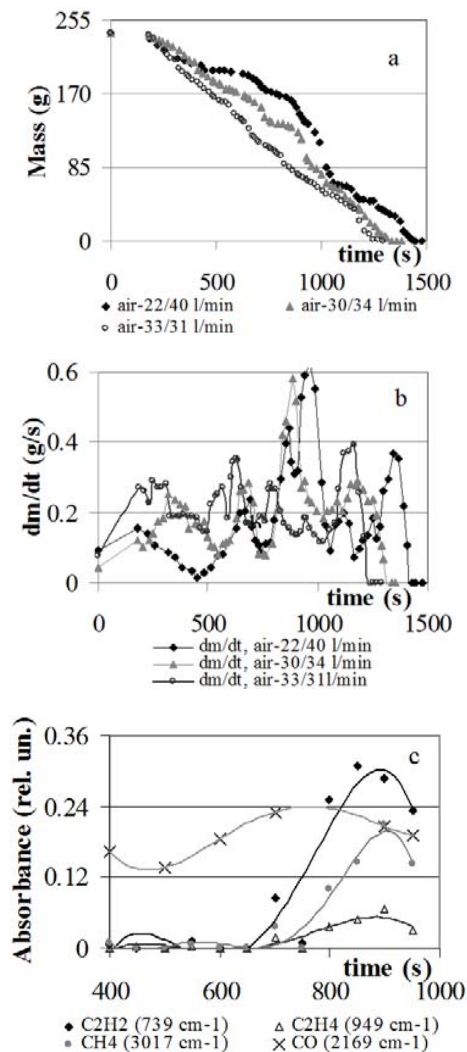

Fig. 2 Effect of different air supply on the variations of wood pellet mass loss (a) and weight loss (b) rates; time-dependent variations of the absorption intensity of the main products (c)

The next stage of biomass weight loss at $t > 400$ s is the thermal decomposition of the main biomass constituents – hemicellulose, cellulose and lignin at temperatures of 490-600 K, 580-650 K, and 520-800 K, respectively [12]. The biomass thermal decomposition at this stage results in an increase of the peak values of biomass weight loss up to 0.6 g/s at $t \approx 800-1000$ s (Fig. 2 (b)) with the correlating increase of infrared absorbance of the main combustible gas-phase species (C_2H_2 ,

C_2H_4 , CH_4 , CO , etc.) (Fig. 2 (c)). The biomass weight loss rate at the biomass thermal decomposition with a high accuracy ($R^2 = 0.97-0.99$) can be presented as a linear dependence on the primary air supply rate, which is responsible for the development of the biomass gasification processes and for the formation of the axial flow of volatiles above the biomass layer at the thermal decomposition of hemicellulose, cellulose and lignin.

The flame reaction zone is formed at swirl-enhanced mixing of the axial flow of volatiles with the swirling airflow, which leads to the ignition and combustion of the volatiles. The modeling experiments have shown [13] that a typical feature of the swirling flame formation for the given configuration of the experimental device is the formation of downstream and upstream swirling airflows above and below the swirling air nozzles. With a low swirl intensity ($S < 0.6$), the upstream swirl flow formation is responsible for primary swirl-enhanced mixing of the axial flow of volatiles with an air swirl just above the biomass layer and for the development of flame velocity profiles. At the primary stage of flame formation ($L/D < 1$) the upstream air swirl slows down the axial flow of volatiles close to the channel walls ($r/R > 0.8$), where the tangential velocity of the downstream and upstream swirling air flows increases to the peak values (Fig. 3).

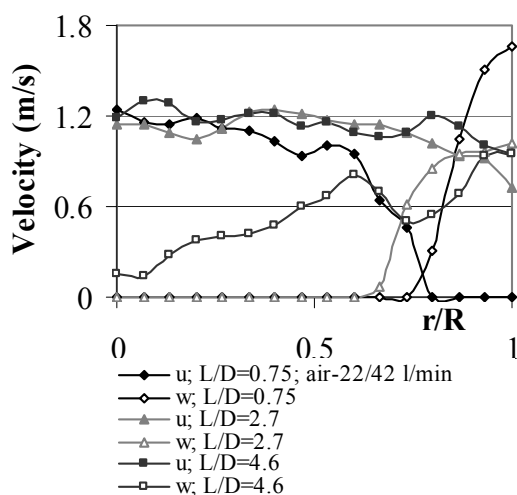

Fig. 3 The formation of flame velocity profiles downstream the combustor with a low swirl number of the inlet flow ($S = 0.25$)

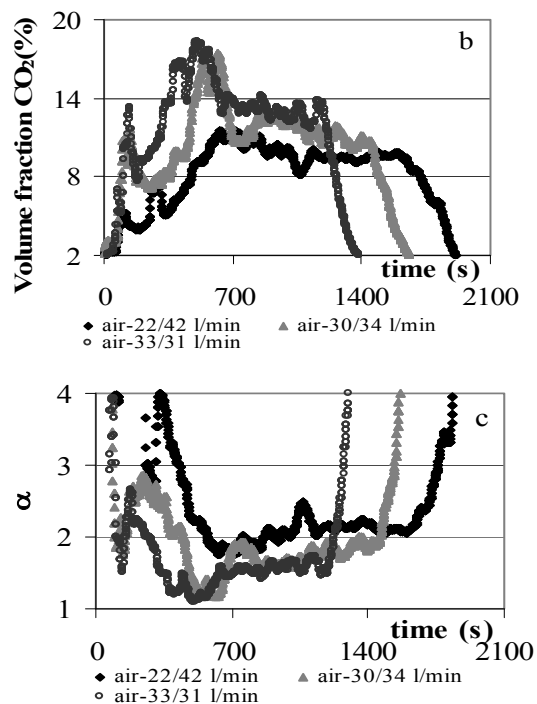
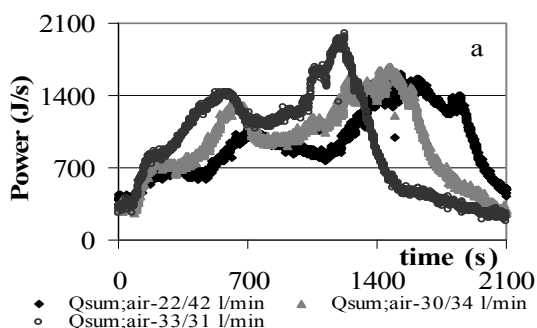

Fig. 4 Time-dependent variations of the heat power (a) CO_2 volume fraction (b) and excess air ratio in the flame reaction zone (c) at thermochemical conversion of wood pellets

In contrast, the axial flame velocity increases towards the centerline of the combustor ($r/R < 0.5$), where the tangential flow velocity decreases to a minimum value with evident spatial separation of the downstream axial and tangential flows (Fig. 3). Hence, at the primary stage of the flame reaction zone formation ($L/D > 0.75$) the mixing of the axial flow of volatiles with the downstream swirling air flow is incomplete that is confirmed by FTIR measurements of the flame composition, indicating a high level of unburned hydrocarbons (Fig. 2) in the flame reaction zone. The further development of the downstream flow ($L/D > 1$) reveals the radial expansion of the flame reaction zone with the correlating expansion of the axial velocity profiles, which occurs due to swirl-enhanced mixing of the axial flow of volatiles with the downstream swirling airflow (Fig. 3).

The development of the flame reaction zone at biomass thermochemical conversion results in time-dependent variations of the produced heat power and CO_2 volume fraction in the products (Figs. 4 (a) and (b)) with correlating variations of the air excess ratio (α) in the flame reaction zone (Fig. 4 (c)).

As seen from Fig. 4, the highest values of the air excess ratio in the flame reaction zone are observed at the primary stage of the thermochemical conversion of wood pellets ($t < 400$ s) and rapidly decreases after the ignition of volatiles with the correlating increase of the produced heat power and CO_2 volume fraction. By analogy with the velocity profiles formation the peak values of the flame temperature and CO_2 volume fraction were found close to the flame axis ($R = 0$).

B. Electric Field Effect on Thermo Chemical Conversion of Biomass

When a DC electric field is applied to the flame, the increase of the average biomass weight loss from 0.14 g/s to 0.18 g/s evidences that the electric field induced current in the space between the electrodes enhances the thermal decomposition of biomass pellets (Fig. 5).

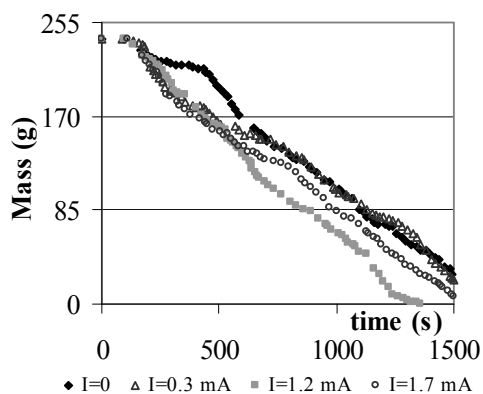

Fig. 5 The electric field-induced current effect on the time-dependent variations of the biomass weight loss

FTIR measurements and analysis of the gas-phase composition at the bottom of the combustor ($L/D = 0.75$) confirm the field-enhanced thermal destruction of the main biomass constituents - hemicellulose, cellulose and lignin resulting in an enhanced release of the main combustible species (CO , CH_4 , C_2H_2 , C_2H_4 , etc.) and CO_2 (Fig. 6). As follows from Fig. 6, during the first stage of biomass (wood pellets) thermal decomposition ($t < 500$ s), when the processes of hemicellulose depolymerization and decarboxylation are initiated, the field-enhanced release of CO dominates. The absorbance of CO acquires its peak value at $t = 500$ s and starts to decrease at $t > 700$ s. The next stage of the field-enhanced thermal decomposition of wood pellets ($t > 600$ s) can be related to cellulose depolymerization and dehydration of hemicellulose monomers, oxidation, decarboxylation and cycle opening, when other volatiles like CH_4 , C_2H_2 and C_2H_4 are found in the gaseous products.

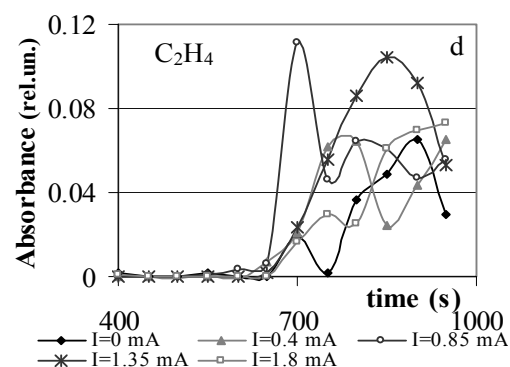
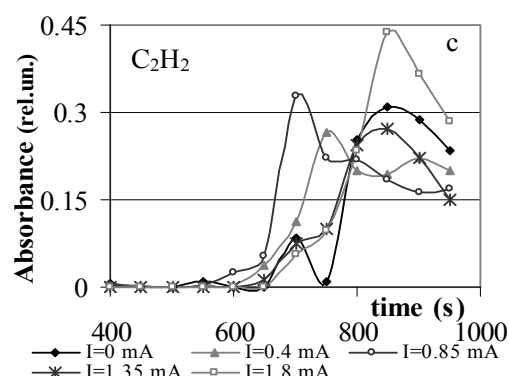
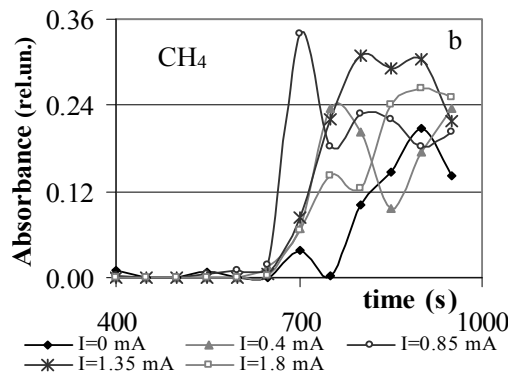
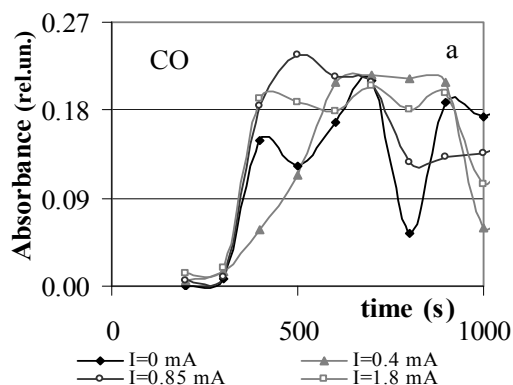

Fig. 6 Time-dependent variations of the combustible volatiles absorbance at field-enhanced thermal decomposition of biomass pellets

In addition to the field-induced variations of the biomass thermal decomposition, the field-induced variations of the flame dynamics were observed (Fig. 7).

As seen from Fig. 7, the dominant electric field-induced variations of the flame dynamics downstream the combustor are observed along the outside part of the flame reaction zone close to the channel walls, with the correlating field-induced decrease of the axial and tangential velocity components (Fig. 7). This correlation allows to suggest the field-enhanced formation of the upstream swirling air flow by limiting the formation of the axial flow of volatiles, with a faster decrease of the downstream swirling air flow close to the channel walls and towards the flame centerline. The field-enhanced formation of the upstream air swirl motion is confirmed by

measuring the average values of the axial and tangential velocity components below the swirling air nozzles so proving the decrease of the axial flow velocity average value, whereas the average value of the upstream swirling air velocity increases, with the peak value of the field-induced current increase by 1-1.2 mA and positive bias voltage of the axially inserted electrode by 1.5-1.8 kV.

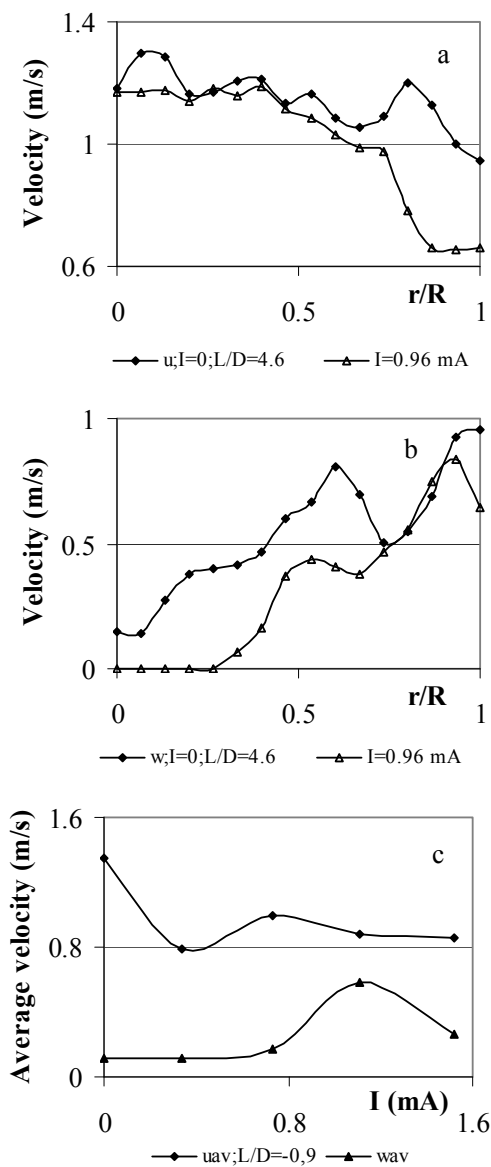

Fig. 7 Field-induced variations of the axial (a) and tangential (b) velocity profiles above (a, b) and below (c) the swirling air nozzles

The field-enhanced thermal decomposition of biomass pellets and the field-enhanced upstream swirl motion determining the swirl-enhanced mixing of the axial flow of volatiles with the air result in field-induced variations of the combustion dynamics providing a variation of the produced heat energy and heat release rate at the thermochemical

conversion of wood pellets (Fig. 8).

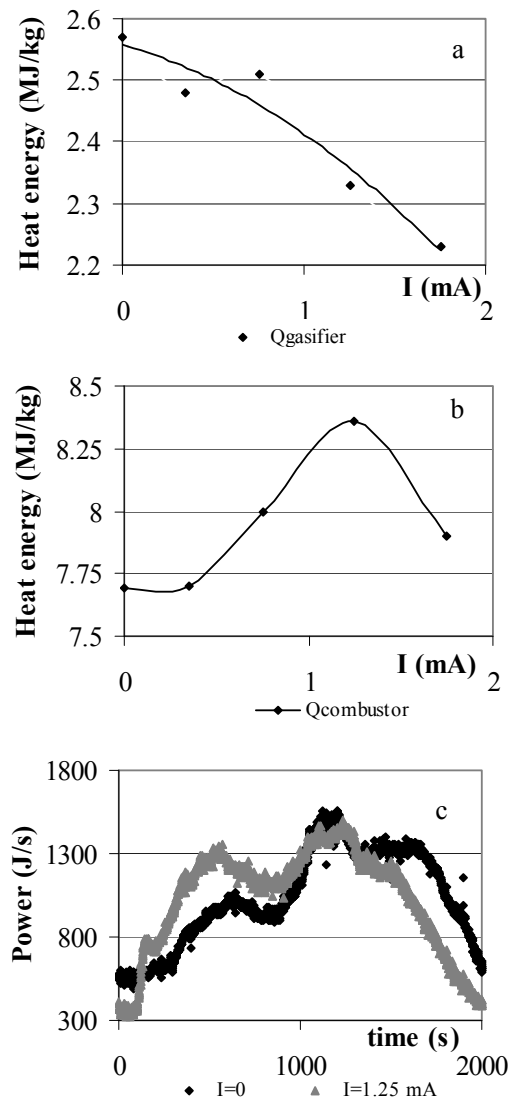

Fig. 8 Electric field-induced variations of the produced heat energy at biomass gasification (a) and combustion of volatiles (b); and heat power time-dependent variations (c)

The development of the endothermic processes of field-enhanced thermal degradation of wood pellets (Fig. 5) results in an intensive heat energy consumption at the biomass gasification stage, thus decreasing by about 13 % the produced heat energy at this stage of thermochemical conversion of biomass pellets (Fig. 8 (a)). In contrast, the field-enhanced mixing of the axial flow of volatiles with the upstream air swirl assures the field-enhanced ignition and combustion of volatiles downstream the combustor, so increasing the produced heat energy by about 11 %. In fact, the peak value of the produced heat energy (Fig. 8 (b)) correlates with the peak value of the upstream field-enhanced air swirl motion (Fig. 7 (c)), which leads to swirl-enhanced mixing of the flame components and to faster burnout of volatiles, as confirmed by

the measurements of the biomass weight loss (Fig. 5), determining the faster heat power release at thermochemical conversion of biomass pellets (Fig. 8 (c)). The local measurements of the flame temperature have shown that the produced heat energy field-enhanced increase correlates with the decrease of the temperature average value near the flame axis by about 11 %. This correlation confirms that the mechanism, which is responsible for the field-enhanced increase of the produced heat energy, can be related to the field-induced ion wind motion [8] determining the formation of the interrelated processes of field-enhanced heat/mass transfer in the field direction. Regarding [14], this leads to field-enhanced flame homogenization, which decreases the peak flame temperature with the correlating increase of the produced heat energy.

With the air excess supply into the flame reaction zone ($\alpha \approx 1.2-1.4$), the biomass field-enhanced thermochemical conversion with the enhanced release and combustion of volatiles correlates with the field-enhanced variation of the product composition and combustion efficiency (Fig. 9). The local measurements of the flame composition confirm the field-enhanced combustion of volatiles, which leads to increasing the average CO_2 volume fraction in the products by 10% and combustion efficiency by 3 %, whereas the excess air ratio in the products decreases by about 10 %, which is the evidence of a more complete combustion of volatiles (Fig. 9). Moreover, the field-enhanced decrease of the peak temperature of the flame reaction zone limits the temperature-sensitive NO_x formation, which, in accordance with the two-step Zeldovich mechanism, exponentially increases with an increase of the flame temperature [15]. Hence, the peak flame temperature decrease with the homogenization of the flame reaction zone results in a decrease of the average value of the NO_x emission mass fraction in the products by about 12 %. Finally, the presented results allow to conclude that the field-induced variations of the combustion dynamics at the thermochemical conversions of biomass pellets determine a cleaner and more effective heat energy production.

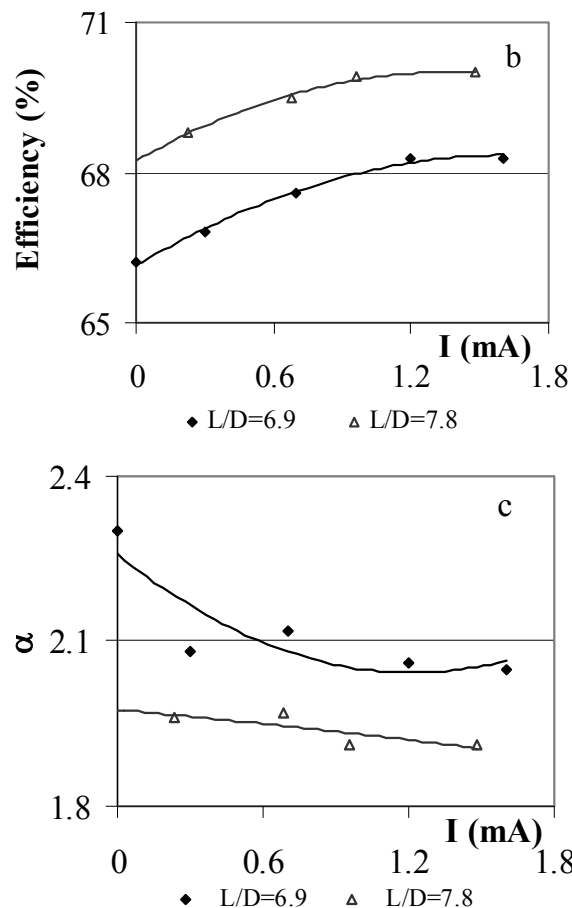
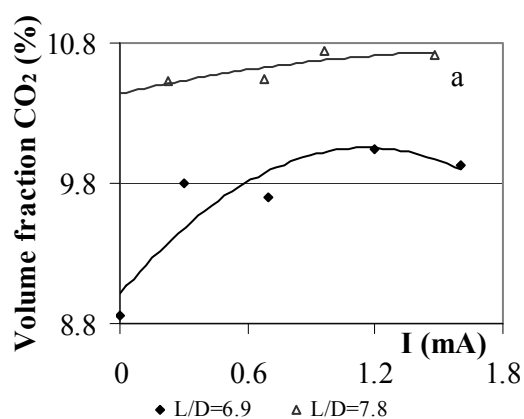

Fig. 9 The DC electric field effect on the volume fraction of CO_2 (a), on the combustion efficiency (b) and air excess ratio (c) in the products at different stages of swirling flame formation

IV. CONCLUSIONS

The performed experimental study of the electric field effect on the thermochemical conversion of biomass (wood pellets) leads to the following conclusions:

The primary electric field effect on the thermo-chemical conversion of biomass can be related to the biomass field-enhanced thermal decomposition promoting the enhanced release of combustible volatiles.

The field-enhanced upstream airflow formation ensures the enhanced mixing of the upstream air swirling flow with the axial flow of volatiles so determining a faster ignition and a more complete combustion of volatiles downstream the combustor and increasing the produced heat energy at the thermo-chemical conversion of biomass pellets.

The field-enhanced variation of the products composition and combustion efficiency confirm that the electric field effect on the flame can be used to obtain a cleaner and more effective heat energy production.

ACKNOWLEDGMENT

The authors would like to acknowledge the financial

support from the Latvian research grant No. 623/1.

REFERENCES

- [1] L. David Roper. Future World Energy, 2015. <http://www.roperld.com/science/energyfuture.htm>
- [2] J. Capellan-Perez, M. Mediavilla, C. de Castro, O. Carpintero, L.J. Miguel. Fossil fuel depletion and socio-economic scenarios: an integrated approach, Energy, 2014, vol. 77, pp. 641-666.
- [3] Roger A. Sedjo. Comparative life cycle assessments: carbon neutrality and wood biomass energy, Resources for the Future DP13-11, Washington, 2013, pp. 1-21, <http://www.rff.org/RFF/Documents/RFF-DP-13-11.pdf>
- [4] M. Zaķe, I. Barmina, V. Krishko, M. Gedrovics, A. Desņickis. Experimental Study of the Combustion Dynamics of Renewable & Fossil Fuel Co-Fire in Swirling Flame. Latvian Journal of Physics and Technical Science, Nr. 6, 2009, pp. 3-15. <http://www.degruyter.com/view/j/lpts.2009.46.issue-6/v10047-009-0024-z/v10047-009-0024-z.xml>
- [5] Gray Davis, Biomass Co-firing with Natural Gas in California, report P500-02-050F, 2002, pp.36: http://www.energy.ca.gov/reports/2002-11-12_500-02-050F.PDF
- [6] Barmina I., Lickrastina A., Purmalis M., Zake M., Valdmanis R., Valdmanis J., Effect of biomass high-frequency pre-treatment on combustion characteristics// Chemical Engineering Transactions, vol.29, 2012, pp. 895-900.
- [7] B. Lanigan, V. Budarin, J. Clark, P. Shuttleworth, F. Deswarte, A. Wilson. Microwave processing as a green and energy efficient technology of energy and chemicals from biomass and energy crops. Aspects of Applied Biology, vol. 90 (2008), pp. 277-282.
- [8] J. Lawton and F. Weinberg, Electrical Aspects of Combustion, Clarendon Press, Oxford, UK, 1969.
- [9] Jagers H.C., Von Engel A., 1971, The Effect of Electric Fields on the Burning Velocity of Various Flames. In: Combustion and Flame, vol. 16, 275-285.
- [10] M. Zake, I. Barmina, A. Meijere, Electric Control of Combustion and Formation of Polluting Emissions by Co-Firing the Renewable with Fossil Fuel, Magentohydrodynamics, 2005, N3, pp. 255-271.
- [11] I. Barmina, A. Desņickis, M. Zake, The Influence of the Electric Field on the Development of the Swirling Flame Velocity Field and Combustion Characteristics, Journal of Heat Transfer Research, vol. 39, N 5, 2008, begell housepublishers, pp.371-378.
- [12] I. Barmina, M. Zaķe, R. Valdmanis, Electric Field-Induced Variations of Combustion Dynamics, Chemical Engineering Transactions, 2014, vol. 39, pp.1531-1536.
- [13] M.Abricka, I. Barmina, R. Valdmanis, M. Zaķe, Experimental and numerical study of swirling flows and flame dynamics, Latvian Journal of Physics and Technical Sciences, 2014, vol. 4, 25-41.
- [14] J. Colannino (2012), Electrodynamic Combustion Control™ Technology, A Clear Sign White Paper, pp. 1-11, ClearSign Combustion Corporation, Seattle, www.clearsigncombustion.com
- [15] M. Zake, D. Turlajs, M. Purmals. Electric field control of NO_x formation in the flame channel flows, Global Nest: the International Journal, vol. 2, N1, 99-109.