

Experimental Implementation of Model Predictive Control for Permanent Magnet Synchronous Motor

Abdelsalam A. Ahmed

Abstract—Fast speed drives for Permanent Magnet Synchronous Motor (PMSM) is a crucial performance for the electric traction systems. In this paper, PMSM is derived with a Model-based Predictive Control (MPC) technique. Fast speed tracking is achieved through optimization of the DC source utilization using MPC. The technique is based on predicting the optimum voltage vector applied to the driver. Control technique is investigated by comparing to the cascaded PI control based on Space Vector Pulse Width Modulation (SVPWM). MPC and SVPWM-based FOC are implemented with the TMS320F2812 DSP and its power driver circuits. The designed MPC for a PMSM drive is experimentally validated on a laboratory test bench. The performances are compared with those obtained by a conventional PI-based system in order to highlight the improvements, especially regarding speed tracking response.

Keywords—Permanent magnet synchronous motor, model predictive control, optimization of DC source utilization, cascaded PI control, space vector pulse width modulation, TMS320F2812 DSP.

I. INTRODUCTION

IN Electric and Hybrid Electric Vehicles (EV/HEV) applications, fast speed tracking with current and voltage boundaries are required from the powertrain drives. The Field Oriented Control (FOC) with SPWM and SVPWM modulators with cascaded PI controllers are having many constraints for producing fast and smooth speed performances over large speed operating range. The solution proposed here is the MPC. Several predictive control techniques have been proposed in the literature for power electronics and electrical drives, which are well summarized and classified in [1]-[6]. MPC is the only one among the so-called advanced control techniques which has been extremely successful in practical applications in recent decades, exerting a great influence on research [1]. In the field of power electronics and drives, MPC has by now become an established control technique [2]. Several predictive control techniques have been proposed in the literature for power electronics and electrical drives, which are well summarized and classified as in [3]. A comparative assessment of SVPWM and MPC for VSI in terms of THD is presented in [4]. MPC was found superior in terms of THD. Model predictive control strategies like SVPWM take advantage of the fact that only a finite number of possible switching states are associated with VSI. DSP-Based permanent magnet synchronous motor drives for EV/HEV applications has been implemented by the author in [7].

With the rapid development in microprocessors, the high

performance TMS320F28x Digital Signal Processor (DSP) chip becomes a popular research on digital control [8], [9]. The DSP is used for ac drives due to their high-speed performance, simple circuitry, and on-chip peripherals of a micro-controller into a single chip solution. Therefore, in this paper, a TMS320F2812 DSP embedded with the software of current vector control, Space Vector Pulse Width Modulation (SVPWM) scheme. PI controllers, and model predictive control strategy have been developed for a high performance speed control for PMSM drives. With the excellent characteristics of the used DSP [10], it will make drives of PMSM more programmable, robust and easy implementation. Power electronics integration technologies have been used to build the driving circuits for the PMSM using the TMS320F2812 DSP as in [11]. System hardware design which includes DSP control circuits, power driver circuit, signals detection circuit and protection circuit have been introduced in [12]. Some application problems of PMSM vector control system have been discussed in [13]. Also, [14] proposed the main hardware structure part for the PMSM servo system.

In this paper, predictive current control (PCC) for a Permanent Magnet Synchronous Machine (PMSM) is developed. The proposed MPC technique is based on optimization of the voltage vector applied to the power converter. The choice of this vector depends on a proposed cost function. This object function guarantees the fast tracking for the torque-producing and torque-producing current components. The control technique is investigated by experimental implementation. This proposed method is compared with the widely used FOC.

II. DRIVE SYSTEM DESCRIPTION

The control scheme for FOC of the PMSM using predictive current control is shown in Fig. 1. Here, a PI controller is used for speed control and generates the reference for the torque-producing current i_{sq}^* . A predictive current controller is used for tracking this current. In the predictive scheme, the discrete-time model of the machine is used for predicting the stator current components for the seven different voltage vectors generated by the inverter. The voltage vector that minimizes a cost function is selected and applied during a whole sampling interval.

Abdelsalam A. Ahmed is with the Electrical Power Systems and Machines, Faculty of Engineering, Tanta University, Egypt (corresponding author to provide phone: +2-012-25589198; e-mail: dr.abdelsalamahmed@yahoo.com).

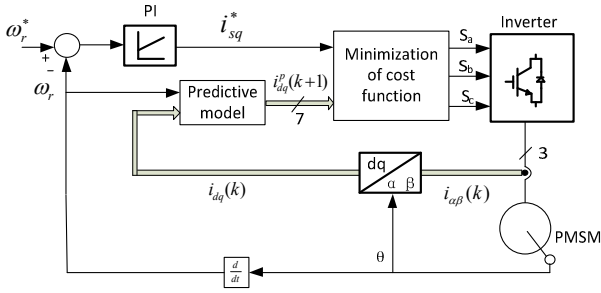

Fig. 1 PMSM drives using model predictive current control of PMSM

III. DESIGN AND IMPLEMENTATION OF MPC FOR THE PMSM

A. Motor Continuous State-Space Model and State Variables for MPC

The first step in the design of a MPC consists in determining a discrete-time model for the system. MPC can be best implemented for the class of systems that accepts a representation by a linear model with constraints, because, in that case, most of the optimization process can be moved offline. The linear model has to be pursued by an appropriate choice of the state variables. The state space representation for the PMSM can be summarized as $\frac{d}{dt}x(t) = g(x(t), u(t))$. Where the state vector $x = [i_d \ i_q \ \omega]^T$ and the input signal is the 2-D voltage vector $u = [u_d \ u_q]^T$. According to this choice, the continuous state-space model for the motor is then:

$$\frac{d}{dt} \begin{bmatrix} i_d(t) \\ i_q(t) \\ \omega(t) \end{bmatrix} = \begin{bmatrix} -\frac{R}{L_d} & \frac{L_q}{L_d} \omega(t) & 0 \\ -\frac{L_d}{L_q} \omega(t) & -\frac{R}{L_q} & -\frac{1}{L_q} \lambda_{PM} \\ 0 & \frac{1.5p^2}{J_{eq}} \lambda_{PM} & -\frac{B}{J_{eq}} \end{bmatrix} \begin{bmatrix} i_d(t) \\ i_q(t) \\ \omega(t) \end{bmatrix} + \begin{bmatrix} \frac{1}{L_d} & 0 & 0 \\ 0 & \frac{1}{L_q} & 0 \\ 0 & 0 & -\frac{p}{J_{eq}} \end{bmatrix} \begin{bmatrix} u_d(t) \\ u_q(t) \\ T_L(t) \end{bmatrix} \quad (1)$$

B. Motor Model Discretization

To predict the current at sampling time $(k+1)$ with the measured position, speed and currents at sampling time k , a discrete model of the motor and its drive are needed. Applying the forward Euler discretization theory at (1), the resulting discrete time model is given in form of

$$x(k+1) = Ax(k) + Bu(k)$$

as:

$$\begin{bmatrix} i_d(k+1) \\ i_q(k+1) \\ \omega(k+1) \end{bmatrix} = \begin{bmatrix} 1 - \frac{R}{L_d} T_s & \frac{L_q \omega(k)}{L_d} T_s & 0 \\ 0 & 1 - \frac{R}{L_q} T_s & -\frac{(\lambda_{PM})}{L_q} T_s \\ 0 & \frac{1.5p^2 \lambda_{PM}}{J_{eq}} T_s & 1 - \frac{B}{J_{eq}} T_s \end{bmatrix} \begin{bmatrix} i_d(k) \\ i_q(k) \\ \omega(k) \end{bmatrix} + \begin{bmatrix} \frac{1}{L_d} T_s & 0 & 0 \\ 0 & \frac{1}{L_q} T_s & 0 \\ 0 & 0 & -\frac{p}{J_{eq}} T_s \end{bmatrix} \begin{bmatrix} u_d(k) \\ u_q(k) \\ T_L(k) \end{bmatrix} \quad (2)$$

where, J_{eq} , ω_m , ω are equivalent inertia of motor and load, mechanical angular velocity, and electrical angular velocity respectively.

C. Inverter and Switching States

For 2-level three-phase inverter, the inverter switching voltages directly in the dq-reference frame can be derived as:

$$\begin{bmatrix} V_d \\ V_q \end{bmatrix} = \frac{2}{3} V_{DC} \begin{bmatrix} \cos(\theta) & \cos(\theta - \frac{2\pi}{3}) & \cos(\theta + \frac{2\pi}{3}) \\ -\sin(\theta) & -\sin(\theta - \frac{2\pi}{3}) & -\sin(\theta + \frac{2\pi}{3}) \end{bmatrix} \begin{bmatrix} S_a \\ S_b \\ S_c \end{bmatrix} \quad (3)$$

The vector s_{abc} is the switching function for the three phases with the value 1 when upper leg semiconductor is ON and 0 when it is OFF.

D. Optimization of the DC Voltage Utilization

The objectives of the predictive current control scheme are torque current reference tracking, torque by ampere optimization, and current magnitude limitation. These objectives can be expressed as the following cost function:

$$g = (i_d^p(k+1))^2 + (i_q^* - i_q^p(k+1))^2 + \hat{f}(i_d^p(k+1), i_q^p(k+1)) + \lambda_{sw} \cdot n \quad (4)$$

where, the first term represents the minimization of the reactive power, allowing the torque by ampere optimization. The second term is defined for tracking the torque-producing current, and the last term is a nonlinear function for limiting the amplitude of the stator currents. This term, i.e., \hat{f} , is a highly nonlinear function that takes into account restrictions on the maximum stator current, imposing hard constraints on the maximum values of the stator currents. This function is given by

$$\hat{f}(i_d^p, i_q^p) \triangleq \begin{cases} \infty & \text{if } |i_q^p| > \hat{i}_q \text{ or } |i_d^p| > \hat{i}_d \\ 0 & \text{if } |i_q^p| \leq \hat{i}_q \text{ and } |i_d^p| \leq \hat{i}_d \end{cases} \quad (5)$$

For all possible switching states for three phases, the voltage vectors components v_{dq}^p are predicted depending on the measured rotor position. Then, the values of stator current components i_{dq}^p are assigned according to the predicted voltage vectors, the measured stator currents i_{dq} , machine's parameters, and the used sampling time period T_s . The stator currents i_{dq} are hardly constrained for guaranteeing the overcurrent precautions at different speed levels. Also, the objective function is augmented by a term of $\lambda_{sw} \cdot n$ for minimizing the switching frequency of the power switches. Inverter dead-time is considered to prevent the short-circuit faults at commutation instants. The voltage drop due to the dead-time is compensated. The optimal value of the objective function is applied during the next sampling period. The objective function is evaluated for each of the eight possible voltage vectors in order to calculate the future optimal value of the load current.

IV. EXPERIMENTAL SET UP DRIVE SYSTEM

The overall experimental system is depicted in Fig. 2 which includes a TMS320F2812 DSP control board with its different peripherals, a voltage source IGBT-based IPM drives and measurement circuits, 3-ph PMSM with an incremental encoder that used as motor feedback, an electromagnetic brake device, single-phase adjustable output transformer, PC with

Code Composer Studio (CCS) installed. The experimental setup for real tests is depicted in Fig. 3. The specifications of the used PMSM are described in Table I. The specifications of the drive system are described in Table II.

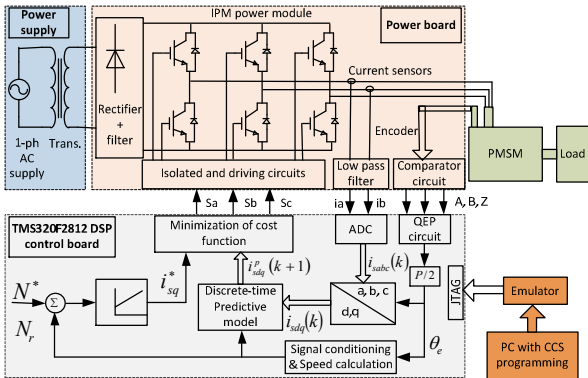

Fig. 2 Drive system based on model predictive control

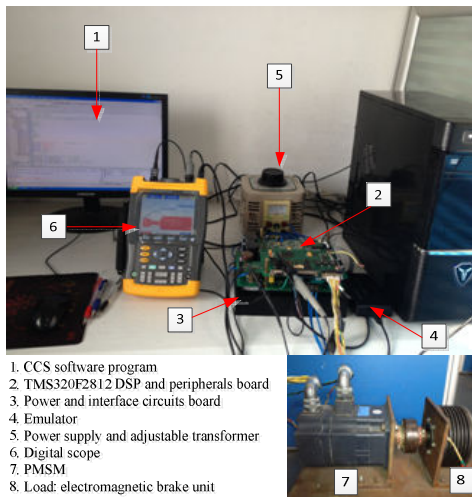

Fig. 3 Experimental setup for real tests

TABLE I
SPECIFICATIONS OF THE PMSM

Specification	Unit	Value
Rated/Max. speeds	rpm	2000/2500
Standstill torque,	Nm	3
Standstill current	A	2.5
Torque C. (KT)	Nm/A	1.2
Pole pairs		3
Voltage C. (Ke)	V/Krpm	80
Rotor moment of inertia	10-4 Kg.m ²	4.4
Friction coefficient	N.m.s/rad	0.00001
Stator resistance	Ω	3
Inductance	mH	11.5
Flux linkage	Web	0.178

An experimental setup was developed using a DSP model of TMS320F2812. An experimental study is carried out with the aim of corroborating the effectiveness of the proposed MPC in comparison with a FOC based on SVPWM

modulator. MPC and SVPWM control algorithms have been implemented with a sampling time of $T_s = 100 \mu s$ and the dead-time of $T_d = 3 \mu s$, and tested with a load of 3N.m. The DC link voltage is set to 140V. The speed performances are experimentally investigated for both techniques.

TABLE II
SPECIFICATIONS OF THE DRIVE SYSTEM

Device	Specification, Value (unit)
Load	Adjustable brake unit: 24 (V), 0.5 (A), 0~10 (Nm), 110 (W)
DSP	TMS320F2812: 150MHz, 32-bit fixed-point CPU, 12-bit ADC
Transformer	1kVA, 50Hz, 220V input voltage, 0~250V output voltage, 4 A rated current
Power board	IPM power module with six IGBT power transistors: PS21867-AP (600V, 30 A); Hall-based current sensors, 20 A.
Incremental encoder	2500 pulses/rev

V. SYSTEMS PERFORMANCE ASSESSMENT

Fig. 4 shows the speed performance when it is referenced at 0, 500, and 1000 RPM for SVPWM as in Fig. 4 (a) and for MPC as in Fig. 4 (b). It can be noticed that with MPC, the speed matches its reference very fast more than that of conventional control method. Fig. 5 shows the speed performance when it is reversed from 1000 RPM to -1000 RPM through stop point for SVPWM as in Fig. 5 (a) and for MPC as in Fig. 5 (b). It is possible to notice the better dynamic performances achievable by the proposed MPC. Fig. 6 shows the speed performance when it is loaded at 1000 RPM with 2N.m for SVPWM as in Fig. 6 (a) and for MPC as in Fig. 6 (b). It is can be noticed the better dynamic performances achievable by the proposed MPC compared to PI.

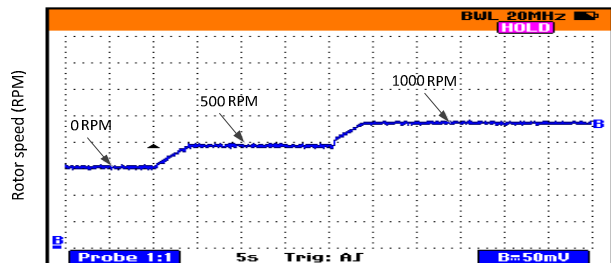

(a)

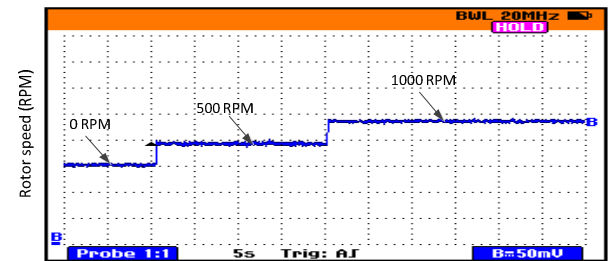

(b)

Fig. 4 Step-up speed performance of PMSM: (a) With PI controller, (b) With MPC controller

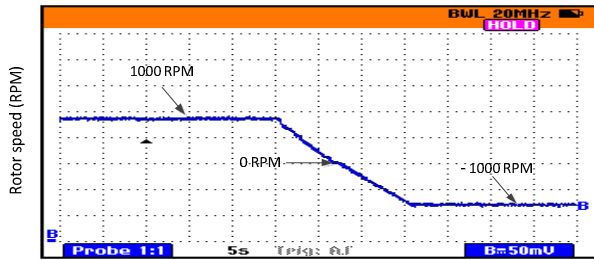

(a)

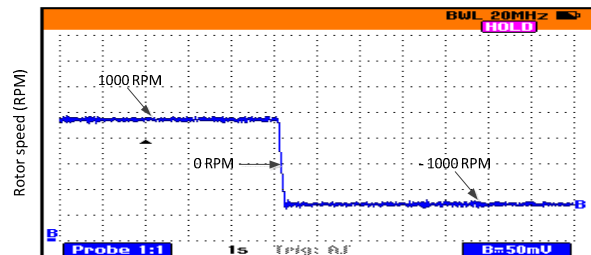

(b)

Fig. 5 Reversing speed performance of PMSM: (a) With PI controller, (b) With MPC controller

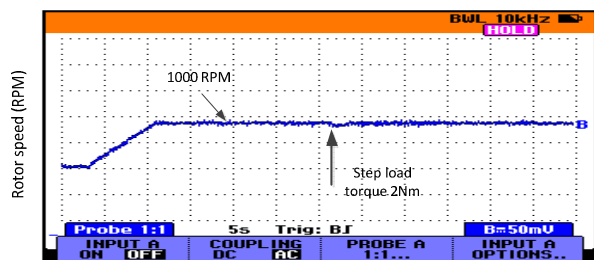

(a)

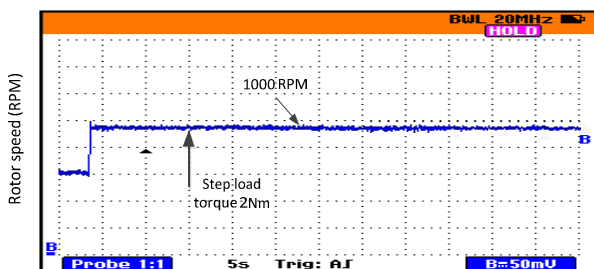

(b)

Fig. 6 Speed performance of PMSM at loading: (a) With PI controller, (b) With MPC controller

VI. CONCLUSION

This paper addressed the experimental implementation of MPC and FOC with SVPWM applied for PMSM. The developed control technique is based on optimization of the DC source utilization. Experimental results demonstrate the effectiveness of the proposed control. From experimental results, compared to SVPWM, the presented MPC offers an improved speed tracking response and better dynamic

performance for PMSMs overall operation widespread.

ACKNOWLEDGMENT

The author gratefully acknowledges Dr. An Quntao and Prof. Sun Li in School of Electrical Engineering & Automation, Harbin Institute of Technology, Harbin, China for their scientific enhancement and financial support provided by Harbin Institute of Technology, China.

REFERENCES

- [1] P. Cortes, M. P. Kazmierkowski, R. M. Kennel, D. E. Quevedo, and J. Rodriguez, "Predictive control in power electronics and drives," *IEEE Transaction on Industrial Electronics*, Vol. 55, No. 12, pp. 4312–4324, Dec. 2008.
- [2] J. Rodriguez and P. Cortes, *Predictive Control of Power Converters and Electrical Drives*, Hoboken, NJ, USA: Wiley, 2012.
- [3] Alfonso Damiano, Gianluca Gatto, Ignazio Marongiu, Aldo Perfetto, and Alessandro Serpi, "Operating constraints management of a surface-mounted PM synchronous machine by means of an FPGA-based model predictive control algorithm," *IEEE Transactions on Industrial Informatics*, Vol. 10, No. 1, Feb. 2014.
- [4] Irtaza M. Syed, Kaamran Raahemifar, "Space Vector PWM and Model Predictive Control for Voltage Source Inverter Control", *World Academy of Science, Engineering and Technology International Journal of Electrical, Computer, Electronics and Communication Engineering* Vol.8 No: 11, pp. 1562-1568, 2014.
- [5] S. Kouro, P. Cortes, R. Vargas, U. Ammann, and J. Rodriguez, "Model predictive control-a simple and powerful method to control power converters," *IEEE Trans. Ind. Electron.*, vol. 56, no. 6, pp. 1826–1838, Jun. 2009.
- [6] F. Morel, X. Lin-Shi, J.-M. Retif, B. Allard, and C. Buttay, "A comparative study of predictive current control schemes for a permanent magnet synchronous machine drive," *IEEE Trans. Ind. Electron.*, vol. 56, no. 7, pp. 2715–2728, Jul. 2009.
- [7] Abdelsalam Ahmed, An Quntao and Sun Li, "DSP-Based Implementation of Permanent Magnet Synchronous Motor Drives for EV/HEV Applications", *16th International Middle East Power Systems Conference (MEPCON'14)*, Cairo, Egypt, will be held on December 23-25, 2014.
- [8] B. Zhang, Y. Li and Y. Zuo, A DSP-based fully digital PMSM servo drive using on-line self-tuning PI controller, *Proc. PIEMC 2000*, vol.2, pp. 1012-1017, 2000.
- [9] A.M. Trzynadlowski, M.P. Kazmierkowski, P.Z. Grabowski, M.M. Bech, Three Examples of DSP Applications in Advanced Induction Motor Drives, *American Control Conference*, Vol. 3, pp. 2139-2140, 1999.
- [10] TMS320F2810 and TMS320F2812 Digital Signal Processors, *Handbook of Texas Instruments*, 2012.
- [11] Weifeng Zhang, Yuehui Yu, Zhiqiang Chen, DaidaXie, TMS320F2812 DSP Driving System based on Power Electronics Integration Technology, *ICSP2006 Proceedings*.
- [12] Zhao Yinyin, QuYongyin, PMSM Vector Control System Design Based on TMS320F2812, *World Automation Congress (WAC)*, 2012.
- [13] Tiecheng Sun, Ce Liu, Ningbo Lu, Deyan Gao, Sanling Xu, Design of PMSM Vector Control System Based on TMS320F2812 DSP, *2012 IEEE 7th International Power Electronics and Motion Control Conference - ECCE Asia*, June 2-5, 2012, Harbin, China.
- [14] Zhu Jun, Li Wankui, Han Lili, PMSM Control System Based on Digital Signal Processor, *Journal of Networks*, Vol. 8, No. 4, April 2013.