

The Analysis and Simulation of TRACE in the Ultimate Response Guideline for Chinshan BWR/4 Nuclear Power Plant

J. R. Wang, H. T. Lin, H. C. Chen, C. Shih, S. W. Chen, S. C. Chiang, C. C. Liu

Abstract—In this research, TRACE model of Chinshan BWR/4 nuclear power plant (NPP) has been developed for the simulation and analysis of ultimate response guideline (URG). The main actions of URG are the depressurization and low pressure water injection of reactor and containment venting. This research focuses to verify the URG efficiency under Fukushima-like conditions. TRACE analysis results show that the URG can keep the PCT below the criteria 1088.7 K under Fukushima-like conditions. It indicated that Chinshan NPP was safe.

Keywords—BWR, TRACE, safety analysis, URG.

I. INTRODUCTION

THERE are more concerns for the safety of the NPPs in Taiwan after Fukushima NPP disaster. In general, there are four categories for the NPP operating state, which involve normal operation, abnormal events/transients, accidents and severe accidents. For each operating state, there are corresponding procedures to follow to secure NPPs safety and integrity. Fig. 1 shows the correspondent relationship between NPP operating states and procedures. The first level is operating procedures (OPs) which focus on the NPP operation within an acceptable range. The second level is abnormal operating procedures (AOPs) which aim at restoring the function of NPP systems that could impact the NPP operating margins. The third level is emergency operating procedures (EOPs) which focus on bringing the NPP to a safe and stable state by following a reactor trip or safety injection signal. The fourth level is severe accident management procedures (SAMPS). Uncertainties may exist in both NPP status and in the outcome of actions for severe accidents. Therefore, SAMPS propose a range of possible actions and should allow for additional evaluation and alternative actions.

However, EOP or SAMP is generally based on events refers plant status and parameters to mitigate the events consequence. For the compound severe accidents, such as Fukushima nuclear accident, its impact to NPP is relatively spread, rather than focus on one system or one area influence.

J. R. Wang, H. C. Chen, C. Shih and S.W. Chen are with the Institute of Nuclear Engineering and Science, National Tsing-Hua University, and Nuclear and New Energy Education and Research Foundation, R.O.C., Taiwan (e-mail: jongrongwang@gmail.com, km8385@gmail.com, chensw@mx.nthu.edu.tw, ckshih@ess.nthu.edu.tw).

H.T. Lin is with the Institute of Nuclear Energy Research, Atomic Energy Council, R.O.C., Taiwan (e-mail: htlin@iner.gov.tw).

S.C. Chiang and C.C. Liu are with the Department of Nuclear Safety, Taiwan Power Company, R.O.C., Taiwan.

Therefore, with regard to this fact, Taiwan Power Company developed an additional ultimate measure category, URG, to prevent BWR, PWR and ABWR from encountering core damage for events beyond design basis [1]. Fig. 2 shows the URG procedure.

The aim of this study is using the computer programs to verify the URG efficiency of Chinshan NPP. Chinshan NPP is the first NPP in Taiwan which is a BWR/4 plant and OLTP (Original Licensed Thermal Power) for each unit is 1775 MWt. Chinshan NPP finished SPU (Stretch Power Uprate) and the operating power is 103.66% of OLTP, which is 1840MWt now.

The advanced thermal-hydraulic code named TRACE has been developed by U.S.NRC for NPP safety analysis. The development of TRACE is based on TRAC, combining with the capabilities of RELAP5 and other programs. One of the features of TRACE is its capacity to model the reactor vessel with 3-D geometry. It could support a more accurate and detailed safety analysis for nuclear power plants. In the future, TRACE is expected to replace NRC's present four main systems codes (TRAC-P, TRAC-B, RELAP5 and RAMONA) as the main code used in thermal hydraulic safety analysis [2]. Besides, a graphic user interface program, SNAP (Symbolic Nuclear Analysis Program), which processes inputs, outputs, and the animation model for TRACE, is also developed by U. S. NRC.

In [3]-[8], we established Maanshan NPP (PWR), Chinshan NPP (BWR/4), and Lungmen NPP (ABWR) TRACE/SNAP models successfully by using TRACE v 5.0 ~ v 5.0 patch 3 and SNAP v 0.26.7 ~ v 2.2.1. In a separate research work, a corresponding TRACE model of Chinshan NPP has been established, where the transient data from FSAR and RETRAN were used to verify the Chinshan NPP TRACE model [9]-[11]. Analytical results indicate that the Chinshan NPP TRACE model could predict not only the behaviors of important plant parameters reflecting consistent trends with FSAR and RETRAN data, but also their numerical values with respectable accuracy.

In this study, TRACE model of Chinshan BWR/4NPP has been developed in order to verify the URG efficiency. This research focuses to estimate the URG efficiency under Fukushima-like conditions. Besides, the sensitivity study of depressurization and low pressure water injection was also performed.

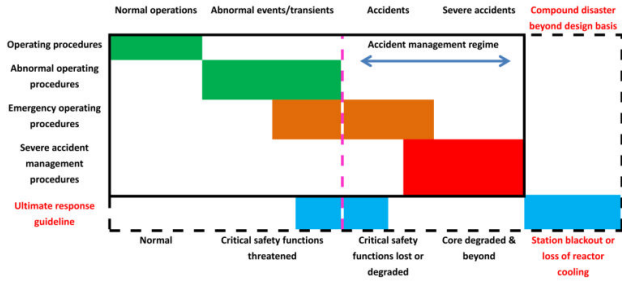

Fig. 1 Correspondent relation between NPP operating states and operating procedures

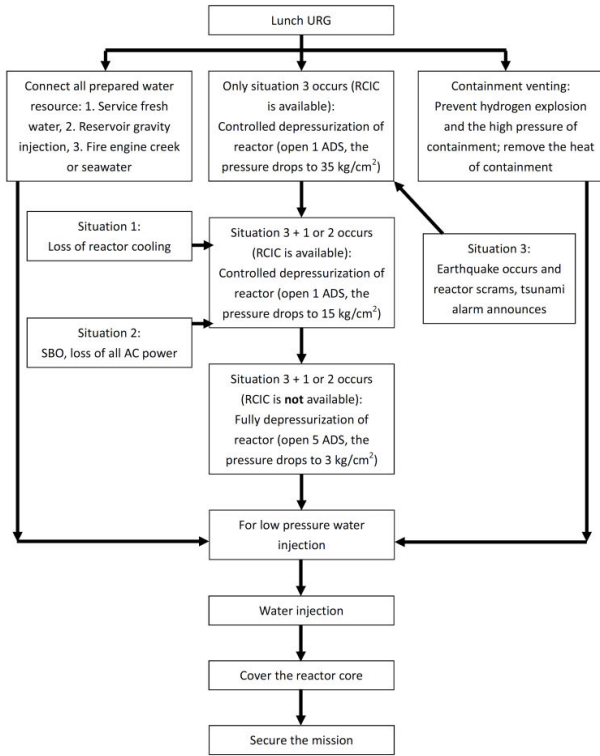

Fig. 2 URG flowchart

II. TRACE MODELING OF CHINSHANBWR/4 NPP

SNAPv 2.2.9 and TRACE v 5.0patch4 are used in this research. The process of Chinshan NPP TRACE model development is as follows: First, the system and operating data for the cases of FSAR of Chinshan NPP are collected [2]-[11]. Second, several important control systems such as recirculation flow control system, pressure control system and feed water flow control system etc. are established by SNAP and TRACE. Next, other necessary components (e.g., RPV (Reactor pressure vessel) and main steam piping) are added into the TRACE model to complete the TRACE model for Chinshan NPP. Finally, the Chinshan TRACE model is verified with the cases of FSAR. The TRACE model of Chinshan NPP is presented in Fig. 3.

The reactor vessel is divided into 9 axial levels, 4 radial

rings, and 2 azimuthal sectors. Six channels are used to modeling 408 fuel rods and connect to the vessel's level 3~4. There were 27 axial nodes and 6 radial nodes in one channel. The water rods and partial length rods were also simulated in the channels. Besides, six separators connect to the level 6~8 of the vessel. Two recirculation loops are set outside the vessel, with a recirculation pump in each loop. In the TRACE model, 10 groups of injection pumps are merged into an equal injection pump. We use valve components to simulate the SRV (safety relief valve), MSIV (main steamline isolation valve), TSV (turbine stop valve), TCV (turbine control valve) and BPV (bypass valve). The critical flow models for the MSIV, SRV, TCV, TSV, and BPV have been considered in our analysis. The reactor vessel connects with four steamlines. Besides, every steamline has one MSIV, one TCV/TSV, and 1~4SRVs. The steam goes through the top of the reactor and into the main steamlines. Finally, the steam passes through the TCVs and enters the turbines (boundary conditions). We also build bypass pipelines and the turbine bypass valve. Moreover, the break component at the end of bypass valve is used to simulate the condenser.

In Chinshan NPP TRACE model, "point kinetic" parameters such as delay neutron fraction, Doppler reactivity coefficient, and void reactivity coefficient are provided as TRACE input for power calculations. These data are set in the power component. In the Chinshan NPP TRACE model, there are three simulation control systems included (1) feed water flow control system, (2) pressure control system and (3) recirculation flow control system. Currently, these three control systems have been built by the signal variables, control blocks, trips and components of TRACE.

III. RESULTS

According to URG, the core concept is treating compound disaster beyond design basis (blue blocks in Fig. 1). When the NPP meets a Fukushima-like accident (the accident with loss of all AC power or reactor cooling conditions), EOP/SAMP and URG will be initiated at the same time. The main difference among EOP, SAMP and URG is that when the NPP status does not recovery in time, URG must be executed without most information of NPP. EOP and SAMP focus on maintaining the reactor core cooling, preventing the release of radioactive material, and protecting the property of NPP. However, URG may result in the permanent damage on the reactor of NPP and is an irreversible choice, so it needs the senior manager such as the vice president or the plant manager to make this decision. The following are the main objectives of URG:

- Maintain the reactor core cooling.
- Maintain the monitoring functions of the control room.
- Prevent the release of radioactive material.
- Remove the amount of cumulated hydrogen in building.
- Maintain the spent fuel pool cooling and water level.

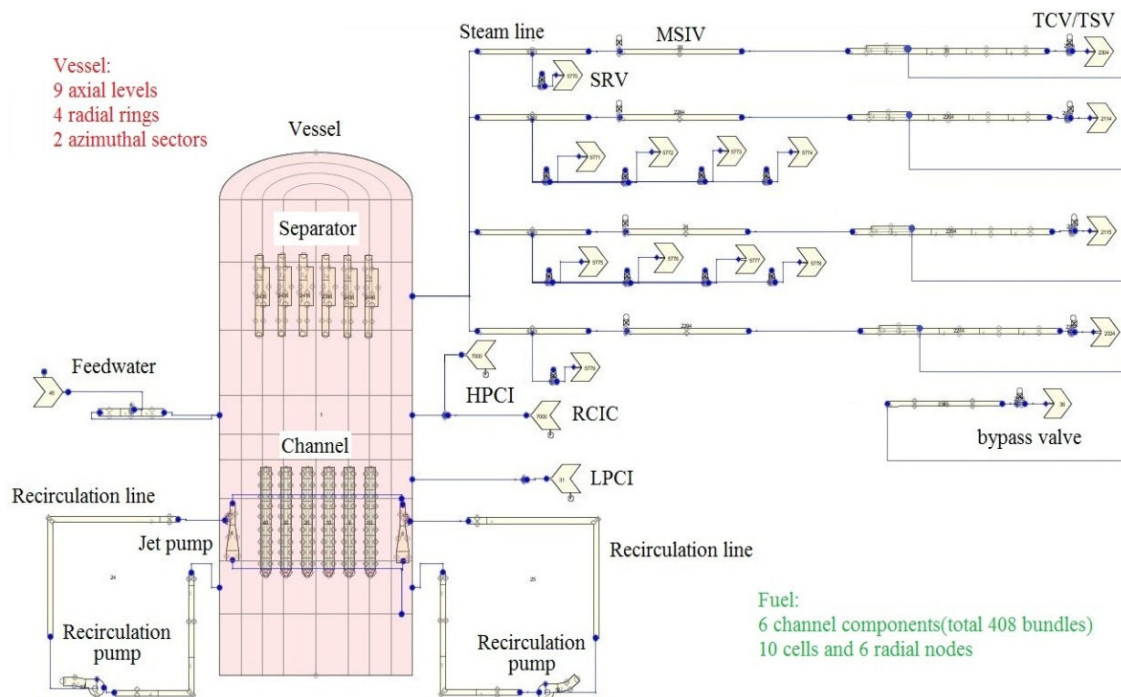

Fig. 3 Chinshan NPP TRACE model

When the NPP encounters the Fukushima-like accident, URG will be activated to prevent reactor core from being damaged. Once entering the procedure of URG, the NPP reactor will be depressurized first, and if the electrical power cannot be recovered before passive reactor core isolation cooling (RCIC) becomes inoperable, any water available will be injected into the reactor vessel. Fig. 2 depicts the URG procedure.

In order to estimate the URG efficiency under Fukushima-like conditions and perform the sensitivity study of depressurization and low pressure water injection, there were six cases in this paper. Table I presents the initial conditions of cases. Table II lists the sequence of URG simulation of TRACE under Fukushima-like conditions (base case, Case 2). Besides, there are some assumptions have been made in this analysis, including: (1) the safety relief valves activate in this transient; (2) the decay heat model ANS-73 is used in this transient simulation; (3) the low pressure water injection is 28.35 kg/sec. The main actions of URG are the depressurization and low pressure water injection of reactor and containment venting. However, we focus on the sensitivity study of depressurization and low pressure water injection, shown in Table III. Besides, the depressurization of reactor consists of controlled and fully depressurization.

For Case 2 (base case), the simulation of steady state was first performed during 0~300 sec. Then, due to earthquake occurs and tsunami alarm announces (assumed conditions), reactor scrammed at 300 sec. Controlled depressurization of reactor and MSIV closure were also performed at 300 sec. In this controlled depressurization step, 1 ADS opened which caused that the dome pressure dropped to 35 kg/cm² and kept

at this level (shown in Fig. 5). RCIC was activated at 305 sec and the water level was kept at level 2~level 8 during 305~28800 sec (see Fig. 4). Subsequently, station blackout (SBO) was assumed to occur at 2100 sec. At this step, controlled depressurization of reactor was performed again. Therefore, 1 ADS opened and the dome pressure dropped to 15 kg/cm² and kept at this level (see Fig. 5). According to FSAR, RCIC can run 8 hours. Hence, we assumed RCIC failure at 28800 sec which depicted RCIC running approximately 7.92 hours. Because RCIC failed, fully depressurization of reactor was performed in order to start low pressure water injection. At this step, 5 ADS opened and the dome pressure dropped to 3 kg/cm² (shown in Fig. 5) which caused the water level lower than TAF (top of active fuel) (see Fig. 4). Therefore, PCT increased at this time (shown in Fig. 6). Then, low pressure water injected to the reactor at 30420 sec. The sources of low pressure water were assumed from service fresh water, reservoir gravity injection, fire engine creek or seawater (see Fig. 2). The water level went up and PCT decreased after the low pressure water injection (see Figs. 4 and 6). Finally, the transient finished at 86400 sec.

No URG case is Case 1. The dome pressure of Case 1 was kept at about 7 MPa and there was an oscillation in Case 1 due to SRVs activated. After RCIC failure, the water level of Case 1 started to decrease and was lower than TAF at about 36900 sec. the PCT of Case 1 increased after the water level lower than TAF and reached 1088.7 K at 63500 sec. It indicated that the zirconium-water reaction was able to generate. The above results of Case 1 depicted that Chinshan NPP was not safe. In the comparison of Case 1 and 2, it shows that URG can keep Chinshan NPP at the safety situation under Fukushima-like

conditions.

Comparing Case 2 and 4 or 1 and 3, if there was only the fully depressurization of reactor in URG (no controlled depressurization), TRACE results depicted that the water level dropping was larger (see Fig. 4) than the controlled depressurization cases. It indicates that PCT increases faster. Furthermore, if no water injection was also in the above cases, the PCT was larger than 1088.7 K (see Case 1 and 3, Fig. 6) which indicated that Chinshan NPP was not at the safety situation.

Comparing Case 1 and 5, if there was only the controlled depressurization of reactor in URG (no fully depressurization), TRACE results presented that the trends of water level and PCT were similar for Case 1 and 5. But the water level of Case 5 went down slower than Case 1 and there was a larger oscillation in Case 5.

Comparing Case 2 and 6, if there was no water injection in URG and the depressurization of reactor performed, TRACE results indicated that PCT went up very fast after the depressurization of reactor (see Case 6, Fig. 6). It presented that the zirconium-water reaction generated and Chinshan NPP was not at the safety situation. The above results also indicated that if the NPP want to be at the safety situation, the low pressure injection must be performed after the depressurization of reactor finishes.

In addition, the animation of Chinshan NPP TRACE model is presented by using the animation function of SNAP with above models and TRACE analysis results. Chinshan NPP animation model is shown in Fig. 7. The results of TRACE can be observed in Fig. 7.

TABLE I
THE INITIAL CONDITIONS OF CASES

Parameter	TRACE
Power(MWt)	1840
Dome Pressure(MPa)	6.96
Feedwater Flow(kg/sec)	990.6
Steam Flow(kg/sec)	989.7
Core inlet flow(kg/sec)	6665.8

TABLE II
THE SEQUENCE OF CASE 2

Action	Time (sec)
Start	0
Reactor scrams (because earthquake occurs and tsunami alarm announces), MSIV closes,	300
Controlled depressurization of reactor (open 1 ADS, the pressure drops to 35 kg/cm ²)	
RCIC activates	305
SBO (loss of all AC power),	
Controlled depressurization of reactor (open 1 ADS, the pressure drops to 15 kg/cm ²)	2100
RCIC failure,	
Fully depressurization of reactor (open 5 ADS, the pressure drops to 3 kg/cm ²),	
Containment venting	28800
Low pressure water injection	30420
End	86400

TABLE III
THE SENSITIVITY STUDIES OF URG

Action	Case1	Case2	Case3	Case4	Case5	Case6
Controlled depressurization of reactor	x	o	x	x	o	o
Fully depressurization of reactor	x	o	o	o	x	o
Low pressure water injection	x	o	x	o	x	x

o: Perform this action
x: Don't perform this action

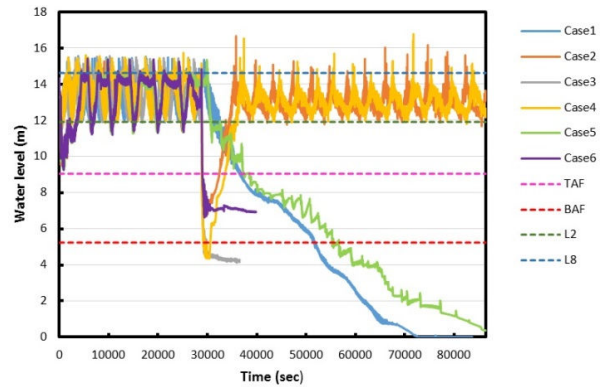

Fig. 4 The water level results

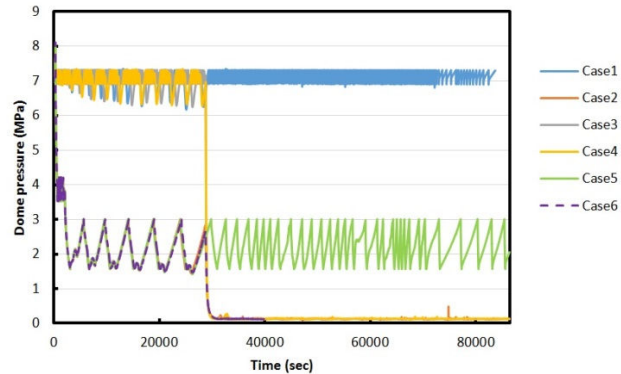

Fig. 5 The dome pressure results

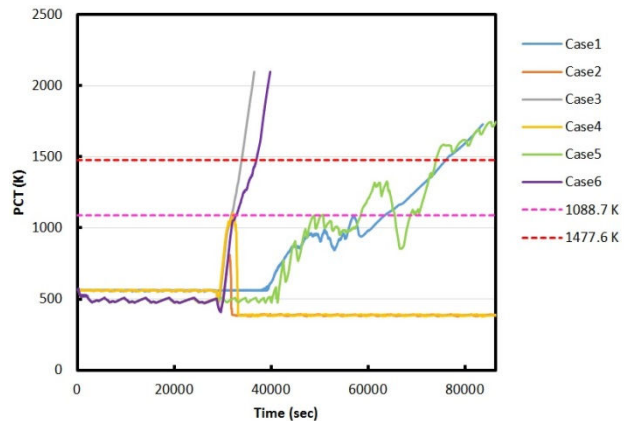

Fig. 6 The max fuel cladding temperature (PCT) results

IV. CONCLUSION

By using SNAP/TRACE, this study has developed the model to estimate the effectiveness of URG for Chinshan NPP. TRACE analysis results show that the URG can keep the PCT below the criteria 1088.7 K under Fukushima-like conditions. It indicated that Chinshan NPP was safe. On the sensitivity study of URG depressurization and low pressure water injection, the summary is as follows:

1. In no water injection cases, if the controlled and fully depressurization of reactor are both performed, its PCT will increase faster than the no depressurization case. Besides, if the controlled depressurization of reactor is only performed (no fully depressurization), the water level and PCT of this case will be similar with the no depressurization case. However, there is a larger oscillation in the controlled depressurization case.
2. In depressurization cases, if the controlled and fully depressurization of reactor are both performed, the dropping level of water level will be lower than the case which is only fully depressurization. It depicted that the PCT go up faster for the fully depressurization case.

REFERENCES

- [1] K.S. Liang, S.C. Chiang, Y.F. Hsu, H.J. Young, B.S. Pei, L.C. Wang, "The ultimate emergency measures to secure a NPP under an accidental condition with no designed power or water supply," Nuclear Engineering and Design, 253, pp.259-268,2012.
- [2] U.S. NRC, "TRACE V5.0 User's Manual", 2010.
- [3] J. R. Wang, H. T. Lin, Y. H. Cheng, W. C. Wang, C. Shih, "TRACE modeling and its verification using Maanshan PWR start-up tests", Annals of Nuclear Energy, 36, pp. 527-536, 2009.
- [4] C. H. Chen, J. R. Wang, H. T. Lin, C. Shih, "ATWS analysis for Maanshan PWR using TRACE/SNAP code", Annals of Nuclear Energy, 72, pp. 1-10, 2014.
- [5] H. T. Lin, J. R. Wang, C. Shih, "The development and assessment of TRACE model for Lungmen ABWR", Kerntechnik, 76, pp. 205-215, 2011.
- [6] H. T. Lin, J. R. Wang, H. C. Chen, C. Shih, "The development and assessment of TRACE/PARCS model for Lungmen ABWR", Nuclear Engineering and Design, 273, pp. 241-250, 2014.
- [7] C. Y. Chen, C. Shih, J. R. Wang, H. T. Lin, "Sensitivity study on the counter-current flow limitation in the DEGLBLOCA with the TRACE code", Annals of Nuclear Energy, 57, pp. 121-129, 2013.
- [8] C. Y. Chen, C. Shih, J. R. Wang, "The alternate mitigation strategies on the extreme event of the LOCA and the SBO with the TRACE Chinshan BWR4 model", Nuclear Engineering and Design, 256, pp. 332-340, 2013.
- [9] J. H. Lee, J. R. Wang, H. T. Lin, S. M. Yang, C. Shih, "TRACE modeling of Chinshan load rejection startup test", American Nuclear Society: 2009 Annual Meeting.
- [10] Taiwan Power Company, "Final Safety Analysis Report for Chinshan Nuclear Power Station Units 1&2", 1999.
- [11] W. S. Hsu, J. R. Tang, "The calculation notes of the startup test benchmark analysis for the Chinshan RETRAN-02 model", INER report, 1997.

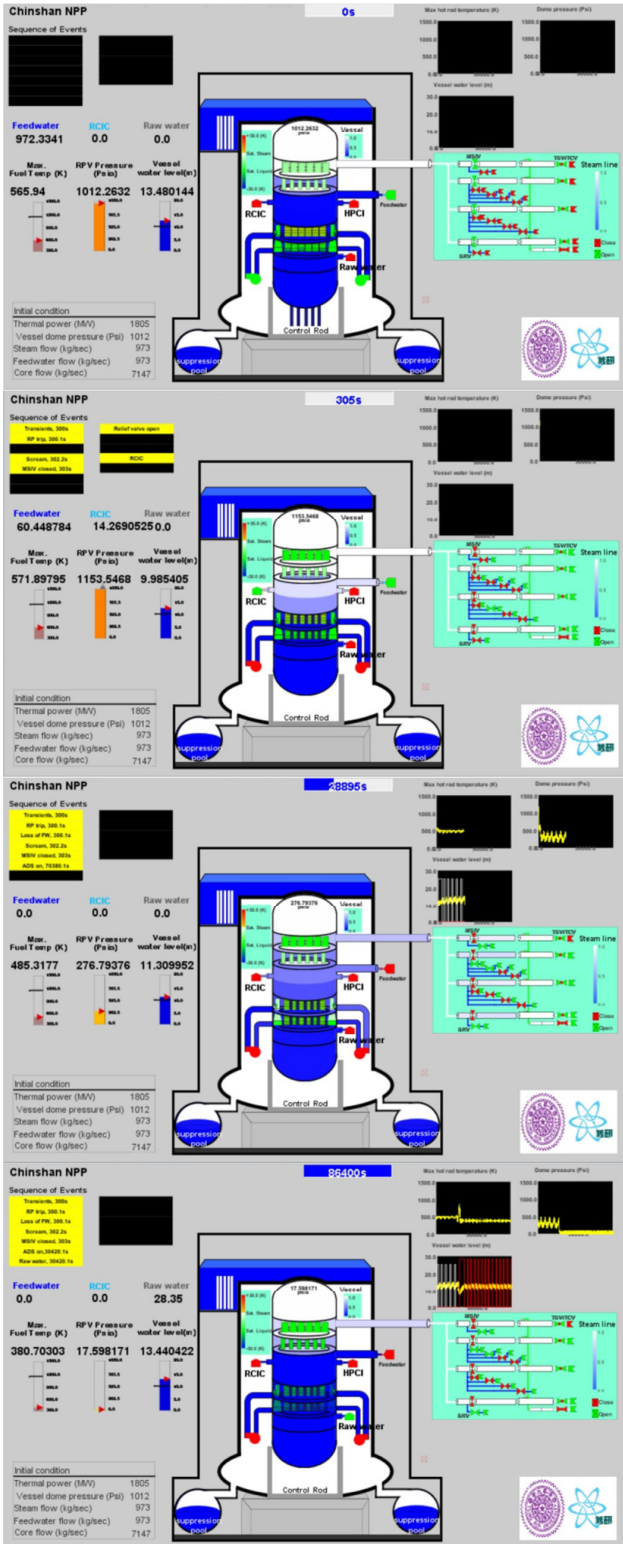

Fig. 7 The animation model of Chinshan NPP