

Real-time Detection of Space Manipulator Self-collision

Zhang Xiaodong, Tang Zixin, Liu Xin

Abstract—In order to avoid self-collision of space manipulators during operation process, a real-time detection method is proposed in this paper. The manipulator is fitted into a cylinder-enveloping surface, and then, a kind of detection algorithm of collision between cylinders is analyzed. The collision model of space manipulator self-links can be detected by using this algorithm in real-time detection during the operation process. To ensure security of the operation, a safety threshold is designed. The simulation and experiment results verify the effectiveness of the proposed algorithm for a 7-DOF space manipulator.

Keywords—Space manipulator, Collision detection, Self-collision, the real-time collision detection.

I. INTRODUCTION

TO accommodate the wide range of operational environment in space, the capacity and security of space manipulators should be improved. However, space manipulator is kind of complex multi-body system, which may cause the collision between the links, the spacecraft module or external objections while in the on-orbit tasks. Collision is dangerous and will cause the great economic losses and the expensive cost. Therefore, in order to complete on-orbit missions successfully, the research of collision detection technology is significantly important on space manipulator system.

Lots of previous works were carried out on space manipulator collision detection technology. Alessandro [1] proposed a method, which considered the problem of real-time detection of collisions between a robot manipulator and obstacles of unknown geometry and location in the environment without the use of extra sensors. Crnekovic [2] built a geometry model to find out the collision if a manipulator was in the range of collision with its environment. Domina Henrich [3] presented a fast method for computing the so-called collision vector for the on-line real-time collision detection for a multi-arm robot system. Manipulator and the obstacle models were building by sets of convex palmtops. Based on the feasible obstacles model, Zonggao Mu [4] realized three effective collision detection methods to supply early warning before the danger comes. These methods were the line group method based on OSG (Open scene Graph), bounding box method

Zhang Xiaodong is with Beijing Key Laboratory of Intelligent Space Robotic Systems Technology and Applications, Institute of Spacecraft System Engineering CAST, Beijing, china. Road YouYi 104 (phone: 86-010-68113135; 15810002976; e-mail: 15810002976@139.com).

Tang Zixin is with Institute of Spacecraft System Engineering CAST, Beijing, Road YouYi 104 (phone: 86-010-68113128; e-mail: 15810002976@139.com).

Liu Xin is with Institute of Spacecraft System Engineering CAST, Beijing, Road YouYi 104 (phone: 18610725276; e-mail: tracy_liuxing@sina.com).

based on OBB (Oriented Bounding Box) and cylinder method based on the dual vector. In [5], to detect the collision of the manipulator without force/torque sensor, two parameters were only required for calculation of collision observer, one was the current value; the other was control input value. Because the current from the motor servo amplifier was generated to follow the controller command input, the current can be used to detect the collision. A disturbance observer based on generalized momentum was proposed in [6] to efficiently detect a collision, the proposed algorithm of the disturbance observer allowed any multi-DOF robot to effectively detect a collision without the use of additional sensors or mechanisms.

However, the studies mentioned above were mainly concerned on the collision detection between manipulator and environment, but not for the self-collision interference between its links. In this paper, a real-time collision interference detection technology focused on self-collision is proposed to avoid the collision between the links.

This paper is organized as follows. Section II simplifies the model of the manipulator, and collision detection algorithm is proposed in this section. Section III introduces the real-time collision interference detection algorithm. Section IV shows the simulation results. Section V presents the conclusions of the work.

II. THE PRINCIPLE OF COLLISION DETECTION

In order to facilitate the analysis and calculation, the first step is to simplify all space manipulator parts. Meanwhile, simplification is required to ensure that the model is not distorted as possible, to reduce the errors due to the simplified models and the real models. The manipulator in this paper is shown in Fig. 1; each link can be simplified as a cylinder. The size of simplified model is based on adding a certain safety margin on the size of the maximum envelope dimensions of each member of the mechanical arm system. Therefore, the self-collision detection between the space manipulator links can be transformed into the collision detection of different cylinders.

A. Cylinder-Cylinder Collision Detection

A collision between two cylinders can be divided into three cases: collision between cylindrical surface and cylindrical surface, collision between cylindrical surface and the end point, and collision between two end points of cylinder. The following will discuss the condition of collision between two cylinders occurs in all types when cylindrical axes are in different planes, parallel and intersection.

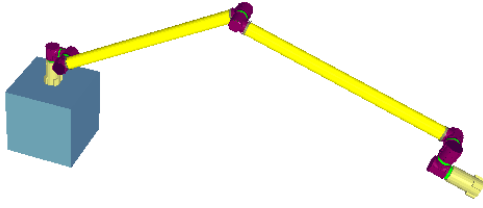

Fig. 1 The simplified models of space manipulator

1) Cylindrical Axes Are in Different Planes

When two cylindrical axes are in different planes, two points M_i and M_j should be located respectively on the axis Z_i and Z_j of cylinder C_i , and the points should make sure that the length of $M_i M_j$ is the shortest, so that M_i, M_j is the respective pedal. Leaving out the constraints, the most minimum condition can be used to acquire the distance $d_{min} = \|M_j - M_i\|$ between two pedals on two straight lines. If $d_{min} > (R_i + R_j)$, two cylinders will not collide. R_i and R_j are radius of two cylinders, and if $d_{min} \leq (R_i + R_j)$, two cylinders might collide.

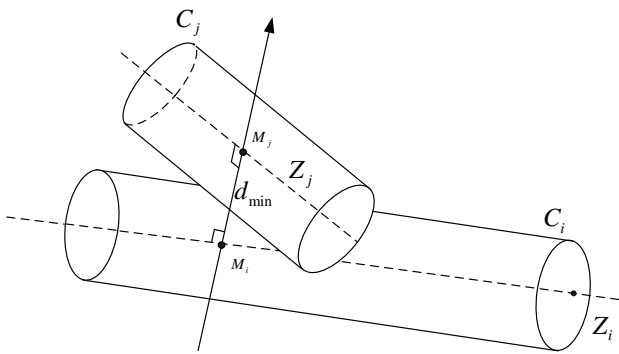

Fig. 2 The model of collision between two cylinders when cylindrical axes are in different planes

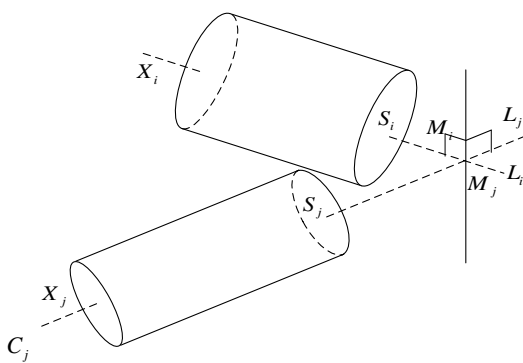

Fig. 3 The model of collision between cylindrical surface and the end face when cylindrical axes are intersecting

2) Cylindrical Axes Are Intersecting

When two cylindrical axes are intersected, only the collision between cylindrical surface and the end point face, and

collision between two end faces of cylinder will possibly happen. In this case, two cylinder endpoints X_i, S_i and X_j, S_j should be projected on another cylindrical axis. The position coordinates of four projection points can be used to confirm the condition of the collision between cylindrical surface and the end face. The model is shown in Fig. 3.

3) Cylindrical Axes Are Parallel

When two cylindrical axes are parallel, only the collision between cylindrical surface and cylindrical surface and collision between two end faces of cylinder will possibly happen. At this moment, if $d_{min} < (R_i + R_j)$ is satisfied, the collision will not happen. If not, it will. On this basis, we can judge whether the projection of two endpoints X_j or S_j of the axis L_j on axis Z_i is between X_i and S_i or not. If yes, two cylindrical surfaces will collide. If not, it will not happen. The collision between two cylindrical need be judged again while two cylindrical surfaces don't collide.

B. Calculation of the Basic Geometry of Key Points

In order to detect collision between two cylinders, it's necessary to calculate the coordinates of key points. The information of key points is shown as follow:

- The cylinder center reference coordinate $P_i[3]$;
- The cylinder direction vector $e_i[3]$;
- The cylinder radius R_i ,

Two center points coordinates X_i, S_i on end faces of the cylinder. The formula of these variables is as follows:

$$\begin{cases} X_i = P_i + X_i e_i \\ S_i = P_i + S_i e_i \end{cases} \quad (1)$$

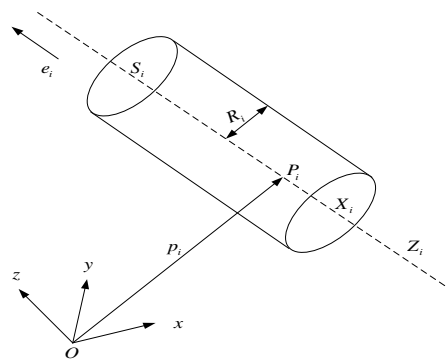

Fig. 4 The mathematical representation of cylindrical geometry model

C. Cylinder-Sphere Collision Detection

A collision model between cylinder and sphere is shown as Fig. 5. M_j is the reflection point of the center of sphere O_j to the axis Z_i of cylinder. First of all, the distance of the center of sphere and the cylinder axis is calculated as:

$$m_{ij} = \|p_j - m_j\| \quad (2)$$

If $m_{ij} \leq R_i + R_j$, the collision will not happen, R_i is the radius of cylinder and R_j is the radius of sphere, or the judgment will continue as follow:

If the M_i is inner the cylinder C_i , the collision will happen, if the M_i is outside of the cylinder C_i , the distance of between M_i and X_i, S_i . Suppose the distance between M_i and S_i is closer, the key point on the cylinder axis is S_i , Furth more the key distance $m_{ij} = \|p_j - s_i\|$ need to be calculated, if the collision condition of $m_{ij} \leq R_i + R_j$ is satisfied, the collision will happen.

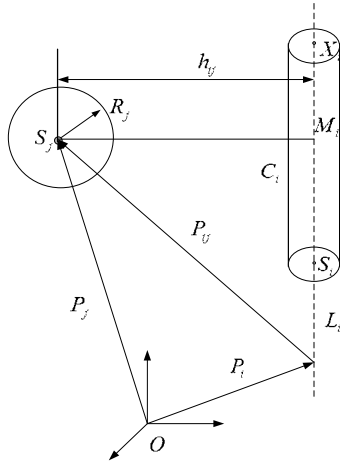

Fig. 5 The model of collision between cylinder and the surface of the cuboid

D. Cylinder-Cuboid Collision Detection

A collision between cylinder and cuboid can be transformed into interference analysis of the problem between cylinder and the surface of cuboid. Cylindrical and rectangular collision can be divided into two situations:

The first is collision between cylinder and four sides of rectangular, the second is the collision between two end faces of cylinder and rectangular.

In the first case, getting the distance from the cylindrical axis to four sides of the rectangular can solve the collision.

Secondly, calculate the distance between the endpoint B_i and T_i of the cylinder on the plane. Collision will happen if the minimum distance from two endpoints to the plane: $h_i < R_i$ is satisfied, the collision will happen, otherwise there's no collision.

E. Efficiency Analysis

Obviously, the more simplified the model, the more time will cost in analyzing the collision and interference. When the simplified model is more precise, the number of the simplified model will have a corresponding increase, the computing amount and time will be doubled in order to analysis the collision and interference, if the hardware equipment can't meet the requirements, the real-time of the collision and interference analyzing will be affected. Therefore, we need to

consider the analysis efficiency of the collision and interference analysis on the premise that the precision of the model is guaranteed.

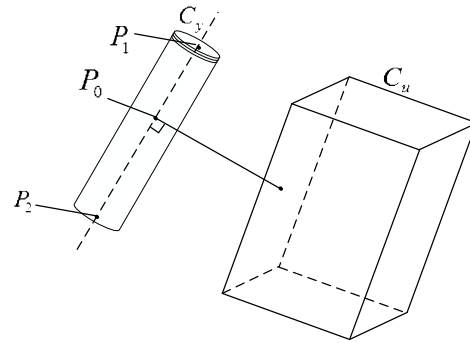

(a) Cylinder and four sides of rectangular

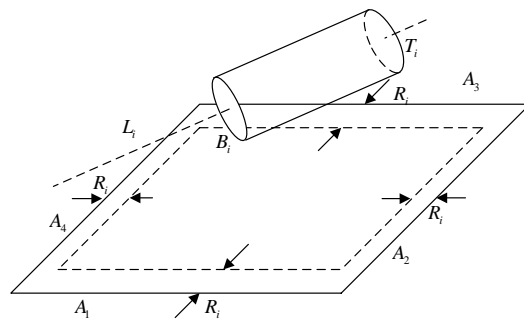

(b) Cylinder and the plane

Fig. 6 The model of collision between cylinder and the surface of the cuboid

The configuration is shown as:

- CPU: 3.4GHz;
- Memory: 4G;
- Operating system: 64bit.

The time of interference analysis between two cylinders or between cylinder and cuboid can be obtained. The time of interference analysis between two cylinders is 0.0008s, and the time of interference analysis between cylinder and cuboid is 0.255064s.

Comparison of the above two interference analysis time can be seen that collision between cylinder and cuboid interference analysis time required is relatively large, so the model should be simplified into a cylinder in the case of precision allowed, in order to improve the efficiency.

III. COLLISION INTERFERENCE DETECTION FOR MANIPULATOR LINKS

Based on the simplified model and collision detection between basic geometry, collision detection for manipulator can be implemented. Fig. 7 shows an n-DOF manipulator.

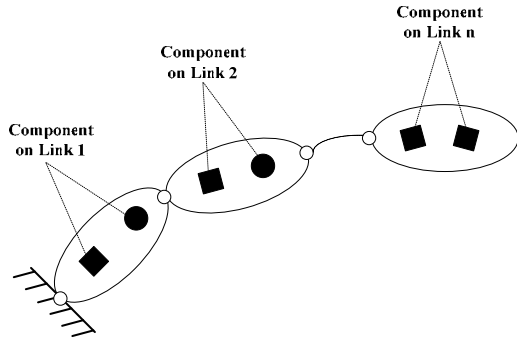

Fig. 7 A n-ROF manipulator

After calculating the position of a reference point on the simplified model, collision detection algorithm is designed. Due to the complex construction of space manipulator, we analyze the links, which may cause collision and exclude the links, which cannot cause collision before the design. Thus, the efficiency of collision detection can be improved. For the links, which may cause collision, after selecting and the calculating the position of reference point on the simplified model, the collision detection can be implemented according to the coordinates of the reference points. Fig. 8 shows the flow chart and the design algorithm is as follows.

- s1. According to the current joint angle and base position and orientation, calculate the all the key points of coordinates;
- s2. According to coordinates of key points, detect collision between manipulator links, if collision occurs, turns to s4, or turns to s3;
- s3. Update joint angle and base position and orientation and turns to s1 to operate the next step collision detection;
- s4. The collision occurs and the operation of space manipulator is aborted.

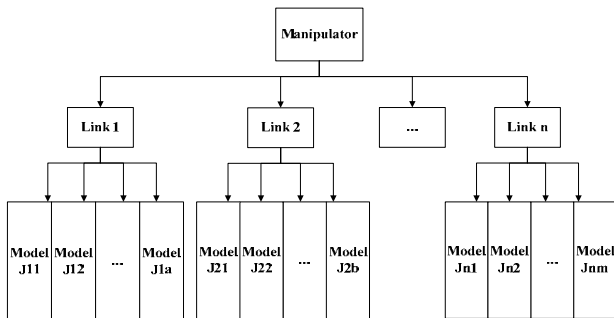

Fig. 8 Flow chart of space manipulator

If the possible collision is detected during the manipulator operation, the operation is required to be aborted. Nevertheless, space manipulator operation is consecutive in the current control period, so movement distance in a control period is considered in the collision detection threshold.

Complexity of manipulator operation determines the difficulty for confirming the collision detection threshold. The scheme confirms the collision detection threshold as:

$$D_{min} \geq \dot{\varphi} R_m T \tag{3}$$

where D_{min} is the collision detection threshold, $\dot{\varphi}$ is a parameter associated to maximum manipulator joint angle velocity, R_m is rotation radius of detection links around joint i , T is the control period of manipulator operation.

IV. SIMULATION

The relevant parameters of space manipulator are:

$$a_3 = a_4 = 5m, d_1 = d_7 = 0.6m, d_4 = 0.1m, d_2 = d_3 = d_5 = d_6 = 0.5m.$$

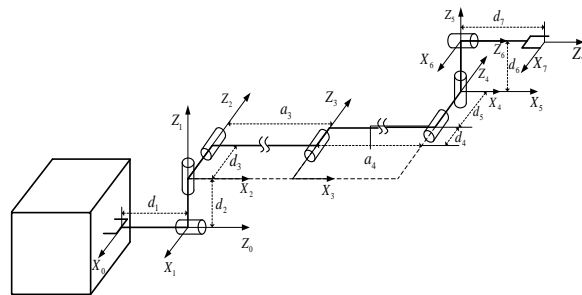

Fig. 9 Parameters of space manipulator

TABLE I
THE D-H PARAMETERS OF SPACE MANIPULATOR

link	θ_i	$d_i(m)$	$a_{i-1}(m)$
1	$\theta_1(-90)$	0.6	0
2	$\theta_2(0)$	0.5	0
3	$\theta_3(0)$	0.5	5
4	$\theta_4(-90)$	0.1	5
5	$\theta_5(-90)$	0.5	0
6	$\theta_6(-90)$	0.5	0
7	$\theta_7(0)$	0.6	0

By adopting the above collision detection algorithm, the manipulator links collision interference construction in various stages can be detected. The 8 links from the base to the end can be defined L_1 to L_8 , and the base is defined L_0 .

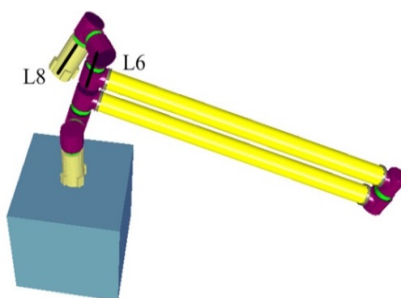

Fig. 10 Link L_6 and L_8 are impending to collide

As Fig. 10 shows a construction whose joint angle is $[89^\circ, -74^\circ, 180^\circ, 180^\circ, 34^\circ, -73^\circ, 153^\circ]$, where link L_6 and L_8 are

impending to collide.

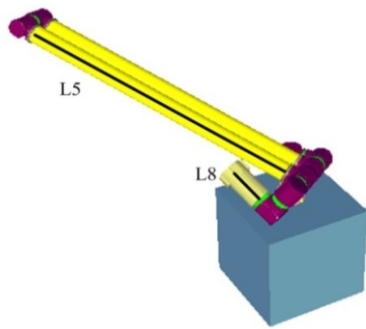

Fig. 11 Link L_5 and L_8 are impending to collide

As Fig. 11 shows another construction whose joint angle is $[-49^\circ, -13^\circ, 69^\circ, 180^\circ, -15^\circ, -174^\circ, -180^\circ]$, where link L_5 and L_8 are impending to collide.

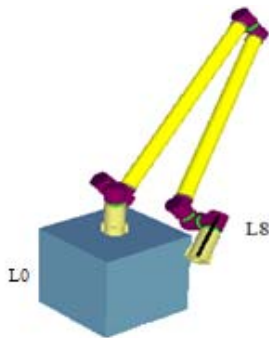

Fig. 12 Link L_8 and L_0 are impending to collide

As Fig. 12 shows a construction whose joint angle is $[-17^\circ, 51^\circ, -29^\circ, 169^\circ, 9^\circ, 6^\circ, 0^\circ]$, where link L_8 and L_0 are impending to collide.



Fig. 13 Link L_4 and L_0 are impending to collide

As Fig. 13 shows a construction whose joint angle is $[-97^\circ, -11^\circ, -137^\circ, 91^\circ, 9^\circ, 6^\circ, 20^\circ]$, where link L_4 and L_0 are impending to collide.

V.CONCLUSION

This paper has implemented space manipulator self-collision detection in operation by adopting the proposed collision detection algorithm based on the simplified space manipulator

link model. It has also analyzed rod collision of special construction in simulation. The safety threshold set can guarantee the avoidance of the space manipulator from self-collision in operation.

REFERENCES

- [1] De Luca, A., Mattone, R., "Sensorless Robot Collision Detection and Hybrid Force/Motion Control," Robotics and Automation, 2005. ICRA 2005. Proceedings of the 2005 IEEE International Conference on , vol., no., pp.999,1004, 18-22 April 2005
- [2] Crnekovic Mladen , Šitum Zeljko, Brezak Danko, "Two models for robot collision detection complexity comparison,"CIM 2002 Computer Integrated Manufacturing and High Speed Machining - 8th International Scientific Conference on Production Engineering
- [3] Henrich Dominik, Cheng Xiaoqing "Fast Distance Computation for On-line Collision Detection with Multi-Arm Robots," IEEE International Conference on Robotics and Automation, v 3, p 2514-2519, 1992
- [4] Zonggao Mu, Wenfu Xu, Xuehai Gao, Lijun Xue, Chun Li, "Obstacles modeling and collision detection of space robots for performing on-orbit services," Information Science and Technology (ICIST), 2014 4th IEEE International Conference on , vol., no., pp.461,466, 26-28 April 2014
- [5] Je. Hwan-Wook Baek, Jun-Young, Lee. Min-Cheol, "A study of the collision detection of robot manipulator without torque sensor," ICCAS-SICE 2009 - ICROS-SICE International Joint Conference 2009
- [6] Cho. Chang-Nho, Kim.Joon-Hong, Lee. Sang-Duck, Song. Jae-Bok, "Collision detection and reaction on 7 DOF service robot arm using residual observer," Journal of Mechanical Science and Technology, v 26, n 4, p1197-1203, April 2012

Zhang xiaodong(1980~), eared a doctor degree of space manipulator in 2008, from Beijing University of Posts and Telecommunication. The major field of study is space robot technology including space robot system design, dynamics and control.

He is with Beijing Key Laboratory of Intelligent Space Robotic Systems Technology and Applications, Institute of Spacecraft System Engineering CAST, Beijing, China. Current and previous research interests are space robot system.