

Decision Support System for a Pilot Flash Flood Early Warning System in Central Chile

D. Pinto, L. Castro, M.L. Cruzat, S. Barros, J. Gironás, C. Oberli, M. Torres, C. Escauriaza, A. Cipriano

Abstract—Flash Floods, together with landslides, are a common natural threat for people living in mountainous regions and foothills. One way to deal with this constant menace is the use of Early Warning Systems, which have become a very important mitigation strategy for natural disasters.

In this work we present our proposal for a pilot Flash Flood Early Warning System for Santiago, Chile, the first stage of a more ambitious project that in a future stage shall also include early warning of landslides.

To give a context for our approach, we first analyze three existing Flash Flood Early Warning Systems, focusing on their general architectures. We then present our proposed system, with main focus on the decision support system, a system that integrates empirical models and fuzzy expert systems to achieve reliable risk estimations.

Keywords—Decision Support System, Early Warning Systems, Flash Flood, Natural Hazard.

I. INTRODUCTION

IN recent years, natural disasters have affected millions of people, with losses dramatically increasing in time [1], [2]. These events not only bring about losses of property, goods, jobs and resources, but also displace people, cause harm and even loss of human lives. For these reasons, the world community has begun to pay more attention to these events and to develop strategies and plans to reduce the effect of natural hazards.

Early Warning Systems (EWS) are one of these strategies for disaster mitigation. In many types of natural disasters, the warning guidance is commonly achieved through Early Warning Systems, which provide a reliable alert to authorities and people before an event occurs. Generally, the EWS faces natural phenomena that develop rapidly and can often not be predicted with certainty or long before their occurrence, like earthquakes or flash floods. In case of tropical storms or typhoons, regular meteorological forecasting systems can predict the day and location of arrival and its force. But an EWS for flash floods, for example, should be capable to give a similar answer in a much shorter period of time. To achieve this, the EWS would use not only information from

meteorological forecast, but also from sensors located on specific positions and intelligent systems to alert, in real time, the changes of the actual risk for the vulnerable zone.

EWS face several challenges in order to be an effective tool for disaster mitigation. One of the requirements is speed, because there is almost always little time to give alerts (e.g. the first wave in tsunamis may reach the coast just 20 minutes after the earthquake [3]). EWS must also be accurate, precise and dependable, because large false alarm rates, response variability and system failures cause loss of trust or simply render the EWS useless. For all these reasons, EWS are information technology systems with higher performance and reliability standards than conventional monitoring systems.

In this work we propose a pilot Flash Flood Early Warning System (FFEWS). We envision this pilot project as the first of many similar systems for drainage basins that present flash flood risk for people in Chile. Our work is presented in three sections. The first two present, summarize and analyze other similar systems and their general architecture. In the last section we show the current work made for the pilot FFEWS and our proposal for its Decision Support System.

II. MOTIVATION

Flash Floods are a common threat for communities in mountain areas and foothills. Due to the strength and speed which they develop, this natural phenomenon could mean high losses in lives and wealth. According to the World Meteorological Organization, about 1.5 billion people were affected by Floods and Flash Floods [4]. To fight against this natural hazard, many countries have developed FFEWS, which allows authorities to elaborate a proper response to the imminent danger to come, and population to evacuate risk areas. Here we summarize a group of FFEWS that we have studied to understand its structure.

A. Central America Flash Flood Guidance

In 2004, the Hydrologic Research Center (HRC) implemented the Central America Flash Flood Guidance (CAFFG) system [5], [6], with support from the local governments, the US Agency for International Development and the National Oceanic and Atmospheric Administration (NOAA) through the National Weather Service (NWS) and the Office of Global Programs. This system provides tools for monitoring and forecasting of flash floods in seven countries of Central America: Belize, Costa Rica, El Salvador, Guatemala, Honduras, Nicaragua and Panama.

The CAFFG uses precipitation estimations made with satellite data from the Geostationary Operational

D. Pinto, L. Castro, M.L. Cruzat, S. Barros, J. Gironás, C. Oberli, M. Torres, C. Escauriaza and A. Cipriano are with the National Research Center for Integrated Natural Disaster Management CONICYT/FONDAP/15110017, Santiago, Chile (e-mail: daniel.pinto@cigiden.cl, lecastro@uc.cl, mlcruzat@uc.cl, sebarros@uc.cl).

A. Cipriano, C. Oberli and M. Torres are with the Electrical Engineering Department, Pontificia Universidad Católica de Chile, Santiago, Chile (e-mail: aciprian@ing.puc.cl, obe@ing.puc.cl, mtorrest@ing.puc.cl).

C. Escauriaza and J. Gironás are with the Hydraulic and Environmental Engineering Department, Pontificia Universidad Católica de Chile, Santiago, Chile (e-mail: jgironas@ing.puc.cl, cescauri@ing.puc.cl).

Environmental Satellite (GOES) network and adjusted with real-time precipitation data from local meteorological stations, which also provide temperature data.

A model of soil moisture utilizes rainfall and soil data with a potential evapotranspiration estimation to determine relevant variables for flash flood occurrence. Finally a Flash Flood Guidance (FFG) model gathers all this information to determine the amount of rainfall within a range of time in a specific zone needed for flash flood occurrence. Using the FFG, the decision makers can estimate the actual risk for a zone.

The Regional Center in Costa Rica is in charge of send general information to the national meteorological centers of the other countries, which adjust the information according to local data and give alerts to the local emergency agencies if necessary. The communication between centers is done by telephone, fax, email and internet. The general diagram of this system is presented in Fig. 1.

B. Aburrá Valley in Colombia

In the Aburrá valley the flash floods represent 35% of the natural disasters and cause 77% of deaths [7]. For these reasons, in 2008 the municipalities of the valley, with support from the NOAA, started the implementation of a FFEWS. One of the main features of this system is that it works together with the hydroelectric generators of the valley, which allows a better management of the dams in risk situations.

The system is operated by the Aburrá Valley Early Warning System (SIATA) that has deployed a network composed of 71 rain gauge stations, 7 meteorological stations (temperature, wind speed and wind direction), 8 water level sensors in the creeks, 7 live-streaming cameras and soil moisture sensors. All these networks are connected through GPRS to the SIATA

tower and transmit data in real-time. Moreover, the SIATA uses a radiometer for atmospheric observation and a weather radar.

The data processing made by the system follows a similar logic as the used by the CAFFG. The data from sensors is used to correct the radar and GOES precipitation estimation. With this information the FFG is estimated together with a quantitative precipitation estimate (QPE) and a risk analysis, which are sent to the dams operators. Today, a new forecasting model is under development, which was designed to achieve a better representation of the region.

The information bulletins and the warning alerts issued by the SIATA are sent to the Disaster Response and Prevention Office (DPAD), the Civil Defense, the Red Cross, the local government and to the population through different channels: an interactive webpage, social networks, email and instant messaging for authorities.

C. Landslide Warning System in Austria

The Early Landslide Detection and Warning System (ELDEWAS) [8] is an initiative that is being implemented in the region of Burgenland, Austria, under the European project INCA-CE, whose purpose is to improve the Integrated Nowcasting through Comprehensive Analysis (INCA) system of the Austrian Central Institute for Meteorology and Geodynamics.

ELDEWAS integrates dynamic data (e.g. precipitation, temperature and wind speed), with static data, (e.g. terrain and risk maps), as shown in Fig. 2. The system uses forecasting models to estimate the precipitation on a zone and incorporates this information to the risk analysis system. Furthermore, the system also uses the precipitation of the last hours to estimate soil moisture and saturation.

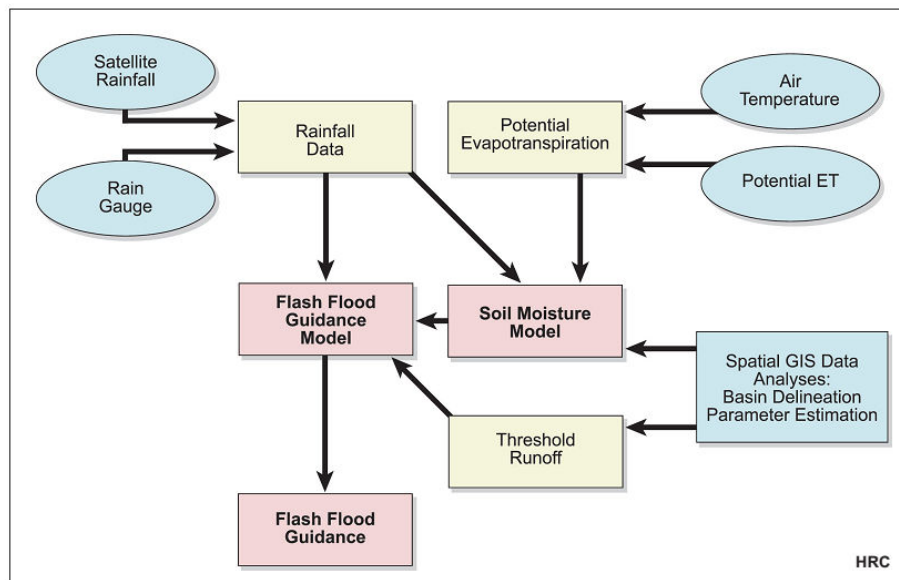

Fig. 1 Conceptual diagram of the CAFFG [5]

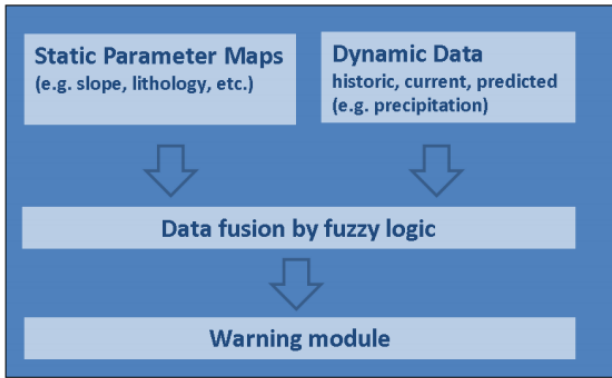

Fig. 2 Conceptual scheme of ELDEWAS [8]. Static and dynamic data are fused to be used by the warning module

One of the most relevant scientific features under development of ELDEWAS is the incorporation of fuzzy logic in the risk analysis. The advantage of employing this method is the possibility of use qualitative variables which allows the inclusion of variables that cannot be measured directly.

III. EARLY WARNING SYSTEMS ARCHITECTURE

In our previous work concerning different kinds of Early Warning Systems [9], we showed that these systems share a common structure. Despite the big differences between the phenomena that these EWS confront, all of them have a logic structure: relevant information is gathered, communicated by optimal means, assimilated and analyzed. Finally, the results are informed to the organizations concerned.

This structure logically responds to the problem of the Early Warning Systems, since it can accomplish the required needs: to know confidently what is happening in the moment, to comprehend it, to understand the risk and tell about it to the potential affected. Other systems can dispense some of these requirements as in some areas of scientific research, where there is not always need for instant data or to communicate the results immediately.

After reviewing different EWS, we found a common architecture composed of four subsystems (Fig. 3): Sensors,

Communication, Processing and Dissemination Subsystems. The Sensors Subsystem corresponds to the equipment used for monitoring the physical world and to quantify its variables of interest. The Communication Subsystem gathers the infrastructure and the protocols used to communicate the sensors and processing subsystems and the individual components of each one. The Processing Subsystem involves all the items concerning to the manipulation, storage, analysis and interpretation of the data and the use of it in the decision making process. Finally, the Dissemination Subsystem consists of the means and external elements necessary to send information to people.

A. Four Subsystems in the Flash Floods Case

In this section the four subsystems structure of the EWS are analyzed for the case of the FFEWS, using the previous systems reviewed as reference.

1. Sensors Subsystem

The Sensors Subsystem gathers the components needed to know how the hydrometeorological situation of the region is changing. To achieve this, different instruments for data recollection are needed (e.g. rain gauges, water level gauges, soil moisture sensors, wind gauges and temperature sensors). In some cases, remote sensing is also used for atmospheric observation through weather radars, satellite imagery and radiometers. In Table I, the sensors used in the three FFEWS previously reviewed are summarized.

2. Communications Subsystem

The Communication Subsystem is composed of the means for sending data from sensors to the processing center, and from there to authorities.

Generally in FFEWS, the data link from sensors is made through telemetry or mobile communication networks to a host with a reliable internet connection. For example, CAFFG and ELDEWAS use dedicated telemetry links but SIATA uses GPRS (one type of mobile communication technology) for data transmission.

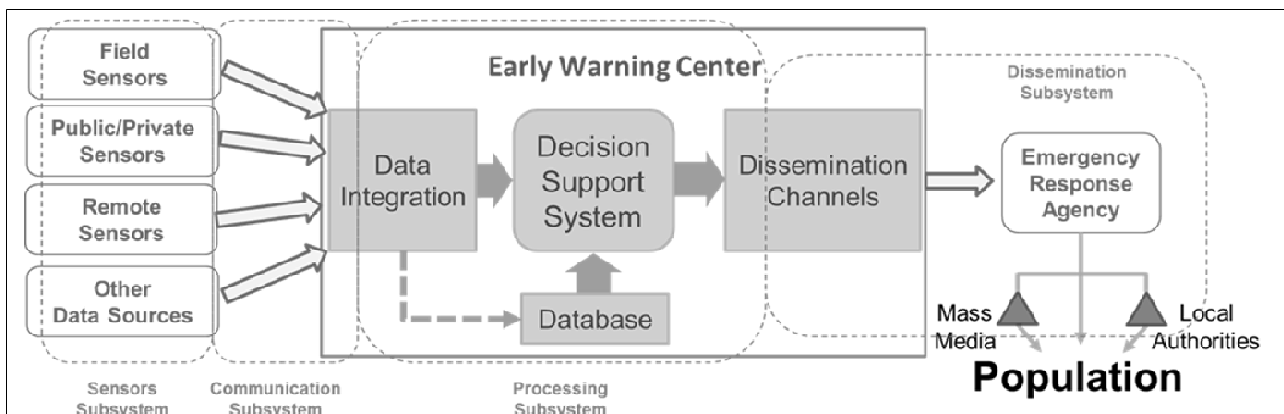

Fig. 3 Standard Early Warning System architecture

Sending data to authorities typically relies on internet or emails, or even use simpler means like fax or telephone. CAFFG, for example, uses these three alternatives unlike the SIATA which uses just internet based tools.

TABLE I
SENSORS UTILIZED BY THE FFEWS

Sensor	CAFFG	SIATA	ELDEWAS
Precipitation	YES	YES	YES
Water level	NO	YES	NO
Moisture	NO	YES	NO
Temperature	YES	YES	YES
Wind	NO	YES	YES
Radar	ONLY PANAMA	YES	NO
Satellite	YES	YES	NO
Atmosphere	NO	YES	NO

3. Processing Subsystem

The Processing Subsystem in FFEWS is composed of two elements: models and decision support systems. Models in FFEWS differ significantly from EWS for other natural hazards (e.g. tsunamis, volcanic eruptions) because they consider highly complex weather forecasting models. Generally, weather forecasting is the main tool for FFEWS due to the importance of precipitation in triggering flash floods and the amount of time with which the forecast can be made. Besides the forecast models, propagation and inundation models are used for risk estimation [10], [11].

The decision support systems analyze data from sensors and models to determine the level of danger that a flash flood event means for population. These systems usually use historic data as a reference for risk estimation and to generate hazard thresholds. A more detailed view of these systems will be presented in next section.

4. Dissemination Subsystem

The Dissemination Subsystem encompasses the means to communicate the danger of the situation to the people. Sometimes, this subsystem has two sides, because the FFEWS center and the authorities have separated tools to alert the population.

Depending on the characteristics of every basin or region, the need for a rapid alert system varies. Some systems use only informative websites with hourly or daily forecasts, like METEOALARM [12], while others use emails or social

networks as in the case of SIATA.

IV. DECISION SUPPORT SYSTEM

In simple terms, a Decision Support System (DSS) helps the operator’s decision making process. The DSS must consider all the relevant information about a problem, which can be too confusing for the operator, and make a decision based in the application of a rule set over this information to achieve an unbiased advice for the operator.

A. Components of a Decision Support System

A decision support system can be conceived to be composed of five main functional elements, as shown in Fig. 4, which are:

- 1) External Data: gathered through sensors, information systems or predictions, providing information about the actual or past values of variables or phenomena of interest.
- 2) Models: used to predict the behavior of phenomena from the current information about them.
- 3) Knowledge: gathered through experience or information, that allows understanding the possible effects of the observed and modeled phenomena.
- 4) Rule Set: specifying how the gathered information must be combined considering the models and knowledge to produce a set of suggested actions.
- 5) GUI: allowing the user to visualize a situation and the suggested actions, as well as to interact with the system under different decision scenarios.

B. Decision Support Systems in Flash Flood Early Warning Systems

The decision support systems used in Early Warning Systems may vary greatly depending on the phenomena they face. For example, the Tsunami EWS in Indonesia [13] uses data matching methodologies and model simulations to evaluate the danger of the tsunami impact. Earthquake EWS use inversion algorithms to determine the time for preparation or evacuation. In the case of Flash Flood EWS, the decision support systems work mainly with precipitation thresholds. Here we make a quick review of the DSS used by CAFFG and ELDEWAS.

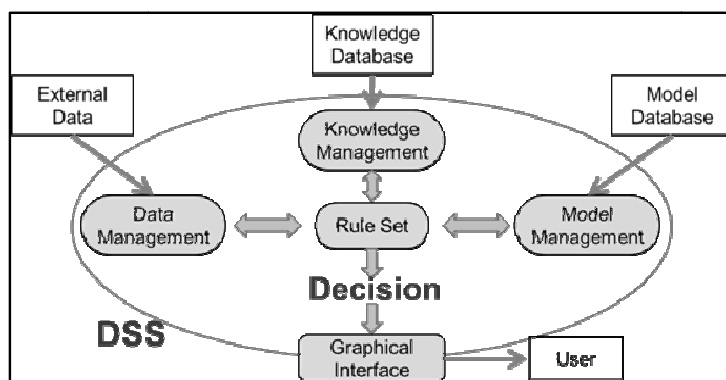

Fig. 4 Functional scheme of a Decision Support System

A widely used methodology to estimate the occurrence of a flash flood is the Flash Flood Guidance (FFG) [14]. Developed in the 70s in USA, the FFG determines the amount of rain within a time window necessary to start a flash flood. This evaluation strategy also requires knowledge about the basin soil moisture content and characteristics (e.g. type of soil and land covering). In the case of the CAFFG, rainfall data is used together with estimations of potential evapotranspiration as input for a soil moisture model. The output of this model is combined with runoff thresholds (defined by the characteristics of the basin) and rainfall data to determine the FFG of each basin.

A different and novel proposal for a decision support system for landslide is the one presented in ELDEWAS. This system utilizes fuzzy expert system to determine the chances that an event occurs using input variables that are hard to measure accurately. The advantage of using fuzzy expert systems in this situation is that through proper curve selection and calibration it is possible to use only a qualitative evaluation of variables instead of quantitative one. In this way, expert knowledge can supply the information necessary with only a rapid survey of the region.

Fuzzy expert systems [15] use rules of the type “If the inputs are A and B, then the output is C” to establish the relationship between all the variables, and make possible to estimate a group of the variables just with some information about the others. In the ELDEWAS case, for example, the slope and the angle of internal friction can predict the disposition: if both are very small, the disposition is also very small, but if both are just high (not the higher level), the disposition is just medium. A table with the different combination of the variables affecting disposition is shown in Fig. 5.

C. Proposal for a Flash Flood Early Warning Decision Support System

Here we present our current work in the development of the DSS for a pilot FFEWS in Santiago of Chile. This project is carried out together with other teams from the National Research Center for Integrated Natural Disaster Management (RCINDiM), initiative funded by the National Commission of Scientific and Technologic Research (CONICYT), in which four national universities and many Chilean and international partners participate.

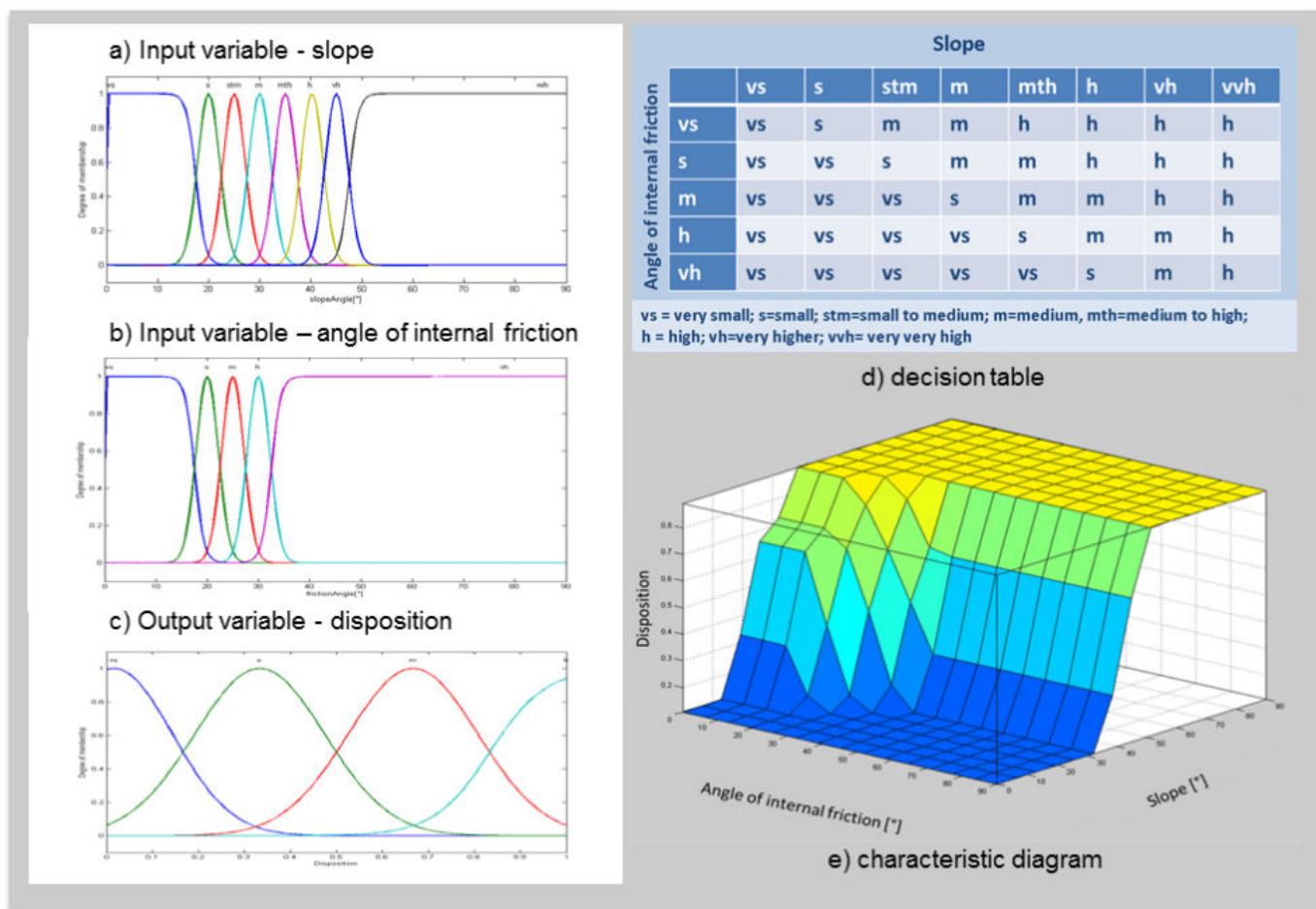

Fig. 5 Diagram of fuzzy expert systems from ELDEWAS [8]

1. General Proposal for the Pilot Flash Flood Early Warning System

One of the main tasks of the RCINDiM is the development of EWS prototypes for Chile. Following this, researchers proposed the development of a FFEWS at the Quebrada de Ramón (QR) drainage basin on the eastern side of the city of Santiago de Chile. A landslide at the neighboring Quebrada de Macul drainage basin that affected over 30.000 people back in 1993 triggered several mitigation actions on that basin, but not on other basins like the QR that pose similar threats to the population. For this reason, we chose QR basin as the location for our pilot Flash Flood and Landslide EWS (FFLEWS), but having in mind a three stages development: basic FFEWS, advanced FFEWS and complete FFLEWS.

Currently we are in the development of the first stage of the project. This basic FFEWS is composed of three elements, each one developed by a different team of the RCINDiM: a wireless sensor network, an empirical hydrological model and the decision support system. The next stage will also incorporate weather stations, more hydrometeorological models and satellite imagery, as depicted in Fig. 6. The satellite imagery will include GOES, MODIS, and TerraSAR-X observations, as well Tandem-X DEM relief maps, with a similar multiscale flood monitoring methodology and workflow as proposed in [16].

The wireless sensor network (WSN) is composed of a group of low-power nodes equipped with temperature and humidity sensors [17], [18]. These nodes communicate wirelessly with each other, thus passing the sensed data hop by hop to a sink node. The sink node has Internet access over mobile communications networks and posts the sensed data to a database in the Cloud. The sensor network has the capacity of

adapting the path from each node to the sink in case of intermediate node failure, enhancing the reliability of the network. The provision of sink node redundancy is ongoing work. Field experience with (WSN) for hydrometeorological monitoring can be found e. g. in [19]-[22]. The first five nodes of the sensor network for the QR basin prototype FFEWS were installed on site in May of 2014, closeby to the Santiago city edge and at altitudes between 800 and 1000 meters above sea level (masl, Fig. 7). The nodes were developed in-house and are currently being field-tested. The variables measured and reported in real time to a database on the Internet so far are humidity and air temperature. Integration of further sensors such as soil moisture and rainfall is ongoing work. Fifteen additional nodes are planned to be deployed during 2014 along the southern ridgeline of QR. This way, a transect line of sensors reaching altitudes of about 3000 masl will allow for real-time inference of the zero-degree isothermal altitude, whose knowledge is a key input to the FFEWS.

The empirical model [23]-[25] is based on a study of historical data from weather stations and water level gauges from the QR basin and other related positions of the region. Using Principal Component Analysis (PCA), results have shown that a good prediction of the QR basin overflow can be made combining the temperature of the last two days and the amount of rainfall of the last two weeks.

In the current stage of development of the project, the system depends on the weather forecast made by the National Meteorological Direction (DMC), research partner of the RCINDiM. Nevertheless, the system will in addition use weather stations and rain gauges, together with the wireless sensor network for precipitation measurements.

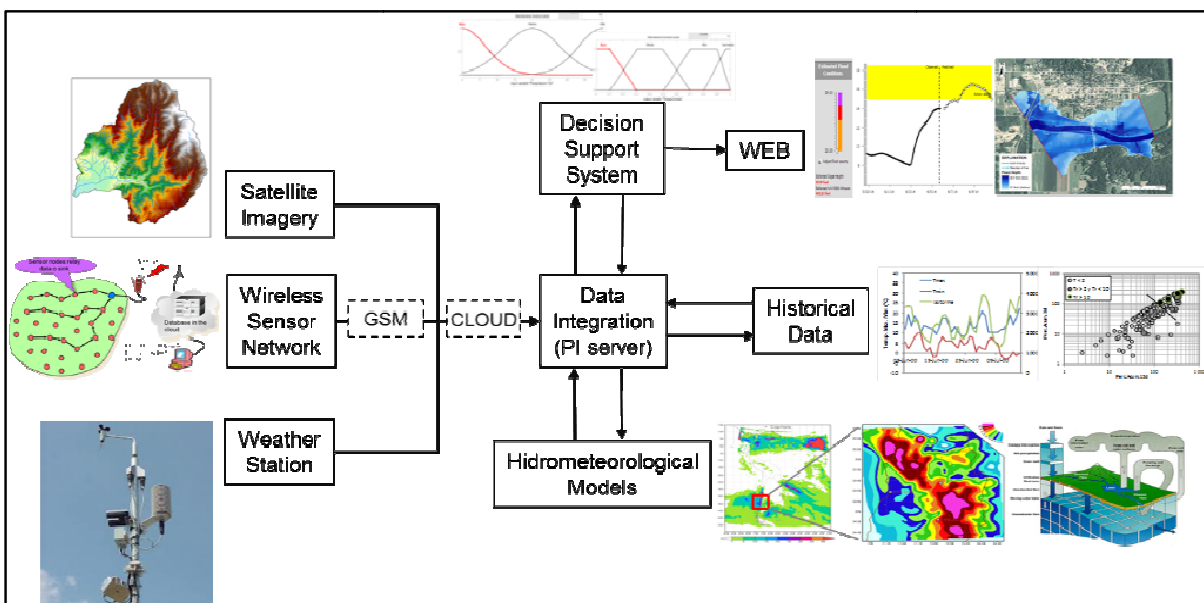

Fig. 6 Diagram of the pilot FFEWS for Quebrada de Ramón basin



Fig. 7 Two prototype nodes of the wireless sensor network deployed in the Quebrada de Ramón basin for the proposed FFEWS prototype. The skyline of the city of Santiago de Chile can be seen on (b)

2. Fuzzy Expert System Based Decision Support System

The proposal for the FFEWS decision support system of this project is based on fuzzy expert systems. The main idea is to make a risk estimation using information from the empirical model and the fuzzy expert systems so that the whole system has a more reliable estimation capacity. In Fig. 8 a diagram of the proposed DSS is shown.

Despite that the thresholds of both decision systems are made with the same historical data, response of every one can be different in an important level. This is because fuzzy expert systems have the property of giving a more adaptable interpretation to the data, due to its fuzzy nature. But this also has to be complemented with proper calibration, including selection of curve shapes and quantity of fuzzy groups, which is exactly the target of this stage of our work.

The comparison and decision block will inform of the reliability of the risk estimation, based on the coherence of the outputs of the empirical model and the fuzzy expert blocks and also in the accuracy of the weather forecast. In case that both estimation blocks agree in the level of risk and the weather forecast is consistent with data from field sensors, the reliability of the whole system is high. On the contrary, if the estimation blocks do not agree, the system will wait until a new group of input data arrives. Since the estimations can be made many hours ahead, this wait will not be critical. Finally, in the case that the forecast and the sensor data do not have

consistency, a rapid correction will be made by weather models that will be developed in the second stage of the general project.

The final output of the decision support system will be a qualitative risk level and a non-exceedance probability that is transferred then to the population and authorities. As depicted in Fig. 6, the last part of the proposed FFEWS is a webpage which gathers all the information and give it to the people. In the first stage, the risk will be communicated just through the outputs of the DSS, but in the final stage, with the incorporation of more complex models, the webpage will also show simulations of inundations maps, to help not just in the evacuation, but in the planning of the response and help given by authorities to affected people after the events occurs.

V. CONCLUSION

In this paper we present our work in three sections, two related with our previous work, the analysis of other EWS, and the first step of the pilot FFEWS that we are developing together with other research teams of RCINDiM. The last section summarizes our proposal for decision support systems for the FFEWS.

Flash Floods and Landslide Early Warning Systems have a similar structure since both need to keep a permanent vigilance of weather conditions, mainly in mountainous regions. Three projects were reviewed: the Central America Flash Flood Guidance, the SIATA from Colombia and the Early Landslide Detection and Warning System in Austria. A rapid comparison between these systems confirms that they share a common structure.

Early Warning Systems also share a common structure, based in four subsystems: Sensors, Communication, Processing and Dissemination. This structure presents itself as the logic response to the problem of the Early Warning Systems, since it can accomplish the needs they require: to know confidently what is happening in the moment, to comprehend it, to understand the risk and tell about it to the potential affected.

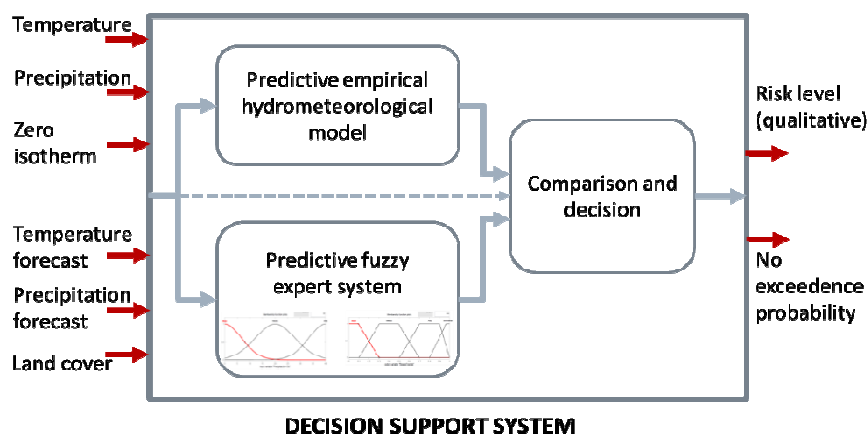

Fig. 8 Diagram of the proposed Decision Support System for the FFEWS

A key element of the EWS is the Decision Support System, which literally helps operators to make decisions, combining expert knowledge, data and models and following a rule set specially developed for the system. The Flash Flood EWS use DSS based mainly on precipitation thresholds, which can be sharp or fuzzy. This last modality allows a more flexible response in front of different situations.

Our proposal for the pilot FFEWS uses data gathered through a wireless sensor network deployed in the Quebrada de Ramon basin and weather forecast to make risk estimations with two systems: an empirical model and a fuzzy expert system. The output of both is compared to determine the level of reliability of the estimation.

The next step in the development of the pilot FFEWS is to calibrate both empirical model and fuzzy expert system with historical data so they become able to be used with the real system. After this, the second stage of the project will start to integrate more complex models, inundation simulations and other data source as satellite imagery.

ACKNOWLEDGMENT

This work was conducted under the supervision of the National Research Center for Integrated Natural Disaster Management (RCINDIM) CONICYT/FONDAP/15110017 (Centro Nacional de Investigación para la Gestión Integrada de Desastres Naturales, CIGIDEN). The RCINDIM was established by four national universities: Pontificia Universidad Católica de Chile, Universidad Católica del Norte, Universidad Federico Santa María and Universidad Andrés Bello. Funding was provided by the Chile-based National Commission for Scientific and Technological Research (CONICYT).

REFERENCES

- [1] B. Wisner, P. Blaikie, T. Cannon, and I. Davis, *Risk: natural hazards, people's vulnerability and disasters*. London: Routledge, 2004.
- [2] S.L. Cutter, and C. Emrich, "Are natural hazards and disaster losses in the US increasing?," *Eos, Trans. American Geophysical Union*, vol. 86, no. 41, pp. 381-389, 2005.
- [3] W. Hanka, J. Saul, B. Weber, J. Becker, and P. Harjadi, "Real-time earthquake monitoring for tsunami warning in the Indian Ocean and beyond," *Nat. Hazards Earth Syst. Sci.*, vol. 10, pp. 2611-2622, 2010.
- [4] World Meteorological Organization, "Natural Hazard," online article http://www.wmo.int/pages/themes/hazards/index_en.html Accessed July 2014.
- [5] C.D. Hill, F. Verjee, and C. Barrett, *Flash Flood Early Warning System Reference Guide*. USA: University Corporation for Atmospheric Research, 2010.
- [6] World Meteorological Organization "Flash Flood Guidance System (FFGS)," Paper for the CBS Management Group, World Meteorological Organization, Commission for Basic Systems Management Group, seventh session, Geneva, Switzerland, June 2007.
- [7] E. Aristizábal, M.F. Gamboa, and F.J. Leoz, "Early Warning System for rainfall-induced landslides in the Aburrá valley, Colombia," *Revista EIA*, no 13, pp. 155-169, July 2010.
- [8] O. Krol, and T. Bernard "ELDEWAS - Online early warning system for landslide detection by means of dynamic weather nowcasts and knowledge based assessment," in *International Environmental Modelling and Software Society (iEMSs) 2012 International Congress on Environmental Modelling and Software Managing Resources of a Limited Planet: Pathways and Visions under Uncertainty, Sixth Biennial Meeting*, Leipzig, Germany, pp. 212-219.
- [9] D. Pinto, and A. Cipriano "Tsunami Early Warning System architecture based on automation technologies," in *ICT-DM 2014: The First IEEE International Conference on Information and Communication Technologies for Disaster Management*, Algiers, March 2014. To be published.
- [10] F.N. Correia, F.C. Rego, M.D.G. Saraiva, and I. Ramos, "Coupling GIS with hydrologic and hydraulic flood modelling," *Water Resour. Manage.*, vol. 12, no. 3, pp. 229-249, 1998.
- [11] Y. Lian, I. Chan, J. Singh, M. Demissie, V. Knapp, and H. Xie, "Coupling of hydrologic and hydraulic models for the Illinois River Basin," *J. Hydrol.*, vol. 344, no. 3, pp. 210-222, 2007.
- [12] M. Staudinger, "METEOALARM-EF, Final Report." March, 2011. Available at http://ec.europa.eu/echo/civil_protection/civil/prote/pdfdocs/meteoalarm_final_report_en.pdf
- [13] J. Behrens, A. Androsov, A.Y. Babeyko, S. Harig, F. Klaschka, and L. Mentrup "A new multi-sensor approach to simulation assisted tsunami early warning," *Nat. Hazards Earth Syst. Sci.* vol. 10, no. 6, pp. 1085-1100, 2010.
- [14] K.P. Georgakakos, "Analytical results for operational flash flood guidance," *J. Hydrol.*, vol. 317, no. 1, pp. 81-103, 2006.
- [15] T. Terano, K. Asai, M. Sugeno, and C. Aschmann, *Applied fuzzy systems*. San Diego, CA: Academic Press Professional, Inc., 1994.
- [16] S. Martinis, A. Twele, C. Strobl, J. Kersten, and E. Stein, "A Multi-Scale Flood Monitoring System Based on Fully Automatic MODIS and TerraSAR-X Processing Chains," *Remote Sens.*, vol. 5, no. 11, pp. 5598-5619, 2013.
- [17] H. Karl and A. Willig, *Protocols and Architectures for Wireless Sensor Networks*. West Sussex: John Wiley & Sons, 2005.
- [18] K. Sohraby, D. Minoli, and T. Znati, *Wireless Sensor Networks: Technology, Protocols, and Applications*. New Jersey: Wiley-Interscience, 2007.
- [19] G. Barrenetxea, F. Ingelrest, G. Schaefer, M. Vetterli, O. Couach, and M. Parlange, "Sensorscope: Out-of-the-box environmental monitoring," in *Information Processing in Sensor Networks, 2008. IPSN '08. International Conference on*, St. Louis, MO, Apr. 2008, pp. 332-343.
- [20] F. Ingelrest, G. Barrenetxea, G. Schaefer, M. Vetterli, O. Couach, and M. Parlange, "Sensorscope: Application-specific sensor network for environmental monitoring," *ACM Trans. Sen. Netw.*, vol. 6, no. 2, pp. 17:1-17:32, Mar. 2010.
- [21] S. Simoni, S. Padoan, D. F. Nadeau, M. Diebold, A. Porporato, G. Barrenetxea, F. Ingelrest, M. Vetterli, and M. B. Parlange, "Hydrologic response of an alpine watershed: Application of a meteorological wireless sensor network to understand streamflow generation," *Water Resour. Res.*, vol. 47, no. 10, 2011.
- [22] B. Kerkez, S. D. Glaser, R. C. Bales, and M. W. Meadows, "Design and performance of a wireless sensor network for catchment-scale snow and soil moisture measurements," *Water Resour. Res.*, vol. 48, no. 9, 2012.
- [23] M. Berti, M.L.V. Martina, S. Franceschini, S. Pignone, A. Simoni, M. Pizziolo, "Probabilistic rainfall thresholds for landslide occurrence using a Bayesian approach," *J. Geophys. Res. Earth Surf. (2003-2012)*, vol. 117, no. F4, 2012.
- [24] V. Montesarchio, E. Ridolfi, F. Russo, F. Napolitano, "Rainfall threshold definition using an entropy decision approach and radar data," *Nat. Hazards Earth Syst. Sci.*, vol. 11, no. 7, pp. 2061-2074, 2011.
- [25] S.A. Sepúlveda, C. Padilla, "Rain-induced debris and mudflow triggering factors assessment in the Santiago cordillera foothills, Central Chile," *Nat. Hazards*, vol. 47, no. 2, pp. 201-215, 2008.