

Protection Plan of Medium Voltage Distribution Network in Tunisia

S. Chebbi, A. Meddeb

Abstract—The distribution networks are often exposed to harmful incidents which can halt the electricity supply of the customer. In this context, we studied a real case of a critical zone of the Tunisian network which is currently characterized by the dysfunction of its plan of protection. In this paper, we were interested in the harmonization of the protection plan settings in order to ensure a perfect selectivity and a better continuity of service on the whole of the network.

Keywords—Distribution network Gabes-Tunisia, NEPLAN©DACH, protection plan settings, selectivity.

I. INTRODUCTION

WORLDWIDE, electricity became a vital resource. We are unable to work without electricity in the modern societies and an interruption of power supply can cause the complete paralysis of the country. Consequently, the recourse to install the automats and the efficient protective relays ensuring the proper functioning of the electric system as well as the security of citizens is vital.

Therefore, the distribution networks of power electric must be equipped with an adequate protections means to guarantee a quality of service to the electric power consumer to face the severe disturbances and to limit their consequences [1].

Unfortunately, we note that although the protection plan is installed in the distribution networks and normally the stability as well as the reliability of the electric system, we note that in spite of all these precautions, serious power outages can arise often following a short-circuits [2].

To study these problems, we choose the actual 33 kV and 15 kV distribution networks of Gabes; they are located in the South-East of the Tunisian network which is shown in the Appendix. Thus, 33 kV network has an effectively earthed neutral (MALT) according to North American standard. As for 15 kV network is earthed via high impedance by European standard [3]. Thus, the grounding system has a considerable amount of influence on the nature and level of disturbances. Furthermore, this network is choosing in view of vulnerability protection plan. In order to overcome this problem, a selectivity study is crucial to determine the ability of a relay to maintain Continuity of supply by disconnecting the minimum section of the network necessary to isolate the fault.

Note that in the distribution network of medium voltage, the chronometric selectivity and the logical selectivity can ensure

a conscientious protection while for low-voltage an ampere metric selectivity is sufficient [4], [5].

II. DESCRIPTION OF THE NETWORK STUDY

The medium voltage (MV) distribution network of Gabes is coupled to the HV busbar via five 40MVA 150/33 kV transformers (33kV network), that feeding four transformers on the 15kV network. Their characteristics are summarized in Table I. These substations are connected to medium voltage loads through overhead power lines and underground cables.

All transformers earthed via a neutral point reactance (BNP), because the transformers connection are wye-delta (Ynd11). Thus, the earthing system has an important role in a distribution network and affects the protection schemes [6].

In both network 33 kV and 15 kV, the distribution feeder protection begins at each substation with feeder breaker or recloser. In this network the recloser is equipped with an inverse and definite time overcurrent relay which detects fault and orders the trip of breaker. Then, after a preset delay, it recloses the breaker.

TABLE I
CHARACTERISTICS OF POWER TRANSFORMERS

Substation	Apparent Power (MVA)	U_{cc} (%)	Coupling	Grounding
33kV network				
Gannouch1	40	11.72	Ynd11	BPN
Gannouch2	40	12.02	Ynd11	BPN
Gannouch3	40	12.02	Ynd11	BPN
South Gabes1	40	12	Ynd11	BPN
South Gabes2	40	12	Ynd11	BPN
15kV network				
Gabes 1	40	10.55	Ynd11	BPN
Gabes 2	40	10.04	Ynd11	BPN
Nahal1	40	10.55	Ynd11	BPN
Nahal2	40	10.04	Ynd11	BPN

III. DISTRIBUTION MEDIUM VOLTAGE NETWORK 33kV

The 33 kV network is composed of two 33/150 kV substations, Ghannouch and South-Gabes. When one of transformer will out service, the second will be supply customers with power, in order to avoid a failure.

A. Ghannouch Substation

We study in the first time, Ghannouch substation, medium voltage network, which is connected to a high voltage transmission network through “step down” transformers (not shown in Fig. 1). Three 150/33 kV transformers are coupled on the busbar feeding thirteen MV feeders. The single line diagram of this substation is depicted in Fig. 1.

S. Chebbi and A. Meddeb are with Research Laboratory of Technologies of Information and Communication & Electrical Engineering (LaTICE) at the University of Tunis, Tunisia (e-mail: souad.chebbi@yahoo.com, meddebasma@yahoo.fr).

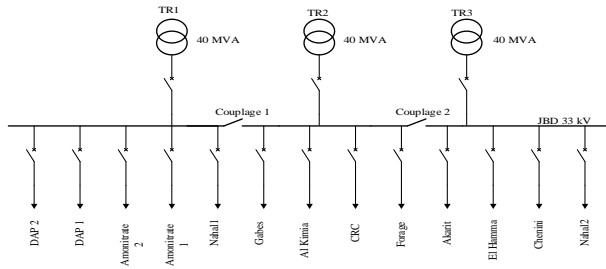

Fig. 1 Single line diagram of Ghannouch substation

1. Protection Plan of Ghannouch Substation

In the actual medium voltage network, protective devices, as well as, overcurrent protection, recloser, sectionalisers and fuses, are installed to mitigate safety hazards to the public, prevent and minimize damage to equipment, and improve service reliability by clearing fault at time. All feeders are equipped with time overcurrent relays as MICOMP122 and MICOMP142 [7]. The HV network protection serves as backup protection for 33kV.

On the other hand, the transformers are also equipped with an internal protection, Buchholz relay, differential protection and tank-ground protection [8], to avoid thermal heating caused by overloading [9]. We also note that the protection schemes depend on earthing methods because it has a direct influence on the protection systems of the transformers, lines and the cables. They serve to limit the earth fault current and improve fault detection in a power system [10].

2. Relay Protection Settings

The current settings of the relay are based on short circuit calculation and the time grading is done in a way that selectivity is satisfied. Appropriate protection settings are found by calculating worst-case fault situations.

The definite and inverse time overcurrent protection schemes have been evaluated for classical time grading of 300ms for the successive feeder relays in order to guarantee selectivity. For the settings of the definite overcurrent relay are based on the time and the value of current of threshold for which protections can tripped. While for the settings of the inverse time overcurrent relay, the characteristics of relay are based on CEI standard [11], which is expressed by (1):

$$t = \frac{T \times 1.35}{\left(\frac{I}{I_s}\right) - 1} \quad (1)$$

where: I_s : pick up current of relay; I : fault current seen by relay; T : time multiplier setting of relay which is between 0.025 and 1.5.

1. Simulation Results

In order to analyze the influence of short-circuit on various protection schemes in the distribution network, detailed simulation studies are required. Thus the results of simulations are implemented in NEPLAN©DACH [12].

The protection schemes settings are applied on the investigated network to evaluate the impact of short-circuit of network protection. Thus, in this distribution networks 70 to 80 % of the faults are single-phase short-circuit [13]. This is the reason why only this type of fault is simulated. Scenario case as single-phase fault downstream each feeder is studied.

The fault location, the triggered relay and their corresponding fault clearing times are presented for this scenario case on Tables II and III.

Indeed, the relay setting must be adjusted with a lower value than the minimal current of short-circuit of the investigated section and higher than the maximum value of the current due to the downstream fault location. Furthermore, the settings relay protection of MV zone must take account of protection schemes of HV zone. Tables II and III depict the simulation results for feeders Nahal2, El hamma and El kimia. For the others feeders, the protection selectivity is satisfied and the protection schemes installed are adequate under fault situation.

TABLE II
SETTING RELAYS OF GANNOUCH SUBSTATION

Relay	TC		I_c (kA)		Setting	
	Ip/Is	Class	Max	Min	Threshold1	Threshold2
Nahal 2						
P1	300/5		300	1.475	1.083	1.32× DT 1×In 3.33×In
P2	150/5	5P20	150	1.403	1.220	1s×DT 1×In 0.03×VI
P3	300/5		300	1.245	1.083	1s×DT 1×In 0.03×VI 1×In
El hamma						
P1	300/5		300	1.745	1.335	1s×DT 1×In 0.08×VI 1×In
P2	150/5	5P20	150	1.665	1.449	1s×DT 1×In 0.03×VI 1×In
P3	250/5		250	1.535	1.335	1s×DT 1×In 0.03×VI 1×In
El kimia						
P1	300/5	5P20	300	9.750	7.740	1.15× DT 1×In 0.4s× VI 25×In
P2	300/5		300	8.896	7.740	0.5× DT 1×In 25×In

TABLE III
PROTECTION SELECTIVITY GANNOUCH SUBSTATION

Downstream relay	Active relay	Tripping Time	ΔT	Selectivity
Nahal				
P2	P2-P1	0.06s-0.51s	0.45s	yes
P1	P1	0.51s	--	no
El hamma				
P2	P2-P1	0.05s-0.036s	0.31s	yes
P1	P1-P _{TR}	0.34s-0.88s	0.54s	yes
El kimia				
P2	P2-P1-P _{TR}	0.02s-0.41s-0.9s	P1/P2 :0.39s	yes

As aforementioned, simulation of short-circuit shows that time grading of relays show the exactitude of the suggested settings and inverse time relay activate faster than definite time. Except for Nahal 2 feeder which have an insensitive with the fault downstream the relay P2 and P3, installed throughout the overhead line. This is justified by the fact that Nahal2

feeder is characterized by great length of line (36884m) and low value of short-circuits current. In this case, the hazards of tripping the backup protection increase and can leading to the loss of energy of Ghannouch substation.

B. South-Gabes Substation

There are two substations, South-Gabes1 and South-Gabes2, owned by South-Gabes substation. Five MV feeders are connected on the 33kV busbar. These substations have similar type of protection relays as Ghannouch substation.

The protection schemes are installed as a protective measure to prevent dangerous short-circuit. The protection plan diagram of South-Gabes substation is shown in Fig. 2.

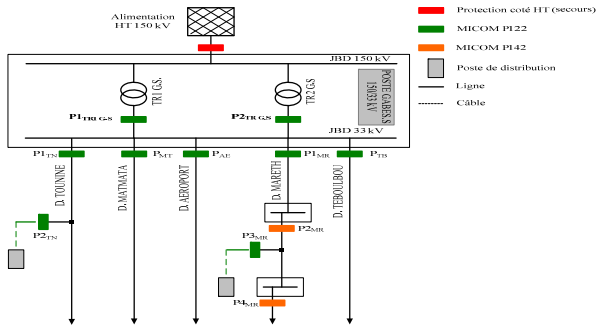

Fig. 2 Protection plan of South-Gabes substation

1. Relay Protection Settings

The similar scenarios as Ghannouch substation are simulated, the setting of each relays is verified. The result is resumed at Table IV.

TABLE IV
SETTING RELAYS OF SOUTH-GABES SUBSTATION

Relay	TC		In (A)	I _{cc} (kA)		Setting	
	Ip/Is	Class		Max	Min	Threshold1	Threshold2
Mereth							
P1	400/5	5P20	400	1.460	0.597	0.044×VI 1×In	--
P2	300/5		300	0.786	0.684	0.05×VI 1×In	0.33s×DT
P3	150/5		150	0.676	0.588	0.06×VI 1×In	0s×DT 3.73×In
P4	150/5		150	0.668	0.597	0.06×VI 1×In	0s×DT 3.85×In
Tounine							
P1	400/5	5P20	400	1.454	0.578	1s×DT 1×In	0.03×VI 1×In
P2	150/5		150	0.664	0.578	1s×DT 1×In	0.03×VI 1×In
P	400/5	5P20	400	2.742	0.550	1s×DT 1×In	0.03×VI 1×In
Aeroport							
P	400/5	5P20	400	2.308	1.900	0.124×VI 1×In	0.3s×DT 2.77×In
TR1 _{GS}							
P _s	800/5	5P20	700	4.546	3.955	--	0.9s×DT 1×In

2. Simulation Results

By using these results in the study of efficiency relays selectivity, we can remark that protections of transformers and

Mereth feeder, remain insensitive to the fault located downstream the relays P2_{TN}, P3_{MR} and P4_{MR}. We must emphasize that the low value of short-circuit current and long cable (53654m for overhead lines and 1400 m for the underground lines) are the major cause of malfunction of the relays, similarly, for feeder Tounine. As a result the HV backup protection will be tripped. Nevertheless, the risk of loss of supply HV substation can increase.

VI. DISTRIBUTION MEDIUM VOLTAGE NETWORK 15kV

The 15 kV network has impedance earthed neutral. It is composed of two substations Gabes (42830 kVA) and Nahal (21503 kVA). These substations are equipped with switchgear for 33kV and 15 kV, 33/15 kV transformation equipment and an overcurrent protection schemes. There are five underground cable and only one overhead power line connected to the busbar 15 kV. Ten MV feeders are supplied by this network.

A. Gabes Substation

Fig. 3 shows the overcurrent scheme applied in Gabes substation. Each feeder is equipped with overcurrent relays. This device should be coordinated upstream with the protection of high voltage transformer (Pp1TRG and Pp2TRG) and with downstream relays (Ps1TRG and Ps2TRG). Downstream devices are reclosers. All of the protective devices placed in series should coordinate on a time-current basis with each other in order to minimize the impact of an outage due to a fault. Additionally, backup protection is provided using overcurrent protection located upstream 33kV busbar.

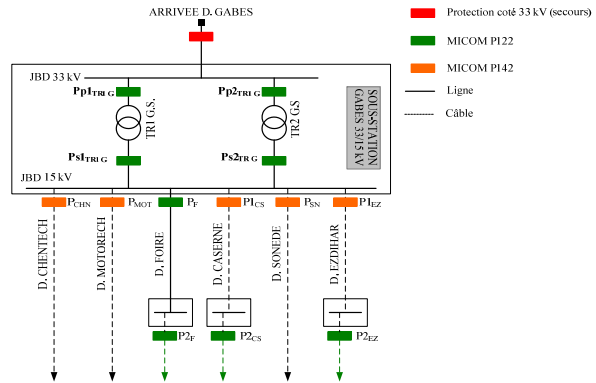

Fig. 3 Protection plan of Gabes substation

1. Relay Protection Setting

Likewise for 15kV network, to understand the impact of short-circuit the same scenarios as 33kV network are simulated to verify the actual settings of relays and to what extend the performance of selectivity. Tables V and VI specifies settings and selectivity of relays.

2. Simulation Results

Based on the settings made in the Table V, we can also recognize that the selectivity is respected for all feeders except

for feeder Foire. Thus, protections of the power transformers do not tripped at time during the fault located downstream P2F. This is justified by the fact that this feeder is characterized by the long overhead lines (3165 m) as compared with the rest of feeder which are having only an underground cable. Therefore, we can conclude that in case of overhead lines the protection reliability is expected to decrease.

TABLE V
SETTING RELAYS OF GABES SUBSTATION

R	TC		In (A)	$I_{cc} (kA)$		Setting	
	Ip/Is	Class		Max	Min	Threshold1	Threshold2
Ezdihar							
P1	400/5	5P20	400	5.670	2.027	$0.12 \times VI$ $1 \times In$	$0.3s \times DT$ $4 \times In$
P2	200/5		200	2.330	2.027	$0.063 \times VI$ $1 \times In$	$0s \times DT$ $4 \times In$
Foire							
P1	400/5	5P20	400	4.729	1.725	$0.12 \times VI$ $1 \times In$	$0.3s \times DT$ $4 \times In$
P2	150/5		150	1.982	1.725	$0.063 \times VI$ $1 \times In$	$0s \times DT$ $4 \times In$
Motorech							
P	400/5	5P20	400	4.321	3.760	$1s \times DT$ $1 \times In$	$0.03 \times VI$ $1 \times In$
TR1 _{SG}							
P _s	600/5	5P20	578	3.307	0.859	$0.04 \times VI$ $1 \times In$	$5.84s \times DT$ $1.75 \times In$

TABLE VI
SELECTIVITY RELAYS OF GABES SUBSTATION

Downstream Zone	Active Relay	Tripping Time	ΔT	Selectivity
Ezdihar				
P2	P2-P1-P _{TR}	0s-0.3s-0.6s	0.3s	Yes
P1	P1-P _{TR}	0.3s-0.6s	0.3s	Yes
Foire				
P2	P2-P1	0s-0.3s	0.3s	No
P1	P1-P _{TR}	0.3s-0.6s	0.3s	Yes
Caserme				
P2	P2-P1-P _{TR}	0s-0.3s-0.6s	0.3s	Yes
P1	P1-P _{TR}	0.3s-0.6s	0.3s	Yes
Sonede				
P1	P-P _{TR}	0.05s-0.6s	0.55s	Yes
Motorech				
P1	P-P _{TR}	0.05s-0.6s	0.55s	Yes
TR1 _{SG}				
Bus 33kV	P _{TR} -P _G	0.6s-0.9s	0.3s	Yes

B. Nahal Substation

There are four simple feeders connected to Nahal substation. It has her own 15 kV busbar, which is fed by the feeder Nahal1 via two MV/MV power transformers. The backup protection is located at the beginning of 33kV busbar. Each feeder is equipped with an overcurrent relay which must be coordinate with the overcurrent protection on the 33kV/15kV transformers. The protection plan of Nahal Substation is shown in Fig. 4.

1. Simulation Results

In order to evaluate the settings relay, a single-phase fault, at each line, is simulated. Both Tables VII and VIII show how

the proposed setting relay impacted the selectivity of protection. Once the outcomes are identified, we conclude that the settings relays of the all feeders ensure the best selectivity in this substation.

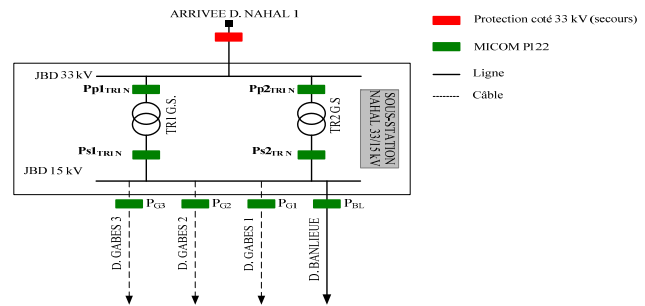

Fig. 4 Protection plan of Nahal substation

TABLE VII
SETTING RELAYS OF NAHAL SUBSTATION

Relay	TC		In (A)	$I_{cc} (kA)$		Setting	
	Ip/Is	Class		Max	Min	Threshold1	Threshold2
Departure Gabes1							
P	300/5	5P20	300	2.606	2.267	$0.114 \times VI$ $1 \times In$	$0s \times DT$ $8.65 \times In$
Feeder Gabes2							
P	300/5	5P20	300	4.949	4.306	$0.061 \times VI$ $1 \times In$	$0s \times DT$ $3.85 \times In$
Feeder Gabes3							
P	300/5	5P20	300	5.011	4.360	$0.62 \times VI$ $1 \times In$	$0s \times DT$ $3.85 \times In$
TR1 _{SN}							
P _s	600/5	5P20	578	3.773	3.283	$0.04 \times VI$ $1 \times In$	$0.28s \times DT$ $1.93 \times In$
TR2 _{SN}							
P _s	600/5	5P20	578	3.601	3.133	$0.04 \times VI$ $1 \times In$	$0.28s \times DT$ $1.93 \times In$

TABLE VIII
SELECTIVITY RELAYS OF NAHAL SUBSTATION

Downstream Zone	Active Relay	Tripping Time	ΔT	Selectivity
Gages2				
P	P-P _{TRSN} -P1 _N -P _{TRGH}	0s-0.3s-0.6s-0.9s	0.3s	Yes
Gages 1				
P	P-P _{TRSN} -P1 _N -P _{TRGH}	0s-0.3s-0.6s-0.9s	0.3s	Yes

V. CONCLUSION

The relay settings of network distribution are an important topic in a context where relay selectivity must be satisfied. The study thus presented based on the simulation of the single short-circuit affecting the Gabes network verify the inadequacy of protection schemes in some feeders, Nahal 2 derived from Ghannouch substation, Mereth and Tounine owned by South-Gabes substation and feeder Foire from Gabes substation. We can conclude that the dysfunction of transformer relay is due to an overload condition that causes an overheating in the power transformer. For this reason, it is necessary to include protection against transformer overload.

Lastly, we propose the revise of earthing system used in this network to avoid unnecessary outage of the whole system.

APPENDIX



Fig. 5 Distribution networks of Gabes

REFERENCES

- [1] J. Keller and B. Kroposki, "Understanding fault characteristics of inverter-based distributed energy resources," Technical report, January 2010.
- [2] M. Murali, P. Sharath Kumar and K. Vijetha, "Adaptive relaying of radial distribution system with distributed generation," IJECE, June 2013.
- [3] H.Khaled, "MV network with an effectively earthed neutral (MALT)," Technical report of power distribution Tunisian, 2010.
- [4] F. Malone and P.D. Doyle, "Evaluation of alternative backup protection schemes on a 66KV distribution network," ESB International, Ireland, 2010.
- [5] D. Shipp and F. Angelini, "Characteristics of different power systems neutral grounding techniques," Technical Conference, IEEE, 1988.
- [6] D. Pala, C. Torrnnelli and G. Proserpio, "An adaptive agent-based protection scheme for radial distribution network based on IEC 61850 and IEC 61499," CIRED, May 2012.
- [7] B.Z. Zaremski, "The advancement of adaptive relaying in power systems protection," Master of Science, Virginia Polytechnic Institute, April 2012.
- [8] E. Ebrahimi, G. B. Gharehpetian and J. Milimonfared, "A novel scheme to protect distribution networks in presence of inverter-based Distributed generation," CREPQ, Spain, March, 2012.
- [9] R. Hunt and M. L. Giordano, "Thermal overload protection of power transformers," Conference Georgia Tech, 2005.
- [10] J. Wan, "Nodal load estimation for electric power distribution systems," Thesis, Drexel Univ, July 2003.
- [11] P. Janssen, "Monitoring, protection and fault location in power distribution networks using system-wide measurements," Ph.D in Engineering Sciences, Bruxel Univ, 2013.
- [12] X. Yu, "Distribution system reliability enhancement," Thesis, Georgia Institute of technology, August 2011.
- [13] M. Zellagui, "Protection schemes of 30 kV and 10 kV network," Thesis, Algeria Univ, July 2010.