

Performance Evaluation of an Efficient Asynchronous Protocol for WDM Ring MANs

Peristera A. Baziana

Abstract—The idea of the asynchronous transmission in wavelength division multiplexing (WDM) ring MANs is studied in this paper. Especially, we present an efficient access technique to coordinate the collisions-free transmission of the variable sizes of IP traffic in WDM ring core networks. Each node is equipped with a tunable transmitter and a tunable receiver. In this way, all the wavelengths are exploited for both transmission and reception. In order to evaluate the performance measures of average throughput, queuing delay and packet dropping probability at the buffers, a simulation model that assumes symmetric access rights among the nodes is developed based on Poisson statistics. Extensive numerical results show that the proposed protocol achieves apart from high bandwidth exploitation for a wide range of offered load, fairness of queuing delay and dropping events among the different packets size categories.

Keywords—Asynchronous transmission, collision avoidance, wavelength division multiplexing.

I. INTRODUCTION

RECENT studies of high-speed Metropolitan Area Networks (MANs) are mostly interested in the effective exploitation of the enormous fiber bandwidth as well as in the employment of the Wavelength Division Multiplexing (WDM). The latest technique is the most preferable solution in optical high-speed networks, since it achieves to divide the high fiber bandwidth into several wavelengths each operating in lower data rates [1]-[4].

In literature, there are several experimental results that have proven that the MANs traffic is not homogeneous and the main traffic consists of Internet packets whose size is not fixed [5]. Despite this fact and mostly for simplification reasons, the vast majority of the WDM Access (WDMA) protocols assume only the Ethernet Maximum Transfer Unit (MTU) of 1500 Bytes as Internet Protocol (IP) packet [6]-[8]. On the other hand, few WDMA protocols consider packets of variable packet sizes [9]-[11]. Although this assumption is more realistic, it complicates the analytical modeling providing longer simulation programs.

As far as it concerns the nature of the adopted transmission strategy, in literature most of the WDMA protocols adopt the synchronous transmission strategy. This means that the time is organized into consecutive cycles or frames, while the transmission, the reception, the packets allocation into buffers are performed during them [7]-[11]. On the contrary, experimental measurements in modern WDM networks have

shown that in such networks the packets arrival is performed in an asynchronous way. This is the reason why, WDMA protocols that assume the asynchronous transmission strategy are able to give a more realistic study of the performance measures [12]-[14].

It is obvious that the performance measures evaluation of WDM networks is mainly affected by the collisions over the WDM wavelengths and by the receiver conflicts. Both of these performance parameters provide serious packet loss and they eliminate the performance. Especially, they provide throughput decrease, queuing delay and packet dropping probability increase. For this reason, the main interest of the WDMA protocols is focused on the adoption of the proper transmission strategies that effectively face them and provide performance improvement. In literature, most of the WDMA protocols perform carrier sensing before packet transmission to detect whether the packet that they are willing to transmit collides with an already transmitted one over the dedicated wavelength. If this fact happens, they either retransmit their packet [12], or provide partial packet collision with fragmentation and reassembly.

Moreover, another factor that categorizes the WDMA protocols is the node architecture. Particularly, in literature many WDMA protocols introduce at each node one or more fixed receivers to avoid the receiver collisions [12], [15]. In this node architecture category, if a single fixed receiver is used at each node, bandwidth under-utilization is provided since, in case that the dedicated for reception channel is not free, the attempting for transmission node cancels the transmission although there may exist other channels availability. For this reason, the node architecture that occupies a number W of fixed receivers (equal to the number of wavelengths) is preferable. It is evident that this node architecture requires high cost since it occupies many fixed receivers. On the other hand, the node architecture that uses a tunable receiver per node instead of a set of fixed receivers is more effective. This is because it eliminates the financial cost while it effectively exploits the fiber bandwidth, since it uses all the wavelengths for reception.

An extensive research in literature may provide us with many relative studies. Especially, an asynchronous transmission WDM ring network with an unslotted Carrier Sense Multiple Access with Collision Avoidance (CSMA/CA) protocol is presented in [12]. Each node is equipped with a tunable transmitter and a fixed tuned receiver, while multiple packet sizes are assumed. The protocol suffers from bandwidth waste because of the retransmission policy in case of channel collision. Also in [13], [14], two asynchronous

P. A. Baziana is with the National Technical University of Athens, Greece (phone: +302107722145; fax: +302107722145; e-mail: baziana@central.ntua.gr).

transmission WDM ring protocols with CSMA with Idle Detection (CSMA/ID) are introduced assuming variable packet sizes. Each node uses a tunable transmitter and W fixed tuned receivers. Although these protocols face the channel collisions, they address long delay. The CSMA/CA protocol for the Dual Bus Optical Ring Network (DBORN) is presented in [15]. Each node uses a pair of fixed tuned transceivers, while a hub node performs the communication in a centralized way increasing the protocol complication.

In this paper, we study an asynchronous transmission WDMA protocol suitable for ring MANs. The size of the offered load packets is variable. We assume five major sizes of IP packets based on the measurement of the Sprint IP backbone network: 40, 211, 572, 820 and 1500 Bytes [5]. The 40 Bytes size is for Transmission Control Protocol (TCP) acknowledgements (ACKs). The 572 Bytes and 1500 Bytes are the most common default MTUs. The 211 Bytes packets correspond to a Content Distribution Network (CDN) User Datagram Protocol (UDP) application that uses an unregistered port and carries a single 211 Bytes packet. The 820 Bytes packets are generated by media streaming services.

The proposed WDMA protocol adopts a node architecture according which each node is occupied by a tunable transmitter and a tunable receiver. In this way, all wavelengths may be used for both transmission and reception. Since there is no provision for a dedicated channel for transmission at each node, in the proposed WDMA protocol the channel collisions are properly faced by utilizing a tunable transmitter and making use of the carrier sensing technique to always monitor the wavelengths activity to address collisions-free transmission. On the other hand, in order to effectively face the possible receiver conflicts, the proposed WDMA protocol adopts a transmission strategy that totally avoids the receiver collisions. So, high bandwidth utilization is achieved, especially under high load conditions.

In order to evaluate the proposed WDMA protocol performance, we developed a simulation model based on Poisson statistics for symmetric access rights scenario. This means that each node may transmit or receive a data packet with same probability. Extensive simulation results prove that the proposed WDMA protocol and network architecture reaches high throughput, while it achieves low delay and packet dropping probability at the buffers for a wide range of offered load conditions.

Our study is carried out as follows: Section II describes the network model and assumptions. Performance evaluation is given in Section III. Section IV outlines some conclusions.

II. NETWORK MODEL AND ASSUMPTIONS

We consider a uni-directional single-fiber multi-channel ring network architecture that uses W wavelengths to interconnect a finite number N of access nodes on a wide area scale, as Fig. 1 shows. The W wavelengths $\lambda_1, \dots, \lambda_w$ are used for data packets transmission. Each node uses a tunable transmitter and a tunable receiver. In this way, all channels are effectively exploited since they can be used for both transmission and reception.

Each node interface has add-drop capabilities to access the ring. Also, it is connected to one or more access networks, as Fig. 1 shows. In the direction from the access networks to the ring, the node serves as a concentrator that stores the access networks traffic in a multi-buffer structure. In the direction from the ring to the access networks, the node terminates the optical signals and delivers the packets to the attached access networks.

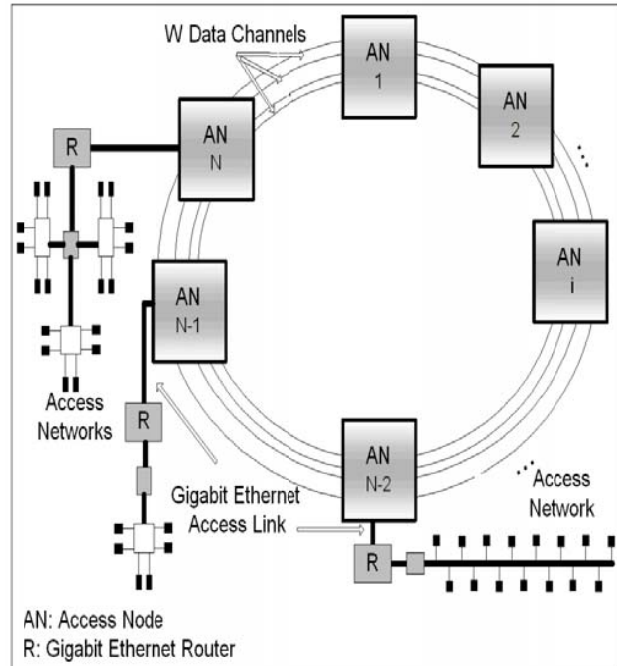

Fig. 1 Network architecture

We consider that the packets from the access networks have five different sizes, which are 40, 211, 572, 820 and 1500 Bytes [5]. According to [5], the probability distribution of packet sizes on the access links is: 10% of the offered traffic is 40 Bytes packets, 20% is 211 Bytes packets, 10% is 572 Bytes packets, 20% is 820 Bytes packets, and the remaining 40% is 1500 Bytes packets.

At each node, five buffers accommodate the incoming packets according to their size, constituting five parallel queues for transmission. The size of each buffer is related to the probability distribution of packet sizes on the access links. Thus, the size of the buffers that accommodate packet size 40 and 572 Bytes is 100 packets, the size of the buffers for packet size 211 and 820 Bytes is 200 packets, while the size of the buffer for packet size 1500 Bytes is 400 packets. Arriving packets are discarded when the relative buffer is full.

For the proposed network model, we consider symmetric traffic conditions, i.e. a node may transmit a packet to each of the other nodes with equal probability.

We apply the destination stripping scheme, according which the destination node is responsible to mark the space of a channel that carries a data packet empty after its reception. A modification is followed to restrict the immediate reuse of the

channel space that has just been marked empty [16]. This provides a simple fairness mechanism towards the downstream nodes.

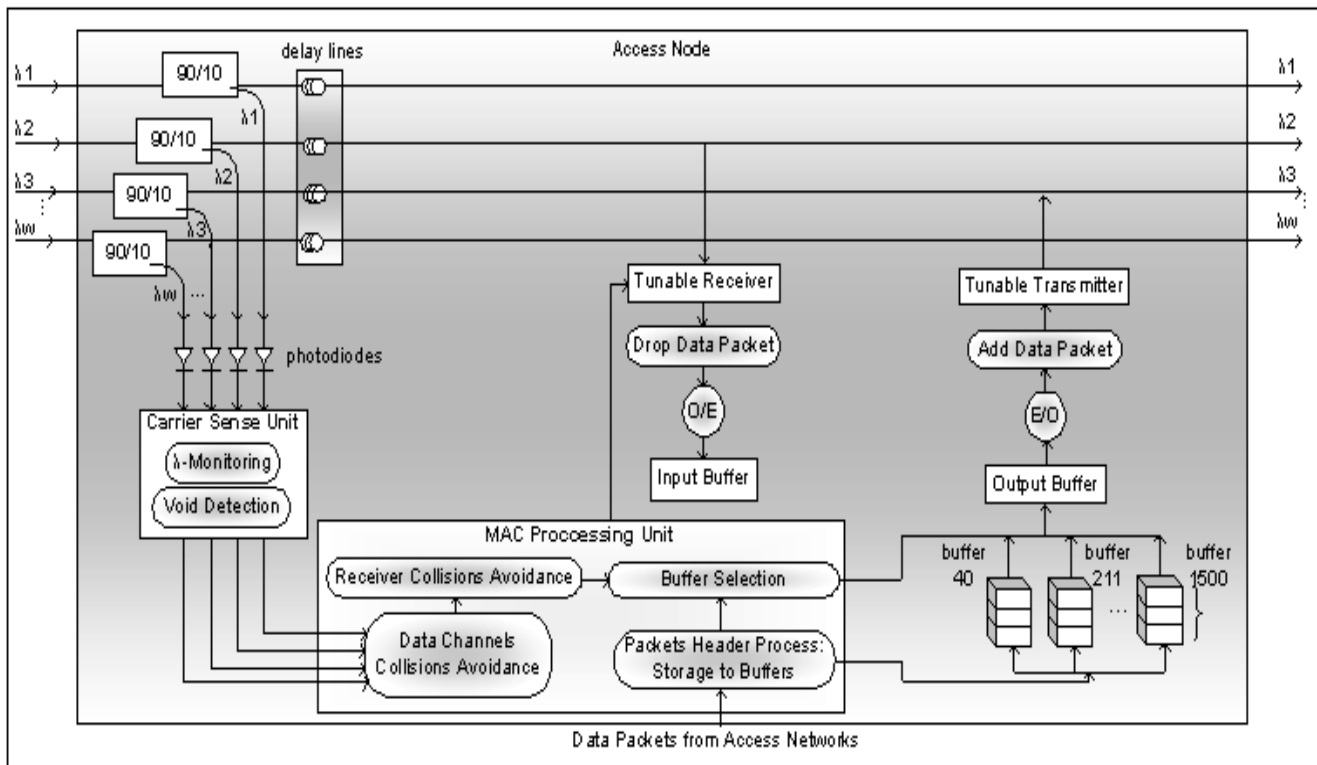

Fig. 2 Access node logical architecture

Each node is assigned a different sub-carrier tone. When a node wishes to transmit to a specific destination, it transmits the packet onto the free space of a wavelength and multiplexes the destination's sub-carrier tone which represents the packet's destination address. Each node constantly monitors all channels to detect its own sub-carrier tone. The absence of a sub-carrier tone indicates that there is no packet on the corresponding wavelength. This implementation was experimentally tested in HORNET project [17], [18] where sub-carrier tones are transmitted along with the data to identify the destination.

Each node retains the upstream traffic flow within the optical layer, while monitoring the wavelengths activity. So, each node first uses an optical splitter to separate the incoming signal into two identical parts: the main transit signal and its copy used for control purposes. These are depicted in Fig. 2 that presents the access node logical architecture.

With regard to the control part, as in [19], low bit rate photodiodes are used to detect the activity of the upstream wavelengths. Once a free state of the medium is detected, the Medium Access Control (MAC) unit measures the size of the progressing void.

To do so, at each node W fixed delay lines are assumed, one for each wavelength providing propagation delay of time interval td . The time interval td equals to the transmission time t_m of the 1500 Bytes packet augmented by the MAC

processing time and the guard band.

The node begins transmitting a packet to fill the void only if the null period is large, i.e. at least equal to the size of the packet to be inserted. Undelivered data will remain buffered until a sufficient void space is detected. So, channel collisions are avoided.

A. Transmission Mode

Each node always inspects each wavelength to detect both the voids and the transmitted packets. If the node has at least one non-empty transmission buffer and has the right to transmit according to the channel reuse strategy, then it runs the following algorithm to schedule the transmissions that maximizes throughput. The buffer selection for transmission algorithm is run by the MAC processing unit after the end of time delay t_m .

Especially, this algorithm consists of the next steps:

- 1) *Channel Selection for Transmission*: First, the node that attempts transmission selects one of the W wavelengths, let's say the channel i , for transmission. The selection criterion is the total channel void (i.e. total free space) during the time period t_m . Thus, the node selects for transmission the channel i that has the longer total void during the time period t_m . In this way, the total channel bandwidth that can be used for packets transmission is maximum, while the throughput achieved is really

optimum. Also, since the node transmissions will be performed over the selected channel i , the elimination of the effect of the tunable transmitter tuning time is appropriately achieved.

- 2) *Receiver Collisions Avoidance*: Then the node finds the destination addresses of the data packets that are already transmitted over the remaining $W-1$ wavelengths, apart from the selected for transmission channel i . So, it excludes these destinations addresses and it schedules its possible transmissions to the remaining destination nodes. In this way, it manages to resolve the receiver conflicts, while it achieves to eliminate the effect of the tunable receivers tuning time.
- 3) *Packet Transmission*: The node sorts the packet sizes in a descending order and it starts the transmission algorithm from the buffer with the bigger packet size that is not empty. While the free space in the selected channel i is larger than the size of the packets in the buffer (augmented by the guard band space t_g between two consecutive packets), the node checks if the current packet in the buffer does not have the same destination with any of the transmitted packets over the remaining $W-1$ wavelengths. In this case, the node transmits the current packet over the dedicated free space of the selected channel i and runs the same transmission algorithm for the next void of channel i .

B. Reception Mode

Since each node continuously inspects the activity of all wavelengths with its transceivers, it probes the destination ID for each arriving packet. The packet is received from the ring if its destination ID matches with the ID of the node. In this case the relative space on the wavelength is marked empty, according with the destination stripping scheme that is followed. This empty space cannot be used by the same node and it is release to the downstream node.

III. PERFORMANCE EVALUATION

A specific network simulator based on C programming has been developed to evaluate the proposed protocol performance measures. In this network simulator, we simulate the traffic received by an access node from the attached networks using Poisson sources. The inverse transformation method is used to generate the Poisson traffic [20]. Also, the time each simulation was run, was long enough in order to obtain the steady-state conditions.

In our network simulator, the access networks traffic is generated prior to the ring network simulation and it is stored in appropriate files. The packets size generation follows the probability distribution mentioned in [5]. At each access node, the generated data packets are queued at multiple buffers according to their size, following their generation time. Finally, a guard band time interval $t_g = 50$ ns like [21] is considered.

TABLE I
NETWORK PARAMETERS

Network Parameter	Value
Ring length L_R	144 K m
Propagation delay latency T_p	720 μ s
Number of WDM data wavelengths W	4
Number of access nodes N	16
Wavelengths data rate R_w	2.5 Gb/s
Rate of data wavelengths on the ring R	10 Gb/s
Packet size L_1	320 bits (40 Bytes)
Packet size L_2	1688 bits (211 Bytes)
Packet size L_3	4576 bits (572 Bytes)
Packet size L_4	6560 bits (820 Bytes)
Packet size L_5	12000 bits (1500 Bytes)
Buffer size B_1 (for packets 40 Bytes)	100
Buffer size B_2 (for packets 211 Bytes)	200
Buffer size B_3 (for packets 572 Bytes)	100
Buffer size B_4 (for packets 820 Bytes)	200
Buffer size B_5 (for packets 1500 Bytes)	400
Transmission time T_1 (for 40 Bytes)	0.128 μ s
Transmission time T_2 (for 211 Bytes)	0.6752 μ s
Transmission time T_3 (for 572 Bytes)	1.8304 μ s
Transmission time T_4 (for 820 Bytes)	2.624 μ s
Transmission time T_5 (for 1500 Bytes)	5 μ s

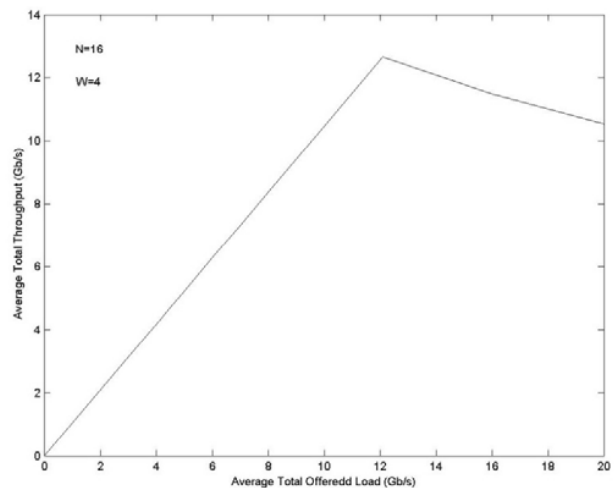

Fig. 3 Average throughput vs average load for $N=16$, $W=4$

We assume the network configuration which is presented in Table I. Especially, Table I provides each network parameter and its relative value.

Fig. 3 presents the average total throughput versus the average offered load, for the proposed protocol for $N=16$ and $W=4$. As it is representatively shown in Fig. 3, for loads up to almost 13 Gb/s, the proposed protocol is able to serve all the incoming packets and the total offered load is able to access the ring without being dropped at the buffers. This is the reason why, in this wide offered load range the average total throughput has almost the same value with the offered load. This fact consist a significant advantage of the proposed protocol.

On the contrary, for loads values higher than 13 Gb/s, the average throughput curve is a decreasing function of the

offered load. This means that as the offered load gets higher the throughput obtained is getting lower. This is because in this high offered load conditions, the proposed protocol reaches saturation, since the available free voids for transmission are getting fewer. In this way, the algorithm that selects the appropriate buffer for transmission plays a critical role to the performance. In other words, although this algorithm ensures the transmission without collisions that maximizes throughput for lower loads, in high load conditions it has to properly face the little available bandwidth. For example, for offered load 20 Gb/s the throughput reaches almost 10.4 Gb/s.

Fig. 4 must be remarked in conjunction with Fig. 5. Thus, Fig. 4 illustrates the average queuing delay at the buffers versus the average offered load for $N=16$ and $W=4$, while Fig. 5 shows the average packet dropping probability at the buffers versus the average offered load, for $N=16$ and $W=4$.

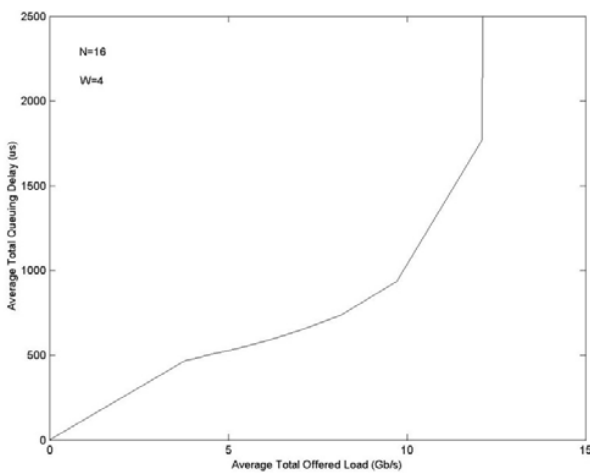

Fig. 4 Average queuing delay vs average load for $N=16, W=4$

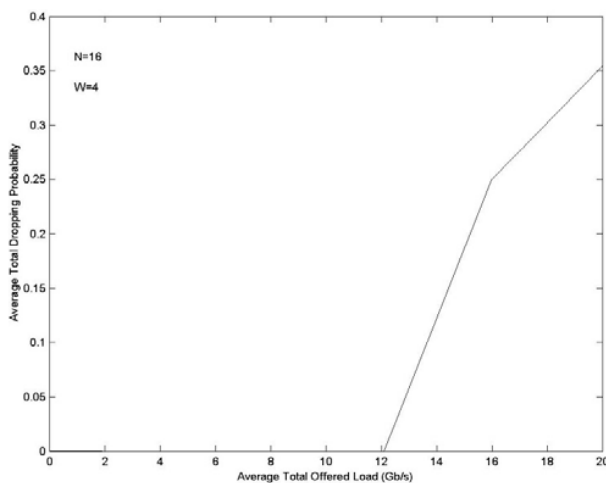

Fig. 5 Average dropping probability vs average load for $N=16, W=4$

As Fig. 4 presents, for offered loads values up to almost 12 Gb/s the proposed protocol reaches low average queuing delay

at the buffers. Also, for the same offered load range, the average packet dropping probability at the buffers has almost zero value, as Fig. 5 illustrates. The explanation is based on the fact that for this offered load range, almost all the incoming packets can be served by the proposed protocol and are able to become actual throughput, as it is discussed in Fig. 3. This fact has as an immediate result that for loads up to 12 Gb/s, there are enough free voids at the wavelengths in order for the incoming traffic to be transmitted, while the available bandwidth is properly exploited by adopted buffer selection for transmission algorithm to keep very low values of queuing delay and to almost eliminate the dropping probability achieved.

On the contrary for higher offered loads, the queuing delay as well as the packet dropping probability increase and reach high values. This behavior is a direct result of the remarks on Fig. 3. Thus, as the offered load increases to values higher than 12 Gb/s, the network reaches saturation and the throughput begins to decrease, as Fig. 3 show. This is the reason why, congestion conditions appear at the buffers, since the incoming packets cannot be served by the network and are stored at long queues at the buffers waiting for long time to be transmitted. This fact has as an immediate result the high average queuing delay values, as Fig. 4 illustrates. Thus, as the offered load is getting higher, the buffers are getting full of stored packets and are not able to accommodate more incoming traffic. As a direct result at this high offered load values, the incoming packets face high dropping probability at the buffers, as Fig. 5 presents.

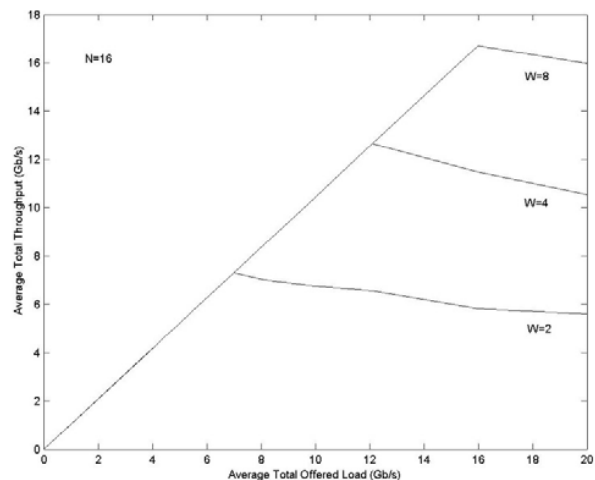

Fig. 6 Average throughput vs average load for $N=16, W=2, 4, 8$

It is obvious that the proposed protocol performance depends on the number of wavelengths W . This is studied in Figs. 6-8 that present the average throughput, the average queuing delay and the average packet dropping probability respectively versus the average load, for $W=2, 4, 8$ and $N=16$. As it shown in Fig. 6 for low loads and for all W values, all offered load seems to be able to access the ring and become actual throughput. On the contrary at heavy loads, saturation is noticed. The saturation load is an increasing function of W , as

Figs. 6-8 show. Thus, the congestion load is: 7 Gb/s for $W=2$, 12 Gb/s for $W=4$ and 16.5 Gb/s for $W=8$.

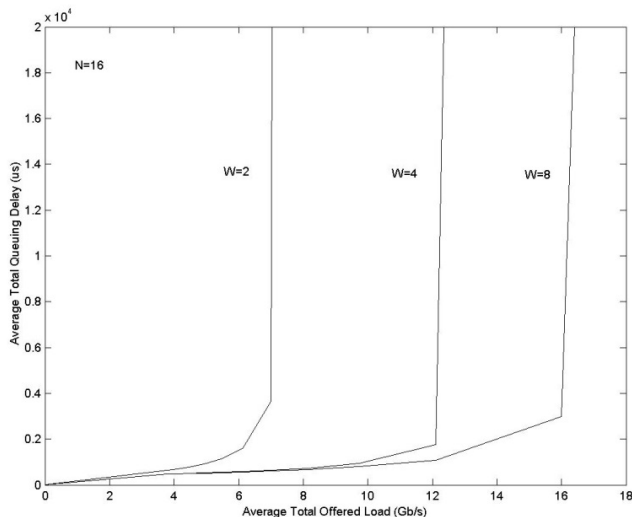

Fig. 7 Average queuing delay vs average load for $N=16$, $W=2, 4, 8$

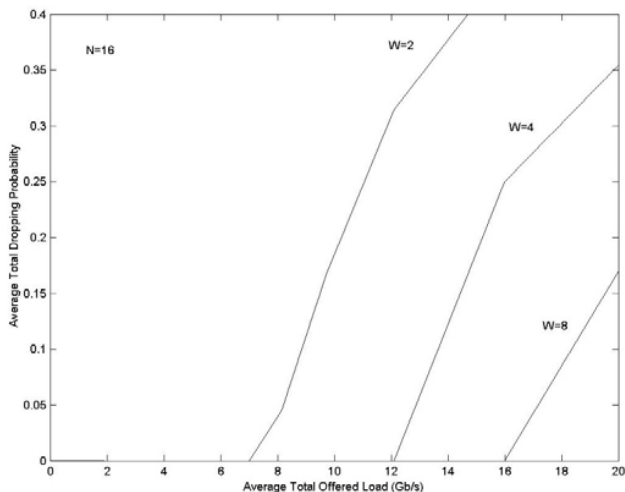

Fig. 8 Average dropping probability vs av. load for $N=16$, $W=2, 4, 8$

Similar, the throughput achieved is an increasing function of W . For example for offered load 16 Gb/s, the average throughput achieved is: 16 Gb/s for $W=8$ (which means that the entire incoming load can access the ring), 11.5 Gb/s for $W=4$, and 6 Gb/s for $W=2$. The explanation for this behavior is based on the effect of the adopted buffer selection for transmission algorithm on the network performance. In other words, as the number W increases the probability of finding a channel with longer total void for transmission increases too. This fact leads to higher average throughput values, as Fig. 6 representatively shows.

IV. CONCLUSION

In this study, we propose an efficient access algorithm for asynchronous transmission in WDM ring MANs. The

proposed protocol ensures that the packet communication is totally collisions-free, since it avoids both the channel and the receiver collisions. In order to evaluate the proposed protocol performance in real traffic conditions, we consider various sizes of IP packets according to the network measurements of [5]. Thus, the proposed protocol uses at each access node a number of buffers to accommodate the incoming traffic, equal to the number of IP packets categories. In addition, the adopted access strategy takes into account the packet size variation and coordinates the transmission from the suitable buffers in order to maximize throughput. This fact appears to be the main innovation of our study.

REFERENCES

- [1] B. Mukherjee, *Optical communication networks*. McGraw-Hill, 1997, pp. 5-7.
- [2] R. Ramaswami, and K. Sivaraja, *Optical networks: a practical perspective*. Morgan Kaufmann Publishers Inc., 1998, pp. 503-504.
- [3] C. Brackett, "Dense wavelength division multiplexing networks: Principles and applications", *IEEE J. Select. Areas Commun.*, vol. 8, pp. 948-964, Aug. 1990.
- [4] B. Mukherjee, "WDM optical communication networks: Progress and challenges", *IEEE J. Select. Areas Commun.*, vol. 18, pp. 1810-1824, Oct. 2000.
- [5] C. Fraleigh, S. Moon, B. Lyles, C. Cotton, M. Khan, D. Moll, R. Rockell, T. Seely, S.C. Diot, "Packet-level traffic measurements from the Sprint IP backbone", *IEEE Network*, Vol. 17, 6, pp. 6-16, 2003.
- [6] K. Bengi, H. and R. van As, "Efficient QoS support in a slotted multihop WDM metro ring", *IEEE J. Select. Areas Commun.* vol. 20, pp. 216-227, Jan. 2002.
- [7] C. Jelger, and J. Elmighani, "A slotted MAC protocol for efficient bandwidth utilization in WDM metropolitan access ring networks", *IEEE J. Select. Areas Commun.*, vol. 21, pp. 1295-1305, Oct. 2003.
- [8] C. Jelger, and J. Elmighani, "Performance of a slotted MAC protocol for WDM metropolitan access ring networks under self-similar traffic", in *Proc. ICC 02 Int. Conf. Commun.*, pp. 2806-2811, 2002.
- [9] K. Bengi, "Access protocols for an efficient and fair packet-switched IP-over-WDM metro network", *Computer Networks*, vol. 44, pp. 247-265, Feb. 2004.
- [10] B. Pranggono, J. Elmighani, "Performance evaluation of survivable WDM based SANs in a metro ring network", *Optik International Journal for Light and Electron Optics*, Vol. 123, 4, pp. 366-370, 2011.
- [11] B. Pranggono, J. Elmighani, "Performance analysis of a metro WDM ring networks with variable-length packets under symmetric and asymmetric traffic", *Optical Fiber Technology*, vol. 17, 3, pp. 171-178, 2011.
- [12] K.Soo Kim, L.G. Kazovsky, "Design and performance evaluation of scheduling algorithms for unslotted CSMA/CA with backoff MAC protocol in multiple-access WDM ring networks", *Information Sciences*, 149, pp. 135-149, 2003.
- [13] Jih-Hsin Ho, Wen-Ping Chen, Wen-Shyang Hwang, Ce-Kuen Shieh, "Performance evaluation of CSMA/ID MAC protocol for IP over WDM ring networks", *International Journal of Communication Systems*, 21, pp. 1155-1170, 2008.
- [14] Wen-Ping Chen, Shih-Wei Kau, Wen-Shyang Hwang, Bin-Yih Liao, and Wen-Tsung Hu, "A Collision Avoidance Protocol for Supporting All-optical Ring Network", in *Proc. Eighth International Conference on Intelligent Systems Design and Applications*, pp. 535-540, 2008.
- [15] N. Bouabdallah, A. Beylot, E. Dotaro, G. Pujolle, "Resolving the Fairness Issues in Bus-Based Optical Access Networks", *IEEE Journal on Selected Areas in Commun.*, Vol. 23, 8, pp. 1444-1457, Aug. 2005.
- [16] P.A.Baziana, I.E.Pountourakis: "An Efficient Metropolitan WDM Ring Architecture for a Slotted Transmission Technique", *IEEE Journal of Lightwave Technology*, Vol. 26, No. 19, pp. 3307-3317, October 1, 2008.
- [17] K.V. Shrikhande, I.M. White, D. Wonglumsom, S.M. Gemelos, M.S. Rogge, Y. Fukashiro, M. Avenarius, L.G. Kazovsky, "HORNET: a packet-over-WDM multiple access metropolitan area ring network", *IEEE Journal on Selected Areas in Commun.*, Vol. 18, 10, pp. 2004-2016, 2000.

- [18] I.M. White, M.S. Rogge, K. Shrikhande, L.G. Kazovsky, "A summary of the HORNET project: a next-generation metropolitan area network" *IEEE Journal on Selected Areas in Commun.*, Vol. 21, 9, pp. 1478–1494, 2003.
- [19] R. Gaudino et al., "RINGO: A WDM ring optical packet network demonstrator," in *Proc. ECOC*, vol. 4, Amsterdam, The Netherlands, Sep. 2001, pp. 620–621.
- [20] R. Jain, *The art of computer systems performance analysis*. Wiley, 1991.
- [21] K. Soo Kim, D. Gutierrez, Fu-Tai An, and G. Kazovsky., "Batch Scheduling Algorithm for SUCCESS WDM-PON", in *Proc. IEEE GLOBECOM*, 2004, pp. 1835-1839.