

Acid Fuchsin Dye Based PMMA Film for Holographic Investigations

G. Vinitha, A. Ramalingam

Abstract—In view of a possible application in optical data storage devices, diffraction grating efficiency of an organic dye, Acid Fuchsin doped in PMMA matrix was studied under excitation with CW diode pumped Nd: YAG laser at 532 nm. The open aperture Z-scan of dye doped polymer displayed saturable absorption and the closed aperture Z-scan of the samples exhibited negative nonlinearity. The diffraction efficiency of the grating is the ratio of the intensity of the first order diffracted power to the incident read beam power. The dye doped polymer films were found to be good media for recording. It is observed that the formation of gratings strongly depend on the concentration of dye in the polymer film, the intensity ratios of the writing beams and the angle between the writing beams. It has been found that efficient writing can be made at an angle of 20° and when the intensity ratio of the writing beams is unity.

Keywords—Diffraction efficiency, Nonlinear Optical material, saturable absorption, Surface-relief-gratings.

I. INTRODUCTION

NONLINEAR Optical polymeric materials have been identified as strong candidates for emerging photonic data processing technologies. In this regard, organic materials are most attractive owing to the known rich variety of organic compounds and the inherent flexibility in synthesizing such compounds with desired properties [1]. Organic materials offer advantages of large susceptibilities, high laser damage threshold, faster response time and versatility of molecular structural modifications [2]-[4], [6]. In general these materials consist of molecular fragments displaying NLO activity or highly colored chromophores, covalently attached to a polymeric host material. One of the technologically promising phenomenon applicable to some of these materials is the light-induced modulation of index of refraction of the material through the photorefractive effect. It has been reported that large surface modulations can be reversibly photo induced on surfaces of azo polymer films [7]-[10]. The photo induced surface-relief-gratings (SRGs) are formed upon exposure to an interference pattern of Ar ion laser beams at modest intensities [11]. Photorefractive materials combine photoconductivity and the electro-optic effect. They are expected to be used for high density optical data storage, associative image processing techniques including dynamic holography and image amplification, spatial light modulation, programmable

interconnections in integrated optics and simulations of neural networks and associative memories with parallel signal processing.

In this article, Acid Fuchsin dye doped in PMMA films were investigated for grating formation using diode pumped Nd:YAG laser of wavelength 532 nm and He-Ne laser was used as a read out beam. The diffraction efficiency of the dye doped polymers was achieved through varying the optical densities of the dyes in the polymer films, spatial frequency and intensity ratio of the writing beams.

II. EXPERIMENTAL SET-UP

The optical quality films of the dye doped polymers were synthesized at 0.4mM concentration by bulk polymerization technique [9]. MMA and 1-butanol are taken in the ratio 4:1 (v/v). Known weights of dyes are dissolved in this mixture. 2,2-azobis (isobutyronitrile) is used as an initiator for polymerization. The solution is taken in polymerizing tubes and kept in the nitrogen atmosphere. Bulk polymerization is carried out in a temperature controlled water bath. Once the solution is viscous, the viscous dye solution with initiator mixture is poured on to a petridish placed in a glass enclosure, kept at a temperature of 40°C in a temperature controlled water bath and a film of thickness 0.9mm was obtained.

Z-scan experiments of the dye in liquid (ethanol) and solid (PMMA) media show that Acid Fuchsin dye exhibits high third order nonlinearity which can be exploited for optical data storage [5]. The Z-scan experiments were performed using a 532 nm diode pumped Nd:Yag laser beam (Coherent Compass™ 215M-50), which was focused by 3.5 cm focal length lens. The laser beam waist ω_0 at the focus is measured to be $15.84\ \mu\text{m}$ and the Rayleigh length to be 1.48 mm. The schematic of the experimental set-up is as shown in Fig. 1. A 1 mm wide optical cell containing 0.4 mM concentration of dye in 1-Butanol is translated across the focal region along the axial direction that is the direction of the propagation laser beam. The transmission of the beam through an aperture placed in the far field was measured using photo detector fed to the digital power meter (Field master GS-coherent). The experiment is repeated for an open aperture Z-scan in which the aperture is replaced with a lens to collect the entire laser beam transmitted through the sample. Generally the measurements of the normalized transmittance versus sample position, for the cases of closed and open aperture, allow determination of the nonlinear refractive index, n_2 and the saturation absorption coefficient, β . Here, since the closed aperture transmittance is affected by the nonlinear refraction and absorption, the determination of n_2 is less straightforward

G.Vinitha is with Division of Physics, School of Advanced Sciences, VIT University, Chennai- 600127, India (Phone: 044-3993-1247; fax: 044-3993-2555; e-mail: svini2005@yahoo.co.in).

A. Ramalingam is with Centre for Laser Technology, Department of Physics, Anna University, Chennai-600025, India (e-mail: ramalingam_a@yahoo.com).

from the closed aperture scans. It is necessary to separate the effect of nonlinear refraction from that of the nonlinear absorption. A method to obtain purely effective n_2 is to divide the closed aperture transmittance by the corresponding open aperture scans. The same procedure was repeated for dye in PMMA matrix. The closed aperture, open aperture and the ratio of closed to open aperture z-scan signatures of 0.4 mM concentration of dye in n-butanol and in PMMA film are as shown in Figs. 2 (a), (b) and (c) respectively.

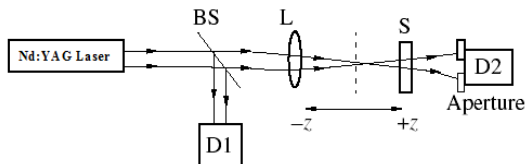

Fig. 1 Schematic of experimental arrangement for the Z-scan measurement BS-Beam Splitter, L-Lens, S-Sample, D1 and D2-Detectors

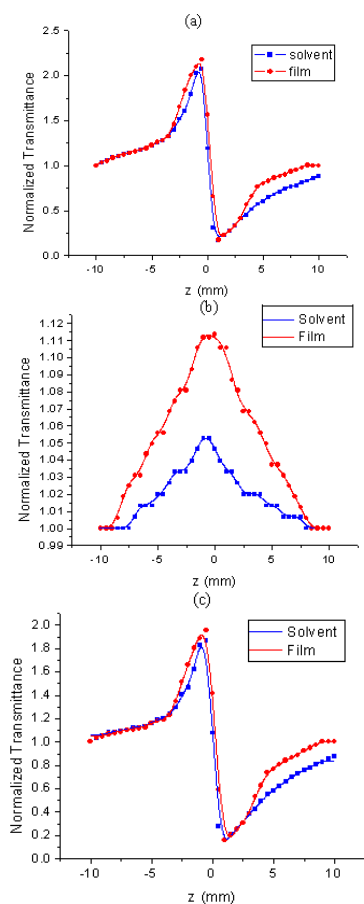

Fig. 2 Z-scan data of the 0.4 mM Acid fuchsin dye in n-butanol (liquid medium) and in dye doped polymer film (solid medium) at $I_0=4.38 \text{ KW/cm}^2$ (a) closed aperture scan ($S=0.035$) (b) open aperture scan ($S=1$) and (c) the division of a by b

This material exhibits negative optical nonlinearity. The dye at 0.4mM concentration exhibited nonlinear refractive index

coefficient, $n_2 = -8.72 \times 10^{-8}$ and $-10.308 \times 10^{-8} \text{ (cm}^2/\text{W)}$ in liquid and solid media, respectively, nonlinear absorption coefficient, $\beta = -7.69 \times 10^{-4}$ and $-8.294 \times 10^{-4} \text{ cm/W}$ in liquid and solid media, respectively and nonlinear susceptibility, $\chi(3) = 4.33 \times 10^{-6}$ and $5.13 \times 10^{-5} \text{ esu}$ in liquid and solid media respectively. These results show that Acid Fuchsin dye has potential applications in nonlinear optical devices.

The schematic of the experimental set-up for formation of gratings is as shown in Fig. 3. The optical setup for recording the grating in the polymer film samples is explained as follows. The beam from an Nd-YAG laser output wavelength 532 nm was used to record the grating. The beam from the laser was split into two beams of equal intensity using a dielectric coated beam splitter and they were allowed to interfere. The interfering angle was adjusted to 10 degrees. The polymer films prepared were kept at the region of superposition of the two writing beams. The experiment was performed on a vibration isolation table. The growth of the grating was monitored by illuminating the region of superposition with a beam of 30 mW He-Ne laser at 632.8 nm (05-LHP-928, Melles Griot). The intensity of the first order diffracted beam was monitored with a photo detector combined with digital power meter (Coherent model Fieldmaster GS).

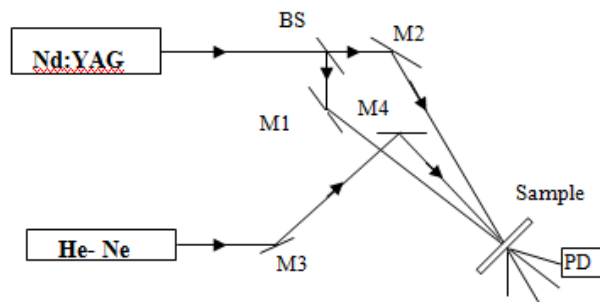

Fig. 3 Experimental set-up for grating formation BS- Beam splitter, M- Mirrors, PD-Photo detector

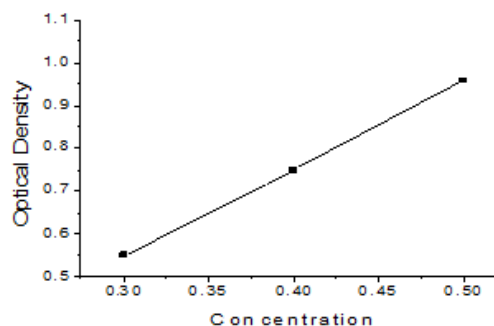

Fig. 4 Optical densities of the Acid Fuchsin dye at different concentrations

III. RESULTS AND DISCUSSION

Highly efficient materials are preferred for good recording. The diffraction efficiency of the grating is the ratio of the intensity of the first order diffracted power to the incident read

beam power. The grating formation is found to depend on (i) intensity ratio of the interfering beams, (ii) concentration of dye in the polymer film and (iii) the spatial frequency of recording.

As the thickness of the films was slightly different, the optical densities at these concentrations are found out. The variation of optical densities with concentration is shown in Fig. 4. The interfering angle was changed as 10, 20, 30 and 40 degrees. The grating formation was also studied for 50:50 and 70:30 intensity ratios of the writing beams. The plots were drawn between first order-diffracted beam power vs time for various concentrations, different interfering angles and different intensity ratios of writing beams for the Acid Fuchsin dye doped polymers.

A. Formation of Grating as a Function of Optical Density at Different Concentrations

Different concentrations of polymer films were exposed to interference pattern and the intensity of the first order-diffracted beam was measured continuously for 30 mins, maintaining the power of the writing beams at 21 mW each and the angle between the interfering beams at 20 degrees. The variation of the intensity of the first order diffracted beam for optical densities at different concentrations of the dye doped polymer films are graphically presented in Fig. 5 (a). We observe that the rate of formation of grating increases with an increase in the concentration for the dye doped polymers. The diffraction efficiency of the gratings thus written reaches a maximum value and then start decreasing. This may be due to the degradation of the grating structure after reaching the saturation value due to over exposure.

B. Formation of Grating as a Function of Intensity Ratio of the Interfering Beams

Ascertaining that the intensities of the writing beams remained practically constant for the entire recording period, experiments have been conducted by varying the intensity ratio of the writing beams. The fringe contrast depends on the intensity ratio and hence this parameter becomes important. The rate of formation of the grating is monitored by measuring the diffracted intensities in the first order. Fig. 5 (b) show the variation of the first order diffracted intensity with time for two different intensity ratios (50:50 and 70:30) for the dye doped polymer film. It is seen that the diffraction efficiency is maximum for an intensity ratio of unity.

C. Formation of Grating as a Function of Spatial Frequency

Resolution and storage capability of materials are important factors determined by spatial frequency. The first order diffraction efficiency has been investigated as a function of spatial frequency and the results are shown in Fig. 5 (c) for the dye doped polymer. The angle between the interfering beams is varied to be 10, 20, 30, and 40 degrees and the effect of the change in efficiency of the grating formation is studied. The fringe spacing (Λ) is calculated by (1):

$$\Lambda = \lambda / [2 \sin(\theta/2)] \quad (1)$$

where λ and θ are the wavelength and incident angle of the writing beams respectively.

By changing θ from 10 to 40 degrees, Λ is varied from 3.05 μm to 0.78 μm . The maximum diffraction efficiency was observed at an angle of 20 degrees. The spatial resolution for $\theta = 10, 20, 30$ and 40 degrees changes from 3.05 μm , 1.53 μm , 1.03 μm and 0.78 μm which corresponds to a spatial frequency change of 328, 654, 971 and 1282 lines mm^{-1} . Variation of diffracted efficiency with different angles between writing beams has been shown in Fig. 6.

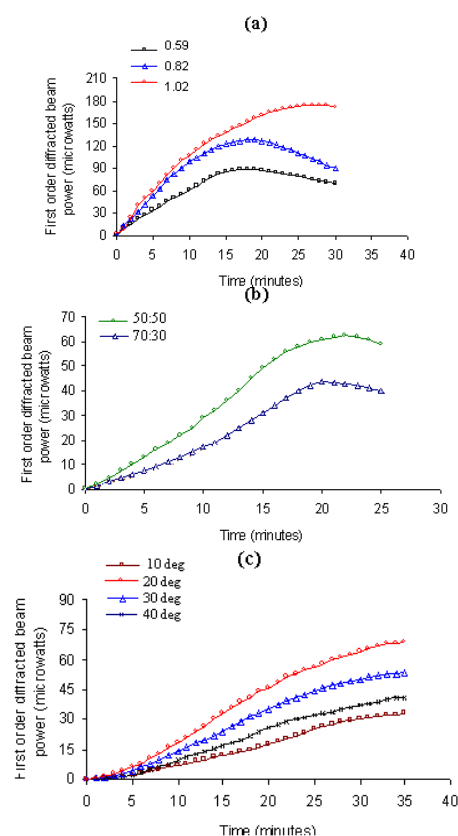

Fig. 5 Variation of first order diffracted beam power with time for different (a) optical densities at different concentrations (b) intensity ratio of writing beams (c) angles between writing beams of Acid Fuchsin doped polymers

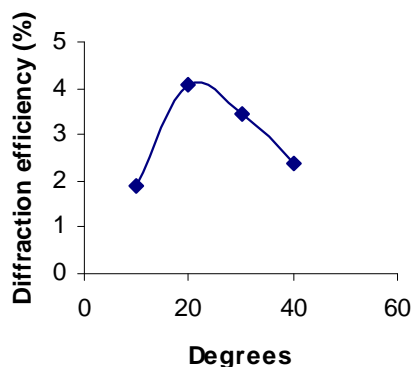

Fig. 6 Variation of diffracted efficiency with different angles between writing beams for Acid Fuchsin doped polymer

Table I summarizes the results of diffraction efficiencies of Acid Fuchsin dye doped polymers for different concentrations, intensity ratio of the interfering beams, spatial frequencies.

TABLE I

DIFFRACTION EFFICIENCIES OF ACID FUCHSIN DYE DOPED POLYMERS FOR DIFFERENT (A) CONCENTRATIONS, (B) INTENSITY RATIO OF INTERFERING BEAMS AND (C) SPATIAL FREQUENCIES

(A) Diffraction efficiencies (%)			
0.3 mM	0.4 mM	0.5mM	
4.875	7.375	11.12	

(B) Diffraction efficiencies (%)	
50:50	70:30
3.75	2.81

(C) Diffraction efficiencies (%)			
10 ⁰	20 ⁰	30 ⁰	40 ⁰
1.87	4.06	3.43	2.37

IV. CONCLUSION

Acid Fuchsin dye doped polymer films were found to be good media for recording. It is observed that the formation of gratings strongly depend on the concentration of dye in the polymer film, the intensity ratios of the writing beams and the angle between the writing beams. Efficient writing can be made at an angle of 20⁰ and when the intensity ratio of the writing beams is unity. The diffraction efficiency of the grating is the ratio of the intensity of the first order diffracted power to the incident read beam power. Diffraction efficiencies of Acid Fuchsin doped polymers at different concentrations have been calculated. The diffraction efficiency of the grating is found to remain unchanged even after a storage period of several years.

REFERENCES

- [1] A. J. Kiran, K. Chandrasekharan, S. R. Nooji, H. D. Shasikala, G. Umesh, B. Kalluraya, Chem. Phys. 324, 699 (2006).
- [2] M. Chen, L. Yu, L.R. Dalton, Y.Q. Shi, W.H. Steier, Macromolecules 24, 5421 (1991).
- [3] Hari Singh Nalwa, Appl. Organometallic Chem. 5, 349 (2004).
- [4] C. Sanchez, B. Lebeau, F. Chaput, J.-P. Boilot, Adv. Mat. 15, 1969 (2003).

- [5] Y. He, X. Wang, Q. Zhou, Polymer 43, 7325 (2002).
- [6] M. D. Alam, T. Ohmachi, T. Ogata, T. Nonaka, S. Kurihara, Opt. Mat. 29, 365 (2006).
- [7] T. Hattori, T. Shibata S. Onadera, T. Kaino, J. Appl. Phys. 87, 3240 (2000).
- [8] K.G. Yager, C.J. Barrett, J. Chem. Phys. 120, 1089 (2004).
- [9] A. Costela, I. Garcia-marino, J. M. Figuera, et al., Opt. Commun. 130, 44 (1996).
- [10] Vinitha G. and Ramalingam A., Spectrochimica acta part A: Molecular and Biomolecular Spectroscopy, 69, 1160-1164 (2008).
- [11] Y.Nooraldeen, P.Delphia Shalini Rosalyn, P.Kannan, A.P. Mangayarkarasi, and P.K.Palanisamy, J. Optoelectronics and Advanced Materials, 12, 3368 – 3376 (2008).