

Conversion of Mechanical Water Pump to Electric Water Pump for a CI Engine

K. Arunachalam, P. Mannar Jawahar

Abstract—Presently, engine cooling pump is driven by toothed belt. Therefore, the pump speed is dependent on engine speed which varies their output. At normal engine operating conditions (Higher RPM and low load, Higher RPM and high load), mechanical water pumps in existing engines are inevitably oversized and so the use of an electric water pump together with state-of-the-art thermal management of the combustion engine has measurable advantages. Demand-driven cooling, particularly in the cold-start phase, saves fuel (approx 3 percent) and leads to a corresponding reduction in emissions. The lack of dependence on a mechanical drive also results in considerable flexibility in component packaging within the engine compartment. This paper describes the testing and comparison of existing mechanical water pump with that of the electric water pump. When the existing mechanical water pump is replaced with the new electric water pump the percentage gain in system efficiency is also discussed.

Keywords—Cooling system, Electric water pump, Mechanical water pump.

I. INTRODUCTION

ENGINE combustion will leads to high temperature. This temperature are transferred to the engine parts namely piston, cylinder head, liners, valves, etc. This temperature will make the engine parts to expand thermally, results in thermal stresses. Also overheated engine may cease the engine. In order to prevent this damage, a cooling system is required. Thus the main objective of the cooling system is to maintain the operating temperature of the engine. Mostly, engines are cooled using liquid coolant (water + additives) that run through heat exchanger. Water may contain salt, chemical or sediment which block the coolant path and also may result in chemical damage to the engine. The efficiency of water cooled engines mainly depends upon heat exchange taking place between coolant and cylinder. The cooling system [1]-[5] will have a radiator to dissipate the heat from the coolant to atmosphere, fan to circulate the air to the radiator, centrifugal mechanical pump driven by the crankshaft to circulate the coolant, temperature control device to maintain the coolant temperature, pipes to circulate the water etc. Fig. 1 shows the existing cooling system in an engine.

II. MECHANICAL WATER PUMP

The coolant is circulated by a centrifugal pump driven by crankshaft. A centrifugal pump has an impeller which rotating

Dr. K. Arunachalam and Dr. P. MannarJawahar are with the Department of Automobile Engineering, Anna University, MIT Campus, Chennai 600 044, India (e-mail: karunachalam@annauniv.edu, ponmannarjawahar@gmail.com).

on a casing. The fluid will enter through the centre and exists through gap between casing wall and impeller. As impeller rotates, the velocity of fluid has both radial and tangential directions and also both pressure and velocity will increases. However, the various issues faced in mechanical water pump as listed in [6], [7] includes: variable speed is not possible, switching on / off at required amount of time is not possible, increased power loss, increased fuel consumption. Mechanical water pump work with constant flow rate (i.e. flow rate cannot be varied) and variable heat transfer rate. During cold and warm up conditions, there is no need for cooling but since the mechanical water pump is permanently driven, power loss occurs and thus reduces the fuel efficiency. In order to overcome these limitations, it is proposed to convert the mechanical water pump into electrical water pump.

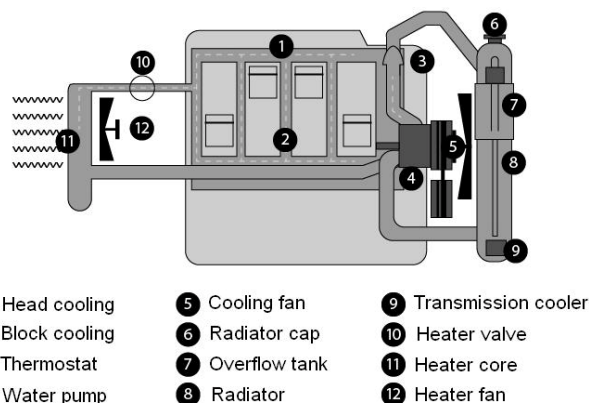

Fig. 1 Cooling System

III. METHODOLOGY

As discussed in the previous section, in order to overcome the limitations of a mechanical water pump, it is proposed to have the electrical water pump. To achieve this, the flow rate of the existing system is measured. Based on the experimental data, a suitable electric motor will be selected. This electric motor will be suitable on and off by the electronic control unit as per the control algorithm.

IV. MECHANICAL WATER PUMP TEST SETUP

The various assumptions made while running the test setup include: Engine is made to run at no load condition, the flow rate is measured at the engine outlet before going to the radiator, Thermostat valve is removed from the engine, bending losses are considered to be negligible. Fig. 2 shows the existing mechanical water pump present in the engine. Fig.

3 shows the test setup arrangement to test the mechanical water pump.



Fig. 2 Mechanical Water Pump

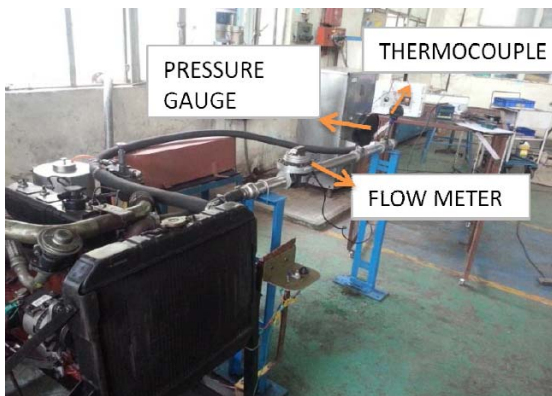

Fig. 3 Mechanical water pump test setup

The test procedure to test water pump has been discussed in [8], [9]. In this test setup, the engine is switched ON and made to run at different speeds. For the various speed of the engine fitted with mechanical water pump, the flow rates are determined. The pressure is found out both at water jacket as well as at the outlet of the engine after circulating inside the engine water jackets by fitting a pressure gauge and the graph plotting the same is shown in Fig. 4. For the engine with no load condition and corresponding water pump speed and head (calculated based on the pressure obtained) is shown in Fig. 5.

$$\text{Speed Ratio} = \frac{\text{Crank Shaft Pulley Diameter}}{\text{Water Pump Pulley Diameter}} = \frac{0.12}{0.086} = 1.4$$

The mechanical water pump speed is determined with the help of belt ratio (i.e.) 1.40 so that for different mechanical pump speeds, different mechanical pump power can be obtained as shown in the above calculation. For example, when the engine speed is 1500 rpm, then pump speed will be 2100 rpm. To know about the operation on pumps, knowledge on system curve and pump performance curve is necessary.

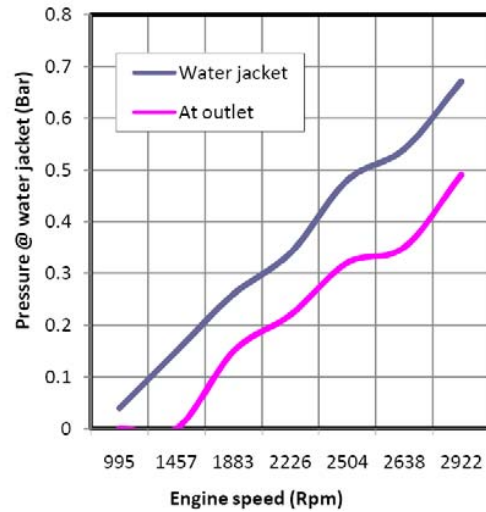

Fig. 4 Engine Speed Vs Pressure

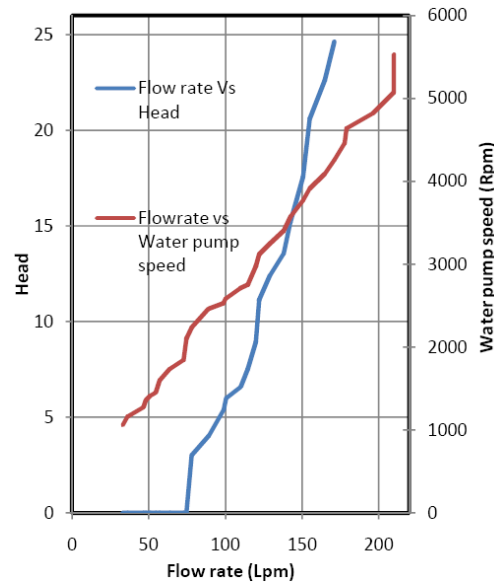

Fig. 5 Flow rate Vs Head/Water pump speed

Fig. 6 denotes a typical system curve which goes on increasing as the flow increases. But a typical pump performance curve denotes a decrease in flow rate as the head increases. By using Bernoulli's equation, system curve can be generated. The system curve provides the required head for the given flow rates. As flow rate increases, head required will increase to overcome losses and frictional forces. Best Efficiency Point (BEP) of the pump is the point in which operating point and pump curve intersects. In this test setup, the water pump isolated from the engine and coupled to a motor is made to run and a characteristic pump curve obtained is shown in Fig. 7.

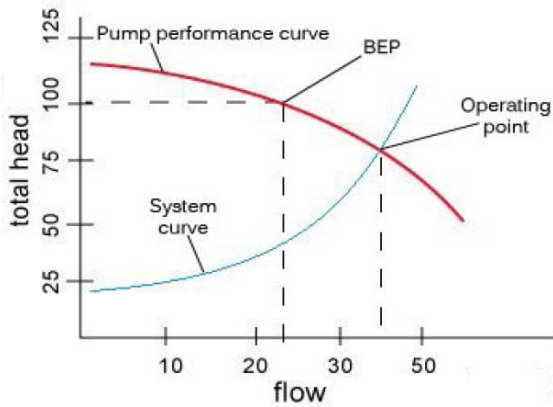

Fig. 6 System Curve

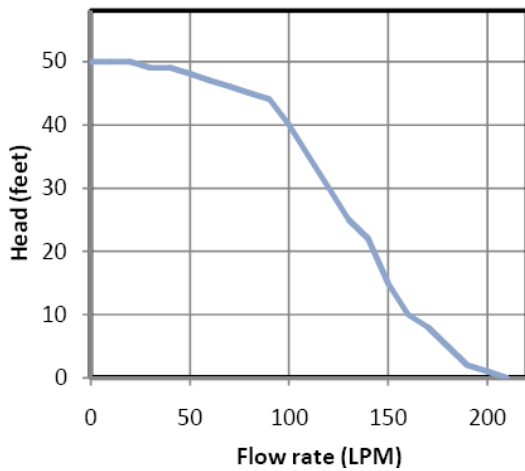

Fig. 7 Flow rate Vs Head

From the system and pump characteristics, it can be derived that as flow rate increases, the friction will increase and hence the pump supply less pressure. When the friction is equal to the pump pressure, there will not be further increase in pump pressure. Fig. 8 shows the plot of system curve and pump curve. From the Fig. 8, the actual performance for the pump is the point where system curve and pump curve intersects. The obtained values are indicated in Table I.

TABLE I
CALCULATED VALUES

Parameter	Value
Flow rate	145 LPM
Head	16 Feet
Pump power	284.49 W
Pump speed	3650 rpm
Engine power	632.2 W
Engine Speed	2517 rpm

Electric Motor is coupled with the pump, so that the pump speed and the motor speed become equal. Flow rate is kept constant at 145 LPM. Though the engine speed increases, the electrical water pump speed is kept constant at this will be required to deliver a flow rate of 145 LPM which has been

determined as the maximum cooling efficiency point from the above conducted experiments.

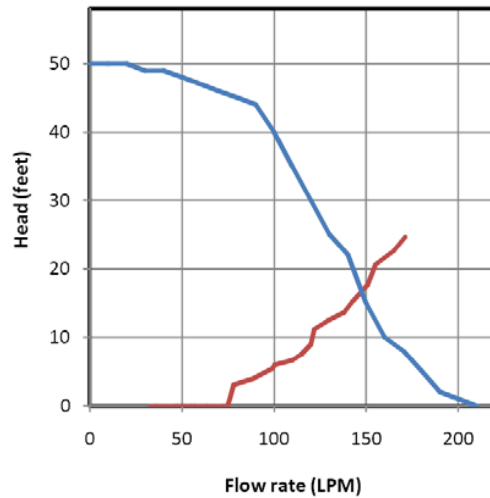

Fig. 8 Flow rate Vs Head/Water pump speed

V.ELECTRICAL WATER PUMP

The concept of electrical water pump has been analyzed by various researchers [10]-[15]. From the power consumption point of view, it is necessary to maximize the hydraulic efficiency. The same problem lies in mechanical pumps and researchers has developed volute design and an advanced impeller. This advanced system has improved over the existing theoretical data. Fig. 9 denotes a typical block diagram of a cooling circuit using an electric water pump.

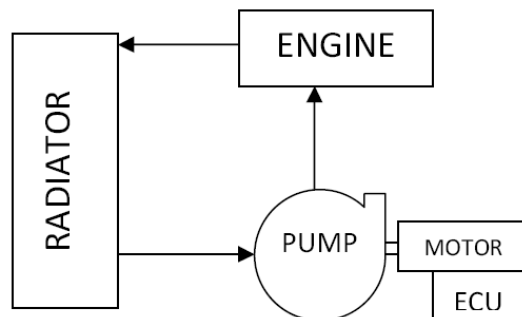

Fig. 9 Block diagram of cooling circuit

Several motors were thought to drive water pump. For the given design requirement, a brushless DC motor along with the controller is used. Brushless DC motor is preferred sine it has efficiency of about 90% and it ensures the overall cooling efficiency to be maximum. The motor is connected to the pump and so the motor torque gets decreased as the Motor speed increases. The experiments had been performed and the motor speed and motor torque is shown in Fig. 10.

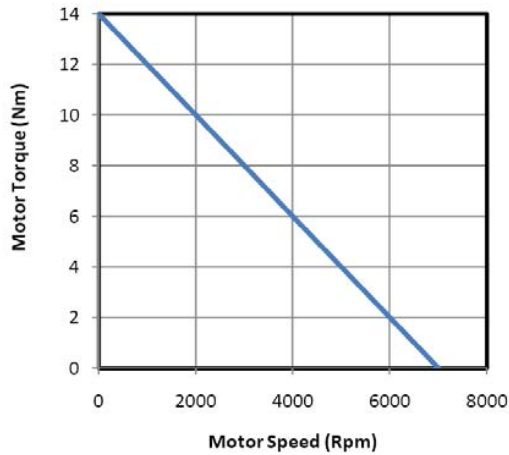

Fig. 10 Motor speed Vs Motor torque

The effectiveness of cooling system depends on the control strategy used [16]. In this work, control strategy to control the pump speed was developed based on the following criterion:

1. During start up and warm up conditions, only a nominal flow is required for circulation to keep engine temperatures even. In this condition, no cooling is required.
2. To achieve the desired heat rejection, during fully warmed up steady state condition, the system should use minimal coolant flow from the engine.
3. Run-on facility after key-off is incorporated to permit the control of heat soak.
4. It is designed to achieve satisfactory heat transfer rates.

VI. CONCLUSION

There are many limitations in present mechanical cooling system. In order to overcome the limitations, an electric cooling system has been proposed. In this system, a brushless DC motor has been selected and it will be driving the engine coolant pump. The pump will be switched on based on the control algorithm. From the experiments, it is determined that the average power required to drive the mechanical water pump is 669.29 W and when the same has been driven by electric water pump, the average power required to drive the motor is only 315.92 W. This leads to a gain in system efficiency, decreased power loss, increased fuel efficiency and enhanced cooling system.

REFERENCES

- [1] John Moffat, Chris James Leck, "Cooling systems", U.S. Patent No: US78408165B2, Apr 2, 2013.
- [2] Eric Andris, Bob Lindsay, "Cooling system", U.S. Patent No: US833172B2, Dec 18, 2012.
- [3] John Moffat, Chris James Leck, "Cooling systems", U.S. Patent no: US8291870B2, Oct 23, 2012.
- [4] Franco Cimmatti, Fabrizio Faverretto, "Cooling system for a vehicle with hybrid propulsion", U.S. patent no: US8281882B2, Oct 9, 2012.
- [5] Tonye. K. Jack, Mohammed M. Ojapah, "Water-cooled petrol engines: a review of considerations in cooling systems calculations with variable coolant density and specific heat", International Journal of Advances in Engineering & Technology, Vol. 6, Issue 2, pp. 659-667, May 2013.

- [6] Ronald F.Cline, Antonio Vespa, "Series Electric-Mechanical Water pump system for engine cooling", U.S. Patent no: US8196553B2, June 12, 2012.
- [7] Thomas G. Lawrence, Gregg T. Black, "Mechanically driven centrifugal air compressor with hydrodynamic thrust load transfer", U.S. Patent No: 5425345, June 20, 1995.
- [8] Osamu Shintani, Shinichi Hamada, "Cooling apparatus and cooling method for internal combustion engine", U.S. Patent no: US8342142B2, Jan 1, 2013.
- [9] Kazuya Nakagaki, Hiroshi Kobae, "Engine coolant amount determining apparatus", U.S. Patent no: US8292499B2, Oct 23, 2012.
- [10] Seung Yong Lee, Gyuhan Kim, "Electric Water Pump", U.S. Patent No: US8562314B2, Oct 22, 2013.
- [11] Seok Kim, Yong sun park, "Electric water pump with moulded circuit board with hall sensor", U.S. Patent No: US8304939B2, Nov 6, 2012.
- [12] Seung Yong Lee, Gyuhan Kim, "Electric Water Pump", U.S. Patent no: US2011/0115313 A1, May 19 2011.
- [13] Verle Propst, Rochester Hills, "Ram Air Electric drive Water Pump", U.S. Patent no: 5279503, Jan 18, 1994.
- [14] Josph Paliwoda, West bloomfield, "Electric Drive Water pump", U.S. Patent no: 5275538, Jan 4, 1994.
- [15] Richard J Smith, Jr., Middleburg, "Electric Water Pump", U.S. Patent no: 4215568, Aug 5, 1980.
- [16] Brace C.J. et al., "Integrated Cooling Systems for Passenger Vehicles", SAE 2001.