

Stress Analysis of the Ceramics Heads with Different Sizes under the Destruction Tests

V. Fuis, P. Janicek, T. Navrat

Abstract—The global solved problem is the calculation of the parameters of ceramic material from a set of destruction tests of ceramic heads of total hip joint endoprosthesis. The standard way of calculation of the material parameters consists in carrying out a set of 3 or 4 point bending tests of specimens cut out from parts of the ceramic material to be analysed. In case of ceramic heads, it is not possible to cut out specimens of required dimensions because the heads are too small (if the cut out specimens were smaller than the normalised ones, the material parameters derived from them would exhibit higher strength values than those which the given ceramic material really has). A special destruction device for heads destruction was designed and the solved local problem is the modification of this destructive device based on the analysis of tensile stress in the head for two different values of the depth of the conical hole in the head. The goal of device modification is a shift of the location with extreme value of σ_{1max} from the region of head's hole bottom to its opening. This modification will increase the credibility of the obtained material properties of bioceramics, which will be determined from a set of head destructions using the Weibull weakest link theory.

Keywords—Ceramic heads, depth of the conical hole, destruction test, material parameters, principal stress, total hip joint endoprosthesis.

I. INTRODUCTION

MATERIAL properties of bioceramic material are usually determined by standard 3 or 4-points bending tests [26] using the Weibull weakest link theory [13], [15]. This method is useful when samples cut out of the ceramic part guarantee the standardized minimum dimensions. If the sample dimensions are smaller than those given by standards, they show material characteristics of higher values than in reality. This phenomenon is due to the fact that with a decreasing sample volume the probability of a critical length crack decreases; this, under a given stress state, causes a sample

V. Fuis is with the Centre of Mechatronics, Institute of Thermomechanics Academy of Sciences of the Czech Republic and Institute of Solid Mechanics, Mechatronics and Biomechanics, Faculty of Mechanical Engineering, Brno University of Technology, Brno, Czech Republic, Technicka 2, 616 69 Brno, Czech Republic (phone: +420 541142891; fax: +420 541142876; e-mail: fuis@fme.vutbr.cz).

P. Janicek is with the Centre of Mechatronics, Institute of Thermomechanics Academy of Sciences of the Czech Republic and Institute of Solid Mechanics, Mechatronics and Biomechanics, Faculty of Mechanical Engineering, Brno University of Technology, Brno, Czech Republic, Technicka 2, 616 69 Brno, Czech Republic (phone: +420 541142807; fax: +420 541142876; e-mail: premysl.janicek@gmail.com).

T. Navrat is with the Institute of Solid Mechanics, Mechatronics and Biomechanics, Faculty of Mechanical Engineering, Brno University of Technology, Brno, Czech Republic, Technicka 2, 616 69 Brno, Czech Republic (phone: +420 541142861; fax: +420 541142876; e-mail: navrat@fme.vutbr.cz).

fracture [24], [25].

The material parameters of the real bioceramics are very important because the designer can improve the design of the implant and increase its reliability. Fig. 1 shows an example of *in vivo* destruction of the ceramic head of total hip joint endoprosthesis. The austenitic stem is significantly plasticized by the action of the destructed head [22].



Fig. 1 *In vivo* destructed ceramic heads of total hip joint endoprosthesis

II. METHODS

A global objective is to determine the material properties of bioceramics, from which hip replacement heads are manufactured. This hip replacement is attached to the stem taper and loaded on its spherical surface by contact pressure of the cup [23]. This method of loading shows variations and it depends on the physiology of the individual patient and on the process of patient's physical activity. Therefore, for the destruction test, we prefer the load used to test the static strength of ceramic heads ISO 7206-5 – Fig. 2 [3], [18]. During this test, the head is pressed on the stem in the direction of the system axis and thus the created character of stress state is suitable for both the assessment of head static strength and also for determination of material properties. In the process of solving the stress state in the ceramic head of total hip replacement loaded according to ISO 7206-5, it was found out that the stress state in the head is heavily dependent on micro and macro shape deviations of tapered contact surfaces [1], [7], [9], [14], [17], [21]. The different value of the angle of the head's and stems's cone (angle α – Fig. 2) is assumed as macroshape deviations of the contacted cones. The micro shape deviations of the cones are shown on Fig. 3 and

the values are in μm . Therefore this loading of the head is not acceptable for determination of the material parameters of used bioceramics.

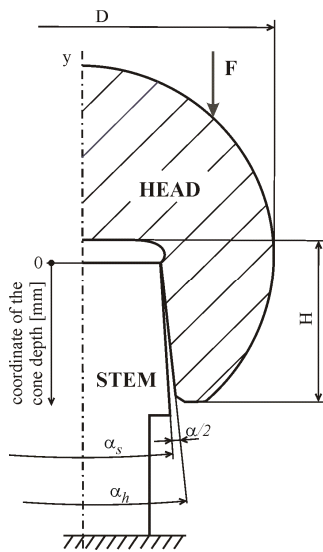

Fig. 2 Topology and loading under ISO 7206-5 loading – macroshape deviations of the system [2]

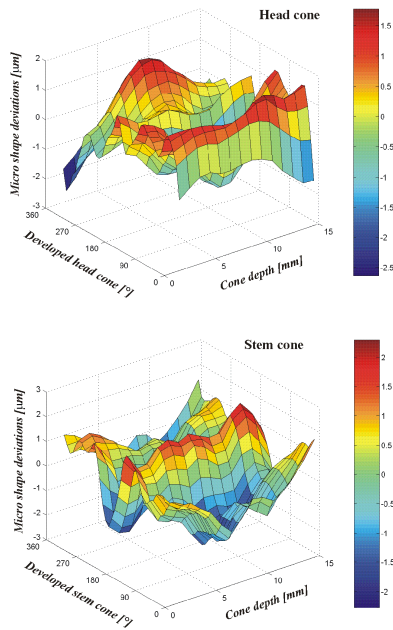

Fig. 3 Measured microshape deviations of the head's and stem's contact cone areas [8]

Another type of the loading of the heads with the similar stress states as above is shown in Fig. 4 for two types of the head (different value of the depth of the conical hole). The head's hole is loaded only by the pressure and the tensile stress in the head is therefore not influenced by the macro and micro shape deviations because the contact of the cones is not realized.

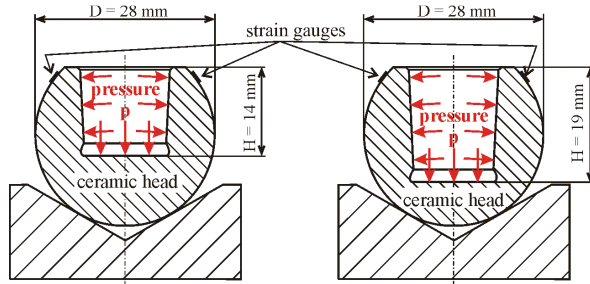

Fig. 4 Scheme of the loading of the heads with different value of H (14 mm and 19 mm)

When destructing the head, it is necessary to know the value of tensile strain in order to subsequently determine the stress field. Therefore, two strain gauge transducers (about 1 mm from the edge – Fig. 4) are bonded on the outer surface of the spherical area; these transducers measure circumferential strain of the head under pressure loading [11], [16], [20].

The entire head is in a special destructive device and the pressure load is exerted by a piston which acts on the rubber disposed in a tapered hole of the head. Rubber acts on the head by internal pressure p ; this causes the circumferential tensile strain in the head to destroy it subsequently.

Typical isosurfaces of the first principal stress σ_1 in the head under a given pressure load are described in Fig. 5 [6], [9]. This figure shows that the maximum value of σ_1 (379 MPa) is at the transition region of the tapered hole into its bottom (region A) and is dependent on the radius of this transition r . After the destruction of each head, it is possible to measure the specific value of the radius and to determine the stress field for specifically measured radius. However, for destruction of 40 heads, this method is time-consuming and computational methodology of material characteristics specified in [5], [10] is also more complicated. Therefore, efforts have been made to eliminate the stress concentration at the transition region of the taper into the region B (Fig. 5).

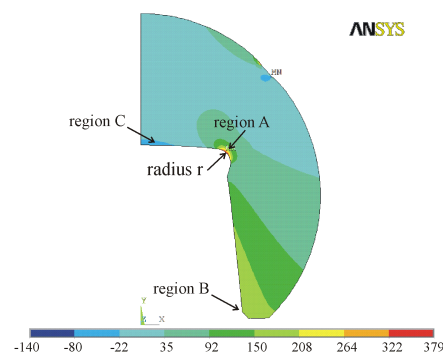

Fig. 5 The first principal stress in the head in MPa [19]

One of the options how to eliminate the stress concentration in the region A is to prevent the pressure acting in the transition region of the taper (region A). A metal plate (pad) with a trapezoidal cross-section is inserted into the region of

the head bottom, as shown in Fig. 6 (thickness $t = 2$ mm). The pressure of rubber acts on a pad with a diameter $d = 12$ mm. This pad is in the contact with the head bottom only on the diameter d_1 , which can vary. The aim of the analysis is to determine for which diameter d_1 the maximum value of σ_1 in the head will move out of stress concentrator.

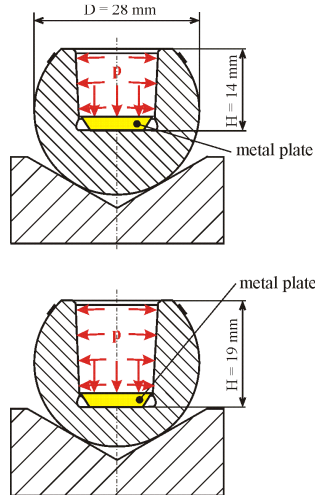

Fig. 6 Scheme of the loading of the heads with the metal plate

Computational modelling is performed using the finite element method - ANSYS. Due to the axis symmetry of the analyzed body, the head is discretized by axis symmetric elements. A bond on the spherical surface is modelled as rigid and pressure load is applied to the inner hole of the head - pressure $p = 100$ MPa acts on the whole tapered part (including the hole termination); pressure p_1 acts in the contact region with the pad - Fig. 6. The value of pressure p_1 is determined from the force balance of trapezoidal pad in the axial direction.

In terms of head geometry it is a variant with an outer diameter of 28 mm, taper of 12/14 mm and two variants of the hole depth (Fig. 6). This type of head has been destroyed by a special destructive device described in greater detail in [11]. The head is made of bioceramics Al_2O_3 characterised by the value of modulus of elasticity $E = 3.9$ GPa and Poisson's ratio $\mu = 0.23$ [4], [12].

III. RESULTS AND DISCUSSION

The nominal value of the maximal value of σ_1 in region B is 208 MPa [11] - we can try to reduce the maximal stress in the region A under this value. Isosurfaces of the first principal stress in the head for pad different diameter d_1 are shown in Figs. 7 and 8 (Fig. 7 shows head with $H = 14$ mm and Fig. 8 is for head with $H = 19$ mm). With a decreasing size of diameter d_1 , the maximum stress is still located in the region A (Fig. 5) and it almost always obtains extreme values of about 280 - 290 MPa for head with $H = 14$ mm. The similar situation is for variant with $H = 19$ mm, only the extreme values of σ_1 are significantly higher (about 415 - 435 MPa - Fig. 8).

Maximum tensile stress for small value of d_1 (about value 2.8 mm) is shifted to the region C (Fig. 5) due to the high pressure p_1 .

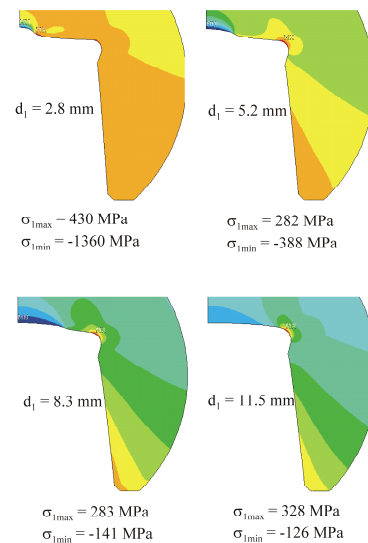

Fig. 7 Isosurface of stress σ_1 for different values of the pad diameter d_1 ($H = 14$ mm, $d = 12$ mm, $p = 100$ MPa)

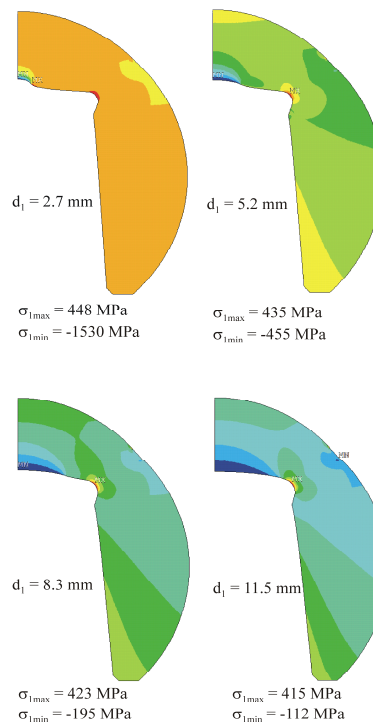

Fig. 8 Isosurface of stress σ_1 for different values of the pad diameter d_1 ($H = 19$ mm, $d = 12$ mm, $p = 100$ MPa)

The analysis shows that in this case it is not possible to achieve the elimination of effects of stress concentration in the transition region of the taper into the head bottom (region A).

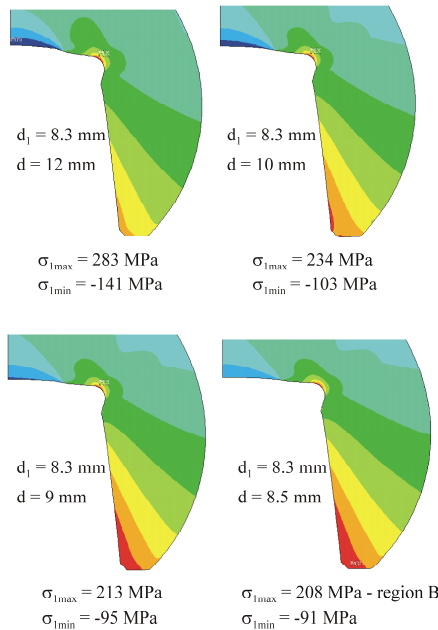

Fig. 9 Isosurface of stress σ_1 for different values of the pad diameter d ($H = 14$ mm, $d_1 = 8.3$ mm, $p = 100$ MPa)

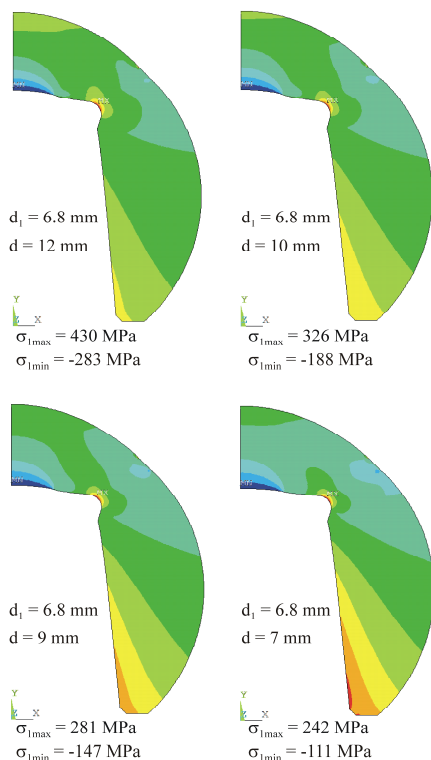

Fig. 10 Isosurface of stress σ_1 for different values of the pad diameter d ($H = 19$ mm, $d_1 = 6.8$ mm, $p = 100$ MPa)

Now there is a possibility to determine for a given diameter d_1 the value of diameter d so that the maximum stress is shifted from the transition region of the taper into the head bottom. The size of diameter d_1 was selected 8.3 mm for head

with $H = 14$ mm and Fig. 9 shows the isosurfaces of σ_1 for different pad diameter d_1 (12; 10; 9 and 8.5) mm with corresponding pressure p_1 . Fig. 10 shows the same as Fig. 9 but for head with $H = 19$ mm. The results of computational modelling suggest that for the pad having a diameter $d_1 = 8.3$ mm and the diameters $d < 8.8$ mm, the position of maximum stress has shifted from the hole bottom region (region A) to its opening (region B), as shown in Fig. 9.

Different situation is for the head with $H = 19$ mm (Fig. 10). The maximum tensile stress is reduced (from 430 MPa to 242 MPa – Fig. 10) with the reduction of the diameter d but for limit value of the d ($d = 7$ mm and $d_1 = 6.8$ mm) the maximal value of σ_1 is still located in region A – it is caused by the lower bending stiffness of the head with $H = 19$ mm than head with $H = 14$ mm.

IV. CONCLUSION

The aim of this study was to change the way of destroying the heads so that the position of extreme values of tensile stresses has moved from the is with the region of the head bottom (region A) to its opening (region B). To achieve this goal it is necessary to insert a trapezoidal pad into the head, which will change the pressure acting in the region of head bottom. However, this arrangement is not applicable to all variant of the heads – in our case for the head with $H = 19$ mm.

ACKNOWLEDGMENT

This work is an output of research and scientific activities of NETME Centre, regional R&D centre built with the financial support from the Operational Programme Research and Development for Innovations within the project NETME Centre (New Technologies for Mechanical Engineering), Reg. No.CZ.1.05/2.1.00/01.0002 and, in the follow-up sustainability stage, supported through NETME CENTRE PLUS (LO1202) by financial means from the Ministry of Education, Youth and Sports under the „National Sustainability Programme I“ and is supported by the project of the Czech Science Foundation GA CR nr. 13-34632S – Increasing the level of computational modelling of the behaviour of the ceramic hip joint for total hip joint endoprosthesis.

REFERENCES

- [1] A. O. Andrisano, E. Dragoni and A. Strozzi, “Axisymmetric mechanical analysis of ceramic heads for total hip replacement,” in *Proc. Inst. Mech. Engrs*, Part H, vol. 204, pp. 157-167, 1990.
- [2] V. Fuis and P. Janicek, “Stress and reliability analyses of damaged ceramic femoral heads,” in *Conf. on Damage and Fracture Mechanics*, Maui Hawaii, Structures and Materials vol. 12, pp. 475-485, 2002.
- [3] W. Weisse, M. Zahner, W. Weber and W. Rieger, “Improvement of the reliability of ceramic hip joint implants,” *J. of Biomechanics* 36, pp. 1633-1639, 2003.
- [4] V. Fuis, M. Koukal and Z. Florian, “Shape Deviations of the Contact Areas of the Total Hip Replacement,” in *Proc. 9th Inter. Conf. on Mechatronics*, Warsaw, Poland pp. 203-212, 2011.
- [5] D. Bush, “Designing Ceramic Components for Structural Applications,” *J. Mater. Eng. Perf.* ASM Int., vol. 2, pp. 851-862, 1993.

- [6] V. Fuis, M. Malek and P. Janicek, "Probability of destruction of Ceramics using Weibull's Theory," in *Proc. 17th Inter. Conf. on Engineering Mechanics 2011*, Svratka, Czech Rep., pp. 155-158.
- [7] S. H. Teoh, W. H. Chan and R. Thampuran, "An Elasto-plastic Finite Element Model for Polyethylene Wear in Total Hip Arthroplasty," *J Biomech* 35: 323-330, 2002.
- [8] V. Fuis, P. Janicek and L. Houfek, "Stress and Reliability Analyses of the Hip Joint Endoprosthesis Ceramic Head with Macro and Micro Shape Deviations," in *Proc. Inter. Conf. on Biomedical Engineering*, Singapore, *IFMBE Proc.* vol. 23, iss. 1-3, pp. 1580-1583, 2008.
- [9] V. Fuis, "Stress and reliability analyses of ceramic femoral heads with 3D manufacturing inaccuracies," in *Proc. 11th World Congress in Mechanism and Machine Science*, Tianjin, China pp. 2197-2201, 2004.
- [10] A. F. McLean and D. L. Hartsock, *Engineered materials handbook*, vol. 4, Ceramics and Glasses. ASM International, pp. 676-689, 1991.
- [11] V. Fuis, T. Navrat, et al., "Reliability of the Ceramic Head of the Total Hip Joint Endoprosthesis Using Weibull's Weakest-link Theory", in *IFMBE Proc.* vol. 14, World Congress on Medical Physics and Biomedical Engineering, Seoul, South Korea pp. 2941-2944, 2006.
- [12] V. Fuis, "Tensile Stress Analysis of the Ceramic Head with Micro and Macro Shape Deviations of the Contact Areas," in *Recent Advances in Mechatronics: 2008-2009, Proc. Inter. Conf. on Mechatronics*, Brno, Czech Rep., pp. 425-430, 2009.
- [13] R. Jiang and D. N. P. Murthy, "A study of Weibull shape parameter: Properties and significance." *Reliability Engineering and System Safety* 96, pp. 1619-1626, 2011.
- [14] V. Fuis and J. Varga, "Stress Analyses of the Hip Joint Endoprosthesis Ceramic Head with Different Shapes of the Cone Opening," in *Proc. 13th Inter. Conf. on Biomedical Engineering, IFMBE Proc.*, vol. 23, iss. 1-3, pp. 2012-2015, 2009.
- [15] B. Basu, D. Tiwari, D. Kundu and R. Prasad "Is distribution the most appropriate statistical strength distribution for brittle materials?" *Ceramics International*, vol. 35, iss. 1, pp. 237-246, 2009.
- [16] V. Fuis, T. Navrat and P. Vosynek, "Analyses of the Shape Deviations of the Contact Cones of the Total Hip Joint Endoprostheses," in *Proc. 6th World Congress of Biomechanics (WCB 2010)* Singapore, Series: *IFMBE Proc.* vol.: 31, pp. 1451-1454, 2010.
- [17] V. Fuis and P. Janicek, "Stress and reliability analyses of ceramic femoral heads with axisymmetric production inaccuracies," in *Proc. 9th Mediterranean Conference on Medical and Biological Engineering and Computing*, Pula, Croatia, Series: *IFMBE Proc.* Pts. 1 and 2, pp. 632-635, 2001.
- [18] G. Willmann, "The principle of taper fitting of ceramic articular heads of hip joint endoprostheses," Internal Report, CERASIV GmbH, Plochingen, Germany, 1993.
- [19] P. Janicek, "Stress-strain analysis of ceramic heads in the destruction device," in *Proc. 20th Inter. Conf. Engineering Mechanics 2014*, Svratka, Czech Republic, pp. 260-264.
- [20] V. Fuis and P. Janicek, "Calculation of the bio-ceramic material parameters," in *Proc. 10th Inter. Conf. on Mechatronics 2013*, Czech Republic, pp. 855-861.
- [21] V. Fuis, M. Koukal and Z. Florian, "Shape deviations of the contact areas of the total hip replacement," in *Proc. 9th Inter. Conf. on Mechatronics 2011*; Warsaw, Poland, pp. 203-212.
- [22] F. Šebek, J. Hůlka, P. Kubík and J. Petruška, "On the proportionality of damage rule in finite element simulations of the ductile failure," *Advanced Materials Research*, 980, pp. 189-193, 2014.
- [23] M. Vrbka, T. Navrat, et al., "Study of film formation in bovine serum lubricated contacts under rolling/sliding conditions," in *Proc. of the Institution of Mechanical Engineers, Part J: Journal of Engineering Tribology*, 227 (5), pp. 459-475, 2013.
- [24] I. Janů, J. Kočíš, T. Návrát, Z. Florian, P. Wendsche., "A comparative analysis of socon CS and socon pedicle screws in view of their use for treatment of osteoporotic fractures of the thoracolumbal spine. a biomechanical study," *Acta Chirurgiae Orthopaedicae et Traumatologiae Cechoslovaca*, 78 (4), pp. 334-338, 2011.
- [25] I. Cizmar, Z. Florian, T. Navrat, D. Palousek, "A biomechanical study of a suture between the deltoid muscle and a free tendon graft for reconstruction of the elbow extension," *Biomedical Papers*, 155 (1), pp. 79-84, 2011.
- [26] L. Urbanová, R. Smec, P. Proks, L. Stehlik, Z. Florian, T. Návrát, A. Nečas, "Comparison of the resistance to bending forces of the 4.5 LCP plate-rod construct and of 4.5 LCP alone applied to segmental femoral defects in miniature pigs," *Acta Veterinaria Brno*, 79 (4), pp. 613-620, 2010.