

# Battery/Supercapacitor Emulator for Chargers Functionality Testing

S. Farag, A. Kupeman

**Abstract**—In this paper, design of solid-state battery/supercapacitor emulator based on dc-dc boost converter is described. The emulator mimics charging behavior of any storage device based on a predefined behavior set by the user. The device is operated by a two-level control structure: high-level emulating controller and low-level input voltage controller. Simulation and experimental results are shown to demonstrate the emulator operation.

**Keywords**—Battery, Charger, Energy, Storage, Supercapacitor.

## I. INTRODUCTION

THE developments in the field of supercapacitors and batteries have made them a viable alternative to other energy storage technologies. These devices possess high charging and discharging power capabilities, long shelf/cycle life and wide temperature range operation. Electrochemical energy storage devices have been employed in a variety of applications, e.g. electric, hybrid electric and fuel cell vehicles and public transportation [1]–[8]. When utilized in transportation applications, the majority of batteries/supercapacitors charging take place at charging stations [9]. In general, when no primary energy source is present in the system, batteries and supercapacitors must be recharged externally by dedicated chargers [10]. Testing of such a charger (which is a complicated intelligent system) should be carried out under both nominal and boundary conditions, which may be unachievable when a real battery is connected. Moreover, frequent cycling performed during charger testing may reduce battery life. The relatively high price of Lithium batteries and supercapacitors must be taken into account as well since it may pose an obstacle to a low-budget educational laboratory, willing to test a charger under development. Real battery/ultracapacitor may be often replaced by a dedicated programmable electronic load, capable of operating as constant voltage/constant current sink. Nevertheless, such devices are pretty expensive, their bandwidth is limited and they possess a relatively high unknown input capacitance, which may influence the charger behavior. In this paper we propose a relatively low-cost design of a universal battery/supercapacitor emulator based on a dc-dc converter. The design may either be performed from scratch or utilize an off-the shelf power stage by combining with appropriate control circuitry. The rest of the paper is as follows. The system-level view of the proposed emulator is presented in Section II. High and low level controllers are revealed in

Sections III and IV, respectively. Sample simulation and experimental results are demonstrated in Section V. The paper is concluded in Section VI.

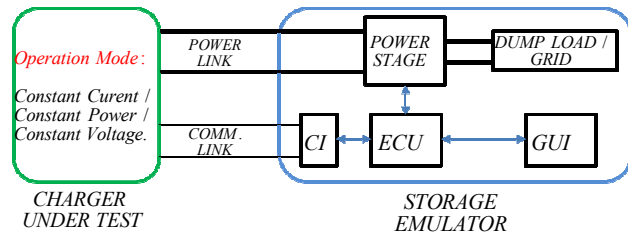

Fig. 1 Charger-emulator connection topology

A typical charger-battery/supercapacitor connection diagram is shown in Fig. 1. There are two main links: power and communication (optional). The latter is absent in simple systems while inevitable in "smart" batteries and transportation-size modules and is usually implemented using SM-Bus, One-Wire or CAN-Bus protocol. In battery electric vehicles, the storage serves as master giving the requested charging power command to the charger, operating as slave [9]. Note that the charger must be capable of operating in constant power, constant current or constant voltage modes, utilized in charging sequences. In low power systems (e.g. laptop battery), the charger manages the charging process making sure (via communication link) that the battery is still present and functions properly. As mentioned above, an emulator should contain two main software modules as well as power conversion hardware. The charger interface (CI) module is responsible for either driving the charger with suitable command in case of master-slave operation or imitating typical battery signaling required for the charger to continue charging process. In order to be universal, the device must be able to receive the characteristics of emulated device from the user via graphical user interface (GUI). These characteristics are then passed to an electronics control unit (ECU), which executes a two-level control structure (Fig. 2): the upper level controller (ULC) generates input voltage/current reference of the power stage, "seen" by the charger (voltage in case of constant current or constant power charging; current in case of constant voltage charging); the lower level controller (LLC) ensures that actual power stage input follows the reference. Note that the energy injected into the emulator by the charger is not actually stored and must be either dissipated on a dump load or pushed back into the grid.

S. Farag and A. Kupeman are with the Hybrid Energy Sources R&D Laboratory, Ariel University, Ariel 40700 Israel, (e-mail: shashikiko@gmail.com, alonku@ariel.ac.il).

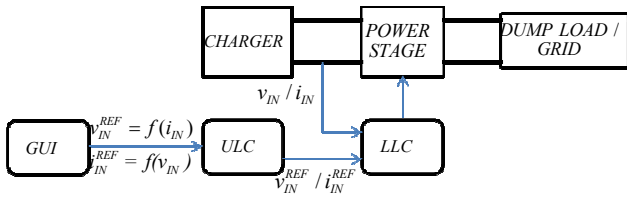

Fig. 2 Emulator control structure

II. DESIGN METHODOLOGY

Consider the low-frequency model of a charging supercapacitor, shown in Fig. 3, composed of the Equivalent Series Resistance (ESR)  $R$  of the capacitor  $C$  along with initial internal capacitance voltage. The circuit is governed by the following equation (suitable for constant current and constant power charging modes),

$$v(t) = R \cdot i(t) + \frac{1}{C} \int i(t) dt + v_c(0). \tag{1}$$

In case  $R$ ,  $C$  and  $v_c(0)$  are set by the user (note that  $R$  and  $C$  may be changed "on the fly" as a function of terminal voltage and device temperature, as in a real supercapacitor), the upper level controller will generate a power stage input voltage command according to (1). If the power stage input voltage follows the reference, the charger will "see" a supercapacitor connected to its terminal. In case of emulating a battery with a given charging profile (e.g. Fig. 5), the device output characteristics are given by

$$v(t) = R \cdot i(t) + LUT \left( \int i(t) dt \right) + v_B(0). \tag{2}$$

where  $R$  is the ESR of the battery while  $v_B(0)$  states the initial internal battery voltage. The Look Up Table (LUT) denotes the relation between the absorbed charge (Ah) and internal battery voltage, derived from the charging profile. Again, if the power stage input voltage follows the reference, the charger will "see" a battery connected to its terminal.

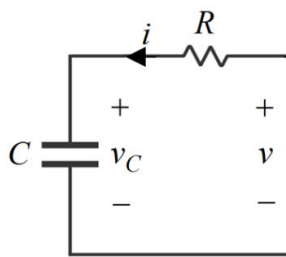

Fig. 3 Supercapacitor low-frequency equivalent circuit

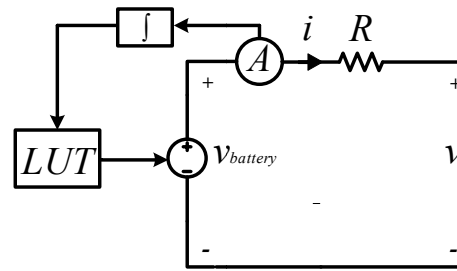

Fig. 4 Battery equivalent circuit

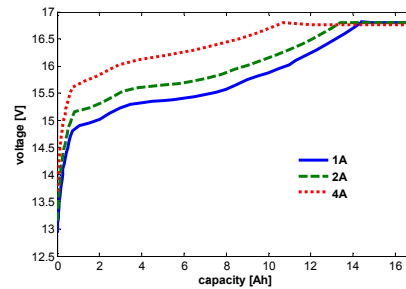

Fig. 5 Typical battery charging profile

III. EXAMPLE

A sample storage emulator is presented in Figs. 6 and 7, respectively. Power circuit is based on a boost dc-dc converter (charger is represented by a current source). The higher level controller senses the input current and generates voltage reference command based on (1) or (2). The lower level controller is implemented via a dual loop cascaded controller. The results were obtained as follows. First, experimental charging of a real device was performed. Then, emulated charging was simulated. Fig. 8 presents the results of 150W constant power charging of Maxwell 58F, 22mOhm supercapacitor, while Fig. 9 presents the results of 8A constant current charging of two Maxwell 58F, 22mOhm supercapacitors first at 116F, 11mOhm and during the charging changes to 58F, 220hm. Fig. 10 presents the results of 8A constant current charging of MR-2791 14.8V, 15.6 Ah Li-ion battery. Apparently, the results match extremely well, validating emulator design methodology

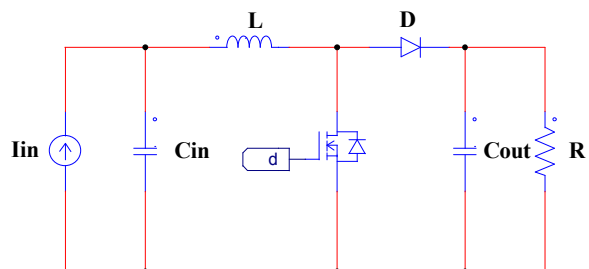

Fig. 6 Power circuit

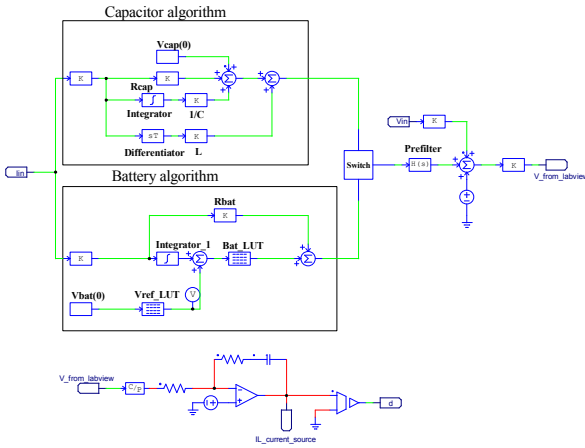

Fig. 7 Control circuit

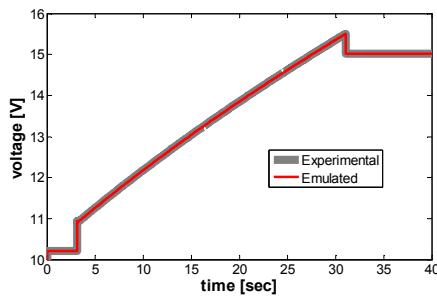

Fig. 8 Supercapacitor constant power charging

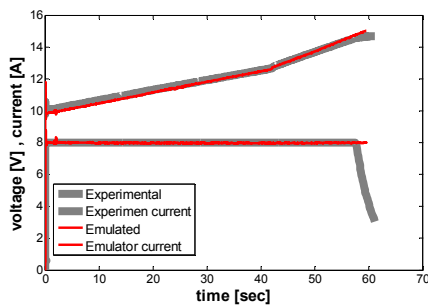

Fig. 9 Supercapacitor constant current charging with capacitance modification

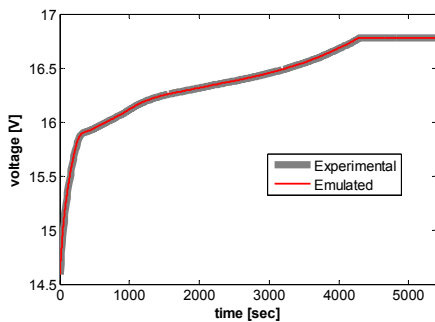

Fig. 10 Battery charging

## IV. DESIGN CONSIDERATIONS

The emulator consist of a dc-dc boost converter (150W step up 10-32V to 12-35V, 15A to 10A) with a load connected to the converters output to receive the energy from the converter during emulating capacitor/battery charge. In order to determine the required load for the selected charging range the following calculations were taken. First the minimum and maximum power was calculated according to the converter voltage characteristics and the current range 1A to 8A along with the power equation which is: power equals to voltage multiplied by the current,

$$\left. \begin{array}{l} V_{in}^{\min} = 10V \\ I_{in}^{\min} = 1A \end{array} \right\} P_{in} = 10W \quad (3)$$

$$\left. \begin{array}{l} V_{in}^{\max} = 18V \\ I_{in}^{\min} = 1A \end{array} \right\} P_{in} = 18W \quad (4)$$

$$\left. \begin{array}{l} V_{in}^{\min} = 10V \\ I_{in}^{\max} = 8A \end{array} \right\} P_{in} = 80W \quad (5)$$

$$\left. \begin{array}{l} V_{in}^{\max} = 18V \\ I_{in}^{\max} = 8A \end{array} \right\} P_{in} = 144W \quad (6)$$

Assuming the converter is ideal in order to simplify the calculations the input power equals to the output power. By knowing the converter output power and output voltage the required load was calculated,

$$R = \frac{V^2}{P}, \quad (7)$$

$$\left\{ \begin{array}{l} V_{out}^{\min} = 12V \\ V_{out}^{\max} = 34V \end{array} \right\}, P_{out} = 10W, \quad (8)$$

$$\left\{ \begin{array}{l} V_{out}^{\min} = 20V \\ V_{out}^{\max} = 34V \end{array} \right\}, P_{out} = 18W, \quad (9)$$

Applying (7) to (8) and (9) respectively the maximum load range is,

$$\left. \begin{array}{l} 14.4\Omega < R_{load} < 115.6\Omega \\ 22.22\Omega < R_{load} < 64.22\Omega \end{array} \right\} 22.22\Omega < R_{load} < 64.22\Omega \quad (10)$$

$$\left\{ \begin{array}{l} V_{out}^{\min} = 12V \\ V_{out}^{\max} = 34V \end{array} \right\}, P_{out} = 80W, \quad (11)$$

$$\left\{ \begin{array}{l} V_{out}^{\min} = 20V \\ V_{out}^{\max} = 34V \end{array} \right\}, P_{out} = 144W, \quad (12)$$

Applying (7) to (11) and (12) respectively the minimum load range is,

$$\left. \begin{aligned} 1.8\Omega < R_{load} < 14.45\Omega \\ 2.77\Omega < R_{load} < 8.027\Omega \end{aligned} \right\} 2.77\Omega < R_{load} < 8.027\Omega \cdot (13)$$

The same can be done for the entire current range from 1A to 8A. After calculating the entire range the selected loads for the emulated system are 8Ω and 25 Ω separately. The 25Ω load works between 1A to 2A and the 8Ω load works between 2A to 8A. By using those loads the converter is in the required voltage boundaries without entering to an over voltage mode which may cause the converter some problems such as capacitors overvoltage that can lead to an explosion. To apply the loads connection, a comparator connected to a D flip flop and then to the switch/relay is suggested Fig. 11 to switch between the loads when the output voltage reaches the predefined maximum value in this case 34V. The first connection mode is with the 25Ω load when the output voltage is above 34V the switch/relay switches to the 8Ω load. More over another comparator connected to a switch/relay is suggested for safety reasons to disconnect the emulator from the power supply when the output voltage is above 35V.

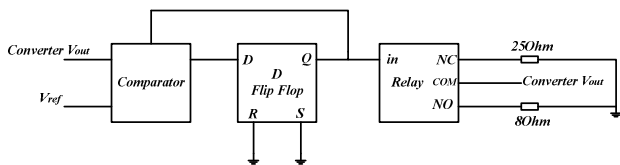

Fig. 11 Switch/relay for the two loads

V. APPLICATION

The system application was formed using a boost dc-dc converter, NI USB-6009 that sense the current and the initial voltage of the supercapacitor/battery from the dc-dc converter to generate the control signal that states the required voltage, NI Lab View GUI that control the NI USB-6009 and contains (1) and (2) in order to command the NI device which signal to send to the dc-dc converter in order to control the converters input voltage. Fig. 12 presents the emulator diagram in a close loop connection which contains the dc-dc converter, NI device and a computer with the NI Lab View software that control the NI device to generate the proper voltage control signal.

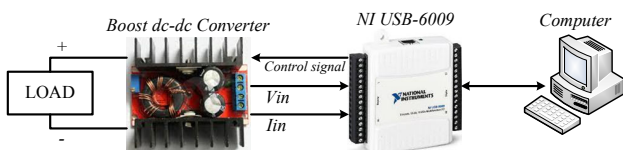

Fig. 12 Emulator diagram

The user can control the supercapacitor/battery parameters such as the initial voltage, ESR, capacitance, LUT for the battery according to the manufacture data using the GUI so that the emulation can mimic the supercapacitor/battery behavior as close as possible to reality Fig. 13 presents the GUI that the user control.

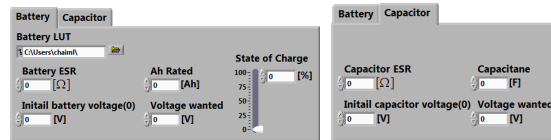

Fig. 13 Lab View GUI

VI. CONCLUSION

In this paper, design of solid-state battery/supercapacitor emulator based on dc-dc converter was described. The emulator is capable of imitating charging behavior of any storage device based on a predefined behavior set by the user. The device is operated by a two-level control structure: high-level emulating controller and low-level input voltage controller. Simulation and experimental results were shown to demonstrate the emulator operation under several conditions.

REFERENCES

- [1] A. Burke, "Batteries and ultracapacitors for electric, hybrid and fuel cell vehicles," *Proc. IEEE*, vol. 95, no. 4, pp. 806-820, Apr. 2007.
- [2] A. Burke, "Ultracapacitor technologies and application in hybrid and electric vehicles," *Int. J. Energy Res.*, vol. 34, pp. 133-151, 2009.
- [3] J. M. Blanes, R. Gutierrez, A. Garrigos, J. L. Lizan and J. M. Guadrado, "Electric vehicle battery life extension using ultracapacitors and an FPGA controlled interleaved buck-boost converter," *IEEE Trans. Power Electron.*, vol. 28, no. 12, pp. 5940 – 5948, Dec. 2013.
- [4] O. Ladin, M. Moshirvaziri and O. Trescases, "Predictive algorithm for optimizing power flow in hybrid ultracapacitor/battery storage systems for light electric vehicles," *IEEE Trans. Power Electron.*, vol. 20, no. 8, pp. 3882 – 1895, Aug. 2013.
- [5] J. Cao and A. Emadi, "A new battery/ultracapacitor hybrid energy storage system for electric, hybrid, and plug-in hybrid electric vehicles," *IEEE Trans. Power Electron.*, vol. 27, no. 1, pp. 122 – 132, Jan. 2012.
- [6] A. Allegre, A. Bouscayrol, P. Delarue, P. Barrade, E. Chattot and S. El Fassi, "Energy storage system with supercapacitor for an innovative subway," *IEEE Trans. Ind. Electron.*, vol. 57, no. 12, pp. 4001-4012, Dec. 2010.
- [7] J. Torreglosa, P. Garcia, L. Fernandez, F. Jurado, "Predictive control for the energy management of a fuel cell-battery-supercapacitor tramway," *IEEE Trans. Ind. Inform.*, To appear.
- [8] D. Iannuzzi and P. Tricoli, "Speed-based state-of-charge tracking control for metro trains with onboard supercapacitors," *IEEE Trans. Power Electron.*, vol. 27, no. 4, pp. 2129 - 2140, Apr. 2012.
- [9] A. Kuperman, U. Levy, J. Goren, A. Zafransky and A. Savernin, "Battery charger for electric vehicle traction battery switch station," *IEEE Trans. Ind. Electron.*, vol. 60, no. 12, pp. 5391 – 5399, Dec. 2013.
- [10] M. Yilmaz and P. Krein, "Review of battery charger topologies, charging power levels and infrastructure for plug-in electric and hybrid vehicles," *IEEE Trans. Power Electron.*, vol. 28, no. 5, pp. 2151-2169, May 2013.