

A Review of Control Schemes for Active Power Filters in Order to Power Quality Improvement

Mohammad Hasan Raouf, Azim Nowbakht, Mohammad Bagher Haddadi, Mohammad Reza Tabatabaei

Abstract—Power quality has become a very important issue recently due to the impact on electricity suppliers, equipment manufacturers and customers. Power quality is described as the variation of voltage, current and frequency in a power system. Voltage magnitude is one of the major factors that determine the quality of power. Indeed, custom power technology, the low-voltage counterpart of the more widely known flexible ac transmission system (FACTS) technology, aimed at high-voltage power transmission applications, has emerged as a credible solution to solve many problems relating to power quality problems. There are various power quality problems such as voltage sags, swells, flickers, interruptions and harmonics etc. Active Power Filter (APF) is one of the custom power devices and can mitigate harmonics, reactive power and unbalanced load currents originating from load side. In this study, an extensive review of APF studies, the advantages and disadvantages of each introduced methods are presented. The study also helps the researchers to choose the optimum control techniques and power circuit configuration for APF applications.

Keywords—Power Quality, Custom Power, Active Filter, Control Approach.

I. INTRODUCTION

POWER electronics based devices/equipments are a major key component of today's modern power processing, at the transmission as well as the distribution level because of the numerous advantages offered by them. These devices, equipments, nonlinear load including saturated transformers, arc furnaces and semiconductor switches and so on, draw non-sinusoidal currents from the utility. Therefore a typical power distribution system has to deal with harmonics and reactive power support [1].

The presence of harmonics and reactive power in the grid is harmful, because it will cause additional power losses and malfunctions of the grid components [2]. Conventionally, passive filters consisting of tuned L-C components have been widely used to suppress harmonics because of their low initial cost and high efficiency. However, passive filters have many disadvantages, such as large size, mistuning, instability and resonance with load and utility impedances [3]. Active Power Filters have become an alternative solution for controlling current harmonics in supply networks at the low to medium voltage distribution level or for reactive power and/or voltage control at high voltage distribution level [4].

Mohammad Hasan Raouf, Mohammad Bagher Haddadi, and Mohammad Reza Tabatabaei are with Department of Electrical Engineering, Beyza Branch, Islamic Azad University, Beyza, Iran (e-mail: Haddadi_Mohammad@yahoo.com).

A. Nowbakht is with Shiraz Electric Power Distribution Company, Iran.

Active power filters such as shunt APFs, series APFs, hybrid APFs, unified power quality conditioner (UPQC) and other combinations have made it possible to mitigate some of the major power quality problems [1].

APF system can be divided into two sections as given in Fig. 1. The control unit and the power circuit and the control unit consist of reference signal generation, gate signal generation, and capacitor voltage balance control and voltage/current measurement. Power circuit of APF is generally comprised of energy storage unit, DC/AC converter, harmonic filter and system protection.

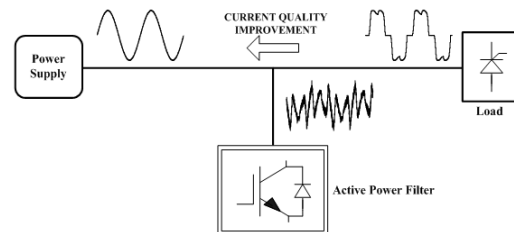
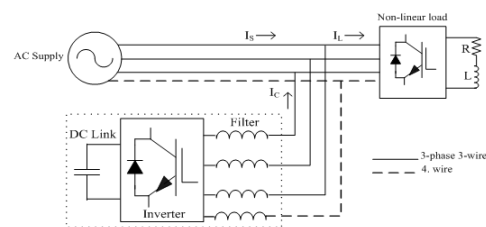

Fig. 1 Fundamental representation of APF

The findings of the comprehensive literature survey summarize the available studies related with the control unit and the power circuit of the APF.

II. POWER CIRCUIT OF APF

APFs are basically categorized into four types, namely, two-wire (single-phase) [5], three-phase three-wire [3], three-phase three-wire with Zig-Zag transformer [6] and three-phase four-wire [7] configurations to meet the requirements of the various types of nonlinear loads on supply systems [8]. Basic topologies of APF are shown in Fig. 2.



(a) 3-phase 3-wire and 3-phase 4-wire topology

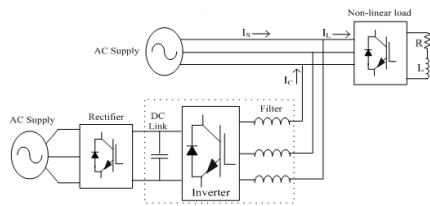

(b) 3-phase 3-wire with rectifier supported topology

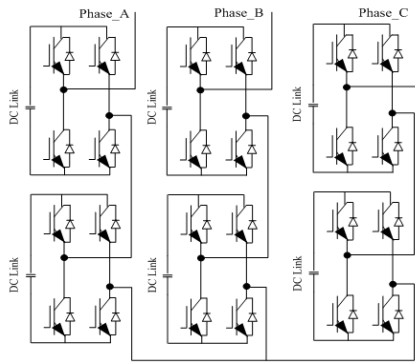

(c) 3-phase 3-wire with multilevel topology

Fig. 2 Various power circuit topologies of APF

APFs are used in low power (<100 KVA), medium power (100 kVA-10 MVA) and high power (>10 MVA) applications [4]. For low power applications, APFs can be applied for single-phase and three-phase systems. For single-phase systems, APFs generally mitigate the current harmonics. For three-phase systems, APFs generally provide acceptable solution for unbalanced load currents and mitigate the current harmonics. For medium power applications, the main aim is to eliminate or reduce the current harmonics. Because of economic considerations, reactive power compensation using active filters at the high voltage distribution level is not generally regarded as viable [4]. For high power applications, the harmonic pollution in high-power ranges is not such a major problem as in lower-power systems. One of the few applications of active filters in high power systems is the installation of parallel combination of several active filters because the control and co-ordination requirements of these filters are complicated. The power circuit of APF generally consists of DC energy storage unit, DC/AC converter and passive filter.

A. DC Energy Storage

The DC capacitor serves two main purposes: (1) It maintains a DC voltage with a small ripple in steady state and (2) It serves as an energy storage element to supply the real power deference between load and source during the transient period [9]. DC link voltage should be higher than maximum peak of the source voltage. DC link voltage can be controlled using proportional-integral (PI) controller [10], proportional-integral-derivative (PID) controller [11] and fuzzy logic [12]. In [3], DC link is fed from separate voltage source to

stabilize DC-side voltage within a certain range. Switched capacitor APF that brings new dimension to APF as it reduces components and ratings (particularly capacitor) while performing at low switching frequency is evaluated in [13]. DC link, instead of a capacitor, is used as a battery pack, which is charged from a photovoltaic array in [14].

B. DC/AC Converter

The converter types of APF can be either Current Source Inverter or Voltage Source Inverter (VSI) bridge structure. VSI structures with insulated gate bipolar transistors (IGBTs) or gate turn-off thyristors (GTO) have become more dominant, since it is lighter, cheaper and expandable to multilevel and multi step versions, to enhance the performance with lower switching frequencies [8]. IGBTs are generally used up to 1 MVA rating, GTO thyristors are generally used higher than 1 MVA rating.

Power circuit configuration of APFs can be parallel active filter [15], series active filter [16] and combination of series and parallel filters [4], [8]. The purpose of parallel active filters is to cancel the load current harmonics fed to the supply. It can also perform the reactive power compensation and balancing of three-phase currents. The series active filter produces a PWM voltage waveform which is added/subtracted to/from the supply voltage to maintain a pure sinusoidal voltage waveform across the load. However, series active filters are less common industrially than their rivals, parallel active filters [8]. Combinations of several types of filter can achieve greater benefits for some applications.

The examined combinations are combination of both parallel and series active filters, combination of series active and parallel passive filters, combination of parallel active and passive filters [17] and active filter in series with parallel passive filters [18]. Seven-level APF configuration is also examined in [19], [20]. Multilevel three-leg center-split VSIs are more preferable in medium and large capacity applications due to lower initial cost and fewer switching devices that need to be controlled [21]. The series-stacked-multilevel-converter topology, which allows standard three-phase inverters to be connected with their DC busses in series, is chosen in [22]. This converter has both regenerated energy generation and active power filtering capabilities.

C. Harmonic Filter

An inductance for output filtering of VSI is used to eliminate the harmonic at different frequencies. The different combinations of L and C filters to attenuate the switching ripple currents are examined in [23]. A rectifier employing phase control with extra low inductance characteristic or load which high-frequency input current, may affect the APF and causing it to malfunction or shutdown. While APF is being applied to this type of load, a reactor (3% ~ 5%) is recommended to install at the input side of the load to reduce the rising rate of load input current [24]. LC passive filter is used in [3] for harmonic elimination and reactive power compensation. LCL-filter presented in [25] gives advantages in costs and dynamic performance since smaller inductors can be used compared to

L-filter in order to achieve the necessary damping of the switching harmonics.

III. CONTROL TECHNIQUES

Active power filters are generally designed to compensate the current harmonics, reactive power, and voltage harmonics and to balance the mains current and voltage. Control strategy is based on the overall system control, extraction of reference signal, capacitor voltage balance control and generation of gating signals as shown in Fig. 3.

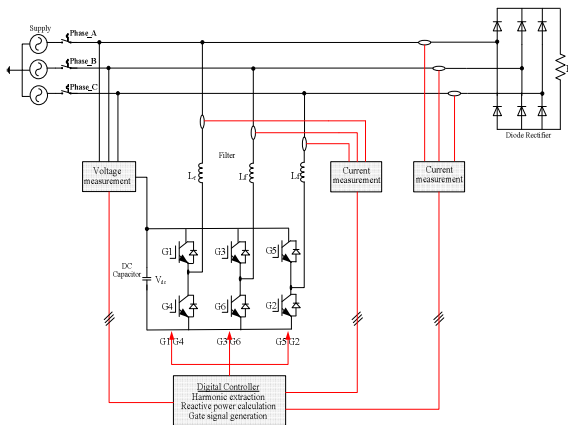

Fig. 3 Control unit of APF with a specified power circuit topology

The general control techniques to overcome these power quality disturbances are open loop control system and closed loop control system. The closed loop controls can be further subdivided into other techniques as constant capacitor voltage technique, constant inductor current technique, optimization techniques and linear voltage control technique [4].

Classification according to current/voltage reference estimation techniques can be made as time domain control and frequency domain control that are processed by the open loop or closed loop control techniques [4]. Control strategy in the frequency domain is based on the Fourier analysis of the distorted voltage or current signals to extract compensating current/voltage reference [8]. Frequency domain approaches are suitable for both single and three-phase systems. The frequency domain algorithms are conventional Fourier and fast Fourier transform (FFT) algorithms [26], sine multiplication technique [4] and modified Fourier series techniques [27].

Control methods of the APF's in the time domain are based on instantaneous derivation of compensating commands in the form of either voltage or current signals from distorted and harmonic polluted voltage or current signals [8]. Time domain approaches are mainly used for three-phase systems. The time domain algorithms are neural network [13], constant active power algorithm, constant (unity) power factor algorithm [15], DQ method [26], instantaneous reactive power algorithm (p-q) [28], fictitious power compensation algorithm [29] and synchronous flux detection algorithm [30]. A component which has a frequency between the two frequencies is called an inter-harmonic. A method for real-time detection and

extraction of inter-harmonic components in a power signal with potentially time-varying characteristics is presented in [31].

The measurements of supply voltage, load current, injected current and capacitor voltage are required for reactive current extraction [28]. However, the measurements of load current, injected current and capacitor voltage is enough for only harmonic current extraction in [32]. In [33], there is no need to measure the load current or power to calculate the reference currents.

The switching signals for the solid state devices of the APF are generated using deadbeat [5], hysteresis [7], PWM [19], multi-resonant controller [34], space vector modulation (SVM) [35], sliding-mode [36] or fuzzy logic based control techniques [37]. The capacitor voltage balance control is performed using PI controller [38], Artificial Neural Network (ANN) based adaptive PI controller [39], fuzzy controller [40] and SVM [41] methods.

IV. CONCLUSIONS

Active Power Filter can mitigate some types of power quality disturbances such as harmonics, reactive power and unbalanced load currents. These disturbances can cause disoperation of highly automated systems and malfunction of sensitive loads connected to point of common coupling (PCC) which increases the economical cost of fault. APF can be very effective solution such a high technology industrial plants or the group of customers having sensitive loads in Custom Power Park or Power Quality Park. This paper has been mainly concentrated on the converter topologies and the control algorithms. A number of APF topologies have been reviewed. With this study, the findings about APF studies in the literature and the application notes of APF in service are presented and thus the trends of APF through the years are clearly observed.

REFERENCES

- [1] V. Khadkikar, A. Chandra, B.N. Singh, "Generalized single-phase p-q theory for active power filtering: simulation and DSP-based experimental investigation", *Power Electronics, IET*, 2: 67-78, 2009.
- [2] A. Luo, Z. Shuai, W. Zhu, "Combined system for harmonic suppression and reactive power compensation", *Industrial Electronics, IEEE Transactions*, 56: 418-428, 2009.
- [3] S. Charles, and G. Bhuvaneswari, "Comparison of three phase shunt active power filter algorithms," *International Journal of Computer and Electrical Engineering*, vol. 2, no. 1, pp. 175-180, Feb. 2010.
- [4] S.P. Litran, P. Salmeron, J.R. Vazquez, and J.L. Flores, "Compensation of voltage unbalance and current harmonics with a series active power filter," *Renewable Energy & Power Quality Journal*, no. 3, Mar. 2005.
- [5] H. Fujita, "A single-phase active filter using an H-bridge PWM converter with a sampling frequency quadruple of the switching frequency", *Power Electronics, IEEE Transactions*, 24: 934-941, 2009.
- [6] H.L. Jou, K.D. Wu, J.C. Wu, W. Chiang, "A three-phase four-wire power filter comprising a three-phase three-wire active power filter and a zig-zag transformer", *Power Electronics, IEEE Transactions*, 23: 252-259, 2008.
- [7] O. Vodyakho, T. Kim, "Shunt active filter based on three-level inverter for three-phase four-wire systems", *Power Electronics, IET*, 2: 216-226, 2009.
- [8] B. Singh, K. Al-Haddad, A. Chandra, "A review of active filters for power quality improvement", *IEEE Tran. Industrial Electronics*, 46: 960-971, 1999.
- [9] S. Rahmani, K. Al-Haddad, and H.Y. Kanaan, "A comparative study of shunt hybrid and shunt active power filters for single-phase applications:

- Simulation and experimental validation,” *Mathematics and Computers in Simulation*, vol. 71, no. 4, pp. 345-359, Jun. 2006.
- [10] T. Mahalekshmi, “Current harmonic compensation and power factor improvement by hybrid shunt active power filter,” *International Journal of Computer Applications* (0975–8887), vol. 4, no. 3, pp. 9-13, Jul. 2010.
- [11] N.A. Rahim, W.P. Hew, S.H. Lim, “Simple control strategy for fuzzy logic controlled active power filter”, 10th Conference on Artificial Intelligence and Applications, National University of Kaohsiung, 2005.
- [12] B. Brahim, B. Chellali, D. Rachid, F. Brahim, “Optimization of shunt active power filter system fuzzy logic controller based on ant colony algorithm”, *Journal of Theoretical and Applied Information Technology*, 14: 117-125, 2010.
- [13] M.A.M. Radzi, N.A. Rahim, “Neural network and bandless hysteresis approach to control switched capacitor active power filter for reduction of harmonics”, *IEEE Transactions on Industrial Electronics*, 56: 1477-1484, 2009.
- [14] P. Flores, J. Dixon, M. Ortuzar, R. Carmi, P. Barriuso, L. Moran, “Static VAR compensator and active power filter with power injection capability using 27-level inverters and photovoltaic cells”, *Industrial Electronics, IEEE Transactions*, 56: 130-138, 2009.
- [15] K.R. Uyyuru, M. Mishra, K.A. Ghosh, “An optimization-based algorithm for shunt active filter under distorted supply voltages”, *Power Electronics, IEEE Transactions*, 24: 1223-1232, 2009.
- [16] O.S. Senturk, A.M. Hava, “High performance harmonic isolation and load voltage regulation of the three-phase series active filter utilizing the waveform reconstruction method”, *IEEE Transactions on Industry Applications*, 45: 2030-2038, 2009.
- [17] A. Luo, Z. Shuai, W. Zhu, Z.J. Shen, C. Tu, “Design and application of a hybrid active power filter with injection circuit”, *Power Electronics, IET*, 3: 54–64, 2010.
- [18] P. Salmeron, S.P. Litran, “Improvement of the electric power quality using series active and shunt passive filters,” *Power Delivery, IEEE Transactions*, 25: 1058–1067, 2010.
- [19] A.M. Massoud, S.J. Finney, B.W. Williams, “Seven-level shunt active power filter”, *Harmonics and Quality of Power, International Conference*, 11: 136-141, 2004.
- [20] P. Xiao, G.K. Venayagamoorthy, K.A. Corzine, “Seven-level shunt active power filter for high-power drive systems”, *Power Electronics, IEEE Transactions*, 24: 6-13, 2009.
- [21] N.Y. Dai, M.C. Wong, N. Fan, Y.D. Han, “A FPGA-based generalized pulse width modulator for three-leg center-split and four-leg voltage source inverters”, *Power Electronics, IEEE Transactions*, 23: 1472-1484, 2008.
- [22] P.H. Henning, H.D. Fuchs, A.D.L. Roux, H.A.T. Mouton, “1.5-MW seven-cell series-stacked converter as an active power filter and regeneration converter for a DC traction substation”, *Power Electronics, IEEE Transactions*, 23: 2230-2236, 2008.
- [23] M. Routimo, H. Tuusa, “LCL type supply filter for active power filter, comparison of an active and a passive method for resonance damping” *IEEE Power Electronics Specialists Conference*, 2939-2945, 2007.
- [24] <http://www.ablerex-ups.com.sg/note.pdf>, (available on-line), 2010.
- [25] O.C.C. Vodyakho Mi, “Three-level inverter-based shunt active power filter in three-phase three-wire and four-wire systems”, *IEEE transactions on power electronics*, 24: 2009.
- [26] S.H. Fathi, M. Pishvaei, G.B. Gharehpetian, “A frequency domain method for instantaneous determination of reference current in shunt active filter”, *TENCON, IEEE Region 10 Conference*, 1-4, 2006.
- [27] Z. Salam, P. C. Tan, A. Jusoh, “Harmonics mitigation using active power filter: A technological review”, *Harmonics Mitigation Using Active Power Filter: A Technological Review, Elekrika Journal of Electrical Engineering*, 8: 17-26, 2006.
- [28] A. Mauricio, A. Hirofumi, H.W. Edson, S. Eumir, F.E. Lucas, “Comparisons between the p-q and p-q-r theories in three-phase four-wire systems”, *IEEE Transactions on Power Electronics*, 24(4): 2009.
- [29] S.A.O. Silva, R. Novochadlo, R.A. Modesto, “Single-phase PLL structure using modified p-q theory for utility connected systems” *IEEE Power Electronics Specialists Conference*, 4706-4711, 2008.
- [30] D. Li, Q. Chen, Z. Jia, C. Zhang, “A high-power active filtering system with fundamental magnetic flux compensation”, *Power Delivery, IEEE Transactions*, 21: 823-830, 2006.
- [31] M. Mojiri, M.G. Karimi, A. Bakhshai, “Processing of harmonics and interharmonics using an adaptive notch filter”, *Power Delivery IEEE Transactions*, 25: 534–542, 2010.
- [32] H. Karimi, M. Karimi-Ghartemani, M.R. Iravani, A.R. Bakhshai, “Adaptive filter for synchronous extraction of harmonics and distortions”, *IEEE transactions on power delivery*, 18(4): 2003.
- [33] H.J. Azevedo, J.M. Ferreira, A.P. Martins, A.S. Carvalho, “An active power filter with direct current control for power quality conditioning”, *Electric Power Components and Systems*, 36: 587-601, 2008.
- [34] M. Pucci, M. Vitale, A. G. Miraoui, “Current harmonic compensation by a single-phase shunt active power filter controlled by adaptive neural filtering”, *Industrial Electronics, IEEE Transactions*, 56: 3128-3143, 2009.
- [35] H. Zhang, A.M. Massoud, S.J. Finney, Williams B.W., Fletcher J.E., “Operation of an active power filter with line voltage SVM under non-ideal conditions”, *Compatibility in Power Electronics*, 1-7, 2007.
- [36] J. Matas, L.G. Vicuna, J. Miret, J.M. Guerrero, M. Castilla, “Feedback linearization of a single-phase active power filter via sliding mode control”, *Power Electronics, IEEE Transactions*, 23: 116-125, 2008.
- [37] Y. Qu, W. Tan, Y. Yang, “A fuzzy adaptive detecting approach of harmonic currents for active power filter”, *Power Electronics and Drive Systems, 7th International Conference*, 1695-1699, 2007.
- [38] M.C. Jiang, “Analysis and design of a novel three-phase active power filter”, *Aerospace and Electronic Systems, IEEE Transactions*, 37: 824-831, (2001).
- [39] A. Bhattacharya, C. Chakraborty, “ANN based harmonic compensation for shunt active power filter with capacitor voltage based predictive technique”, *Industrial and Information Systems, IEEE Third international Conference*, 1-6, 2008.
- [40] P. Kumar, A. Mahajan, “Soft computing techniques for the control of an active power filter”, *IEEE Transactions on Power Delivery*, 24: 452-461, 2009.
- [41] H. Zhang, J.S. Finney, A. Massoud, B.W. Williams, “An SVM algorithm to balance the capacitor voltages of the three-level NPC active power filter”, *Power Electronics, IEEE Transactions*, 23: 2694–2702, 2008.