

Development and Structural Performance Evaluation on Slit Circular Shear Panel Damper

Daniel Y. Abebe, Jaehyoun Choi

Abstract—There are several types of metal-based devices conceived as dampers for the seismic energy absorber whereby damages to the major structural components could be minimized for both new and existing structures. This paper aimed to develop and evaluate structural performance of slit circular shear panel damper for passive seismic energy protection by inelastic deformation. Structural evaluation was done using commercially available nonlinear FE simulation program. The main parameters considered are: diameter-to-thickness (D/t) ratio and slit length-to-width ratio (l/w). Depending on these parameters three different buckling mode and hysteretic behavior was found: yielding prior to buckling without strength degradation, yielding prior to buckling with strength degradation and yielding with buckling and strength degradation which forms pinching at initial displacement. The susceptible location at which the possible crack is initiated is also identified for selected specimens using rupture index.

Keywords—Slit circular shear panel damper, Hysteresis Characteristics, Slip length-to-width ratio, D/t ratio, FE analysis.

I. INTRODUCTION

STEEL dampers which dissipates seismic energy input to the civil engineering structure from an earthquake through inelastic deformation of metal has been studied in the last three decades. The concept and experimental work of metallic energy dissipating device was began by Kelly in 1972 [1] and Shinner in 1975 [2]. As the development of hysteretic dampers proceeded, two types of dampers using different deformation characteristics of the metal have attracted wide attention: the axial yield type as represented by the buckling-restrained brace (BRB) and the shear yield type represented by the shear panel damper (SPD). The development and investigation on both types of dampers, which are a passive energy control system, are proceeding in recent time [3]-[14]. Passive control systems, also known as passive energy dissipation systems, have been considered an effective and inexpensive way to mitigate earthquake risks to structures because these devices do not rely on external power supply as required by the active energy dissipation devices [7].

A circular shear panel hysteresis damper has been developed and its structural performance was also evaluated in SSEEL (steel structure and earthquake engineering laboratory), Chosun University [8], [9]. It is a type of passive energy dissipating device through metallic deformation of circular shear panel.

D. Y. Abebe is with the Chosun University, Graduate School of Architectural Engineering, Gwangju, 501-759, Korea (phone: 82-62-230-7242; fax: 82-62-230-7155; e-mail: danielyshew@yahoo.com).

J. H. Choi is with the Chosun University, School of Architectural Engineering, Gwangju, 501-759, Korea (e-mail: jh_choi@chosun.ac.kr).

During an earthquake, a large amount of energy is imparted to a structure. The traditional design approach relies on the energy dissipation as a consequence of inelastic deformation of particular structural zones. The permanent damage of the post-disaster structure is often so serious that it would be expensive to repair, if at all possible [10]. The concept of passive energy dissipation, however, attempts to reduce such permanent damage to the structure. The use of energy dissipative devices installed within a structure large portion of the input energy supplied by wind and/or earthquake can be dissipated whereby damages to the major structural components could be effectively reduced. The role of a passive energy dissipater is to increase the hysteretic damping in the structure [11]. Using dissipating device in structure is altering its stiffness and damping and hence influences its structural response. Different researchers have been evaluated passive energy dissipating device in various approach including experimental and analytical. A continuous Bouc-Wen's model [12] is also commonly used to model the inelastic behavior of passive energy dissipating device. In this paper, non linear FE simulation was conducted to develop and evaluate slit CSPD considering diameter-to-thickness ratio of circular panel and slit length-to-width ratio parameter.

II. DEVELOPMENT OF SLIT CIRCULAR SHEAR PANEL DAMPER

The use of damper which can be utilized to dissipate seismic energy in civil engineering structures such as building frame and bridge structure is getting popular in recent design approaches. The proposed slit CSPD relies on the in-plane shear deformation of a thin slit circular diaphragm steel plate welded inside a circular shear ring (CSR). Like shear panel damper and slit CSPD can be placed below a structural beam using a V-brace, and between base plate and bridge girder plate as shown in Figs. 1 (a) and (b) respectively, so that it automatically comes into play in the event of any horizontal excitation. The CSR serves as a boundary element allowing the tensile strips to be formed and the tension field to be developed following the post-buckling of the thin slit circular diaphragm plate. As a result of sufficiently large displacements occurring in the slit circular diaphragm plate, the input energy originating from an earthquake could be dissipated through plastic deformation. The development of slit CSPD is the second phase of CSPD. In other words, it is advanced CSPD because it avoids the stress concentration at the center of circular panel which causes early yielding in the overall devices.

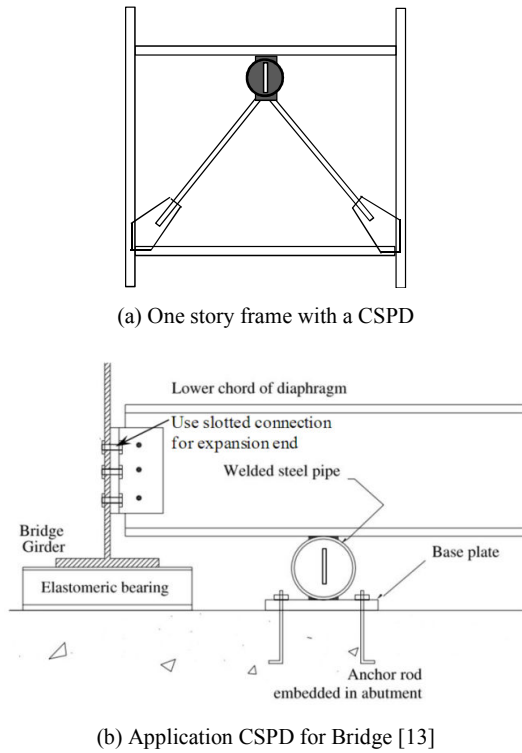

Fig. 1 Samples of circular shear panel damper incorporated into structures

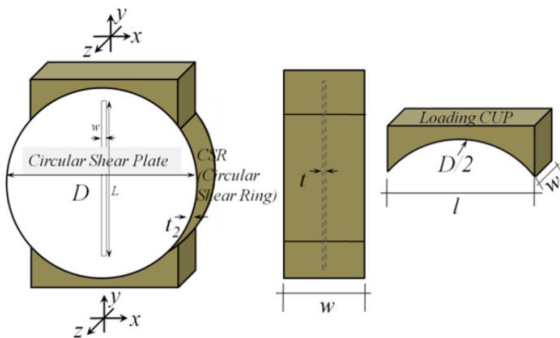

Fig. 2 Specimen Detail

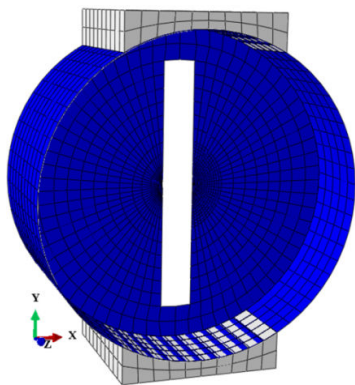

Fig. 3 3D analysis model

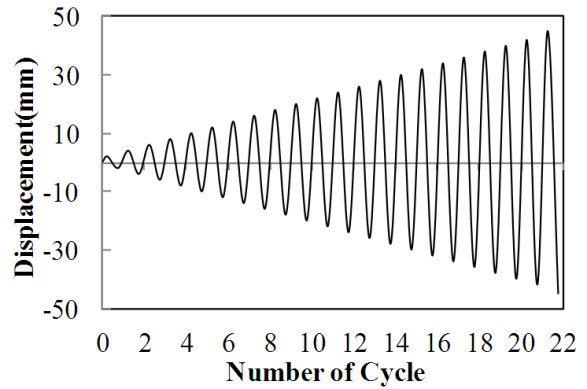

Fig. 4 Loading protocol

III. NONLINEAR FE ANALYSIS

A. Material Modeling

In order to evaluate the structural performance CSPD was discretized using a three dimensional finite element analysis model called Abaqus package to evaluate the structural performance of CSP damper. Material nonlinearity was included in the finite element model by specifying a stress-strain curve in terms of the true stress and plastic strain. The engineering stresses and strains obtained from the coupon tests were converted into true stresses and strains for this purpose. Both solid and shell element model have been tried in order to choose the suitable element to simulate the hysteresis behavior. A 3-D shell element S4R quadrilateral elements through mesh generation by Python script is found to be more efficient in modeling CSP damper with linear interpolation and reduced integration are used, as shown in Fig. 3. The structural steel components are modeled as an elastic-plastic material. With elastic and plastic options, the yield and ultimate tensile strength obtained firstly from the results of the coupon tests and then converted into the true stress and plastic strain with appropriate input format for Abaqus. In the plastic range the important behavior of structural steel to be considered is strain hardening. Thus, mixed hardening (i.e. combined isotropic and kinematic hardening) model was used. Different mesh sizes have been examined as well to determine a reasonable mesh that provides both accurate results with less computational time. The exam results show that, if the mesh is too coarse, a convergence problem will be caused as the contact element was used between the circular hollow section and the endplate surface. However, if the mesh is too fine, the computational time is excessive.

The analysis specimen is composed of circular plate, circular shear ring and longing cup. It is coded like D300t8: means diameter 300mm and thickness 8mm.

B. Load Protocol

All the translational and rotational displacement components are fixed at lower end plate. A cyclic load was given at upper end plate in Y-direction fixing all the translation and rotation in other direction. The boundary condition and method of loading adopted in the finite element analysis followed closely those

used in the tests. A constant strain loading is implemented in which the load is applied by controlling the displacement with the displacement protocol shown in Fig. 4. The thickness of CHS and length is 3.2mm and 50mm respectively. A curved solid rigid body is introduced both ends which have a secant length of equal to the radius of circular plate.

IV. RESULTS AND DISCUSSIONS

The von Mises stress contour and deformed shape of analysis specimen having circular shear plate, diameter=300mm and thickness=8.0mm ($D/t=37.5$), slit length=200mm, slit width=10mm ($L/w=20$) circular shear ring of $D=300$ mm, width=50mm and $t=3.2$ mm is shown in Fig. 5 for detail presentation.

The hysteresis loop (shear force-inelastic rotation relationship) of the same specimen is presented in Fig. 6. From the hysteresis loops, the cumulative energy dissipated by the developed device is calculated and presented in Fig. 7. Cumulative energy is calculated using equation:

$$E_T = \sum_{i=1}^n E_i \quad (1)$$

where: E_T : is the total energy, E_i : energy at cycle i , n : is number of cycle.

The relationship between shear force and cumulative plastic displacement (CPD) is plotted in Fig. 8. As shown in the figure, the analysis model of $D/t=37.5$, $L/w=20$ has a capacity of cumulative plastic deformation approximately about 942mm.

The indexes mainly used to evaluate the crack susceptibility are stress triaxiality, PEEQ Index and rupture index. These indexes are described here below. Different possible locations were considered and the indexes are calculated.

Stress Triaxiality ratio (τ): given as the ratio of hydrostatic or mean stress to the equivalent von Mises stress, mathematically

$$\tau = \frac{1/3(\sigma_1 + \sigma_2 + \sigma_3)}{\sqrt{0.5(\sigma_1 - \sigma_2)^2 + (\sigma_2 - \sigma_3)^2 + (\sigma_3 - \sigma_1)^2}} \quad (2)$$

PEEQ Index: The failure is predicted by the PEEQ index defined by the triaxiality of the stress field and the accumulated plastic strain in tension and compression [15]-[17]. The objective function is the dissipated energy before failure of the damper. The ductility capacity of the damper is defined using failure index as follows. The variables, which are functions of pseudo-time, such as stresses and strains are evaluated at integrated maximum possible point. Let $\epsilon_p(t)$ denote the equivalent plastic strain defined as:

$$\epsilon_p(t) = \int_0^t \sqrt{\dot{\epsilon}_{ij}^p(\tau) \dot{\epsilon}_{ij}^p(\tau)} d\tau \quad (3)$$

where $\epsilon_{ij}^p(t)$ is the plastic strain tensor, () is the derivative with respect to time, and the summation convention is used. The equivalent plastic strain represents amount of plastic deformation in material level, and is evaluated at each

integration point. Many fracture criteria have been presented using $\epsilon_p(t)$. We use an extended version of the SMCS criterion that was developed for simulating ductile fracture of metals due to void growth.

Then PEEQ index is given by the ratio of the plastic equivalent strain to the yield strain.

$$PEEQ\ Index = \frac{\epsilon_p^p}{\epsilon_y} \quad (4)$$

Rupture Index: defined to evaluate effect from stress triaxiality and local ductility as discussed in [18]

$$RuptureIndex(RI) = \frac{PEEQ}{exp(-1.5\tau)} \quad (5)$$

From different measurement locations the maximum index is found at indicated point of measurement location shown in Fig. 5: i.e. the crack is initiated at the indicated point.

The diameter-to-thickness ratio(D/t) and slit length-to-width ratio (w/L) are the main parameters considered during evaluation of slit CSPD. In addition, the effect of circular shear ring (CSR) is also evaluated in this study.

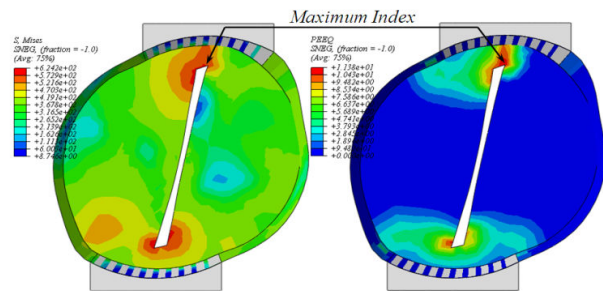

Fig. 5 Deformed shape and PEEQ and von Mises stress distribution for $D/t=37.5$

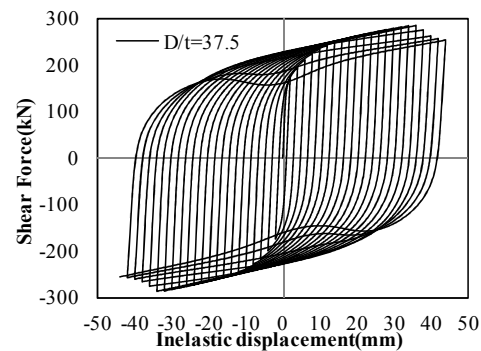

Fig. 6 Shear force-Inelastic rotation relationship

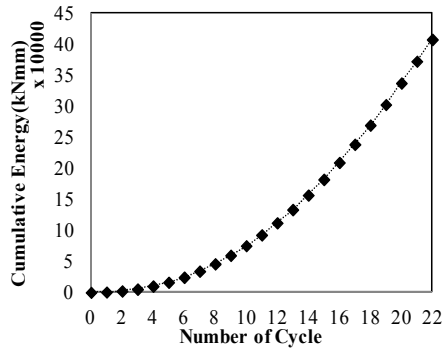

Fig. 7 Cumulative energy and number of cycle relationship for $D/t=37.5$

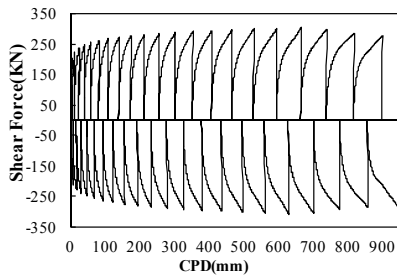

Fig. 8 Shear force and cumulative plastic displacement relationship

A. Effect of Diameter-to-Thickness Ratio (D/t)

The effect of diameter-to-thickness ratio considered in two ways, as stated above, is presented. However, the effect of d/t is sensitive when varying the thickness of circular plate keeping diameter constant. The deformation mode and von Mises stress distribution is shown in Fig. 9 for specimen $D/t=25, 35$ and 40 respectively.

The hysteresis loop of shear force versus shear deformation obtained for different D/t ratio which varies thickness of circular plate is shown in Fig. 10. Three different behaviors are obtained as shown in the Fig. 10: part I is specimen which are yielding prior to buckling without strength degradation Fig. 10 (a). Part II shown in Fig. 10 (b) is yielding prior to buckling with strength degradation and Fig. 10 (c) which is part III show the yielding with buckling and strength degradation which forms pinching at initial displacement. As the thickness decrease the pinching effect become severe. From a total of 16 analysis specimen modeled in this paper for different D/t ratio (for variable thickness) it is found that for specimen having $D/t > 36.36$ were considered as compact specimen in which yielding prior to buckling without strength degradation. $34.20 \leq D/t \leq 36.36$ was yielding prior to buckling with strength degradation. $D/t < 34.20$ yielding with buckling and strength degradation which forms pinching at initial displacement.

B. Effect of Slit Length-to-Width Ratio (L/w)

The effect slit length-to-width ratio is mainly on the shear resisting capacity and cumulative plastic displacement. The main purpose of making slit is to avoid stress concentration at the center of circular plate. The cumulative plastic displacement of slit CSPD is greater than the normal CSPD,

which makes slit CSPD a better seismic energy absorber.

The summary of the effect of diameter-to-thickness ratio and slit length-to-width ratio is presented in Fig. 11.

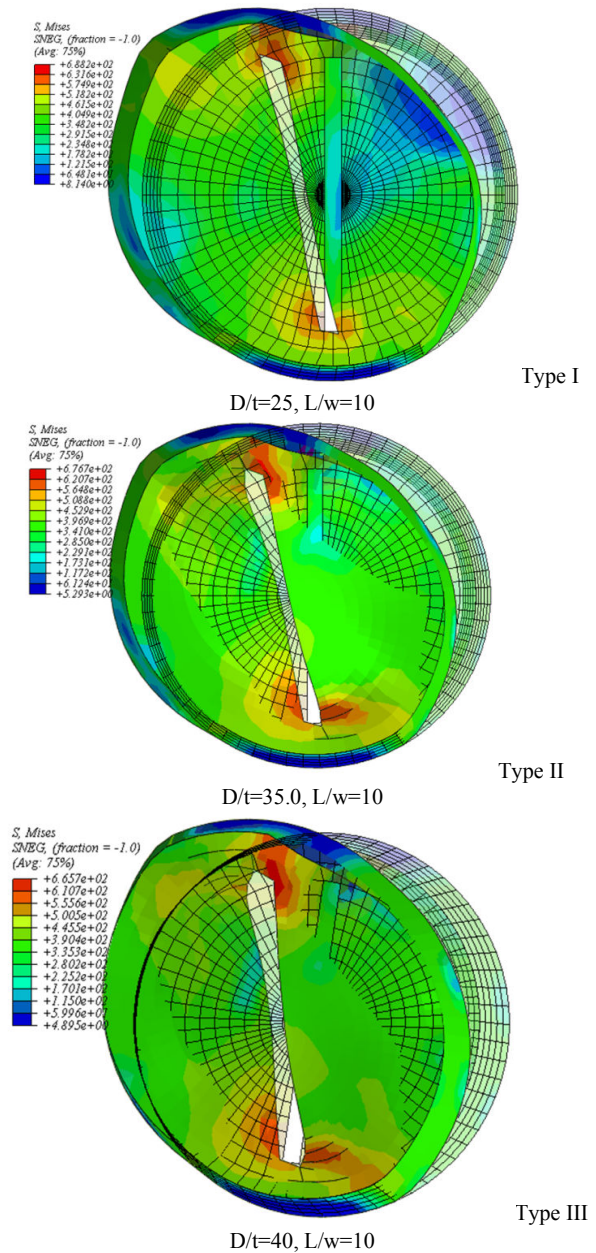

Fig. 9 Deformation mode and von Mises stress distribution

C. Effect of Circular Shear Ring (CSR)

The von Mises stress contour and deformed shape of analysis specimen CHS without circular plate of diameter=100mm and thickness=3.5mm is presented in Fig. 12. The energy absorption capacity and shear capacity of circular hollow section without a thin circular diaphragm is presented in Fig. 13 with variable diameter. The effect of circular shear ring on cumulative energy absorption, initial stiffness and shear

capacity is 7.23%, 4.42% and 8.81% respectively.

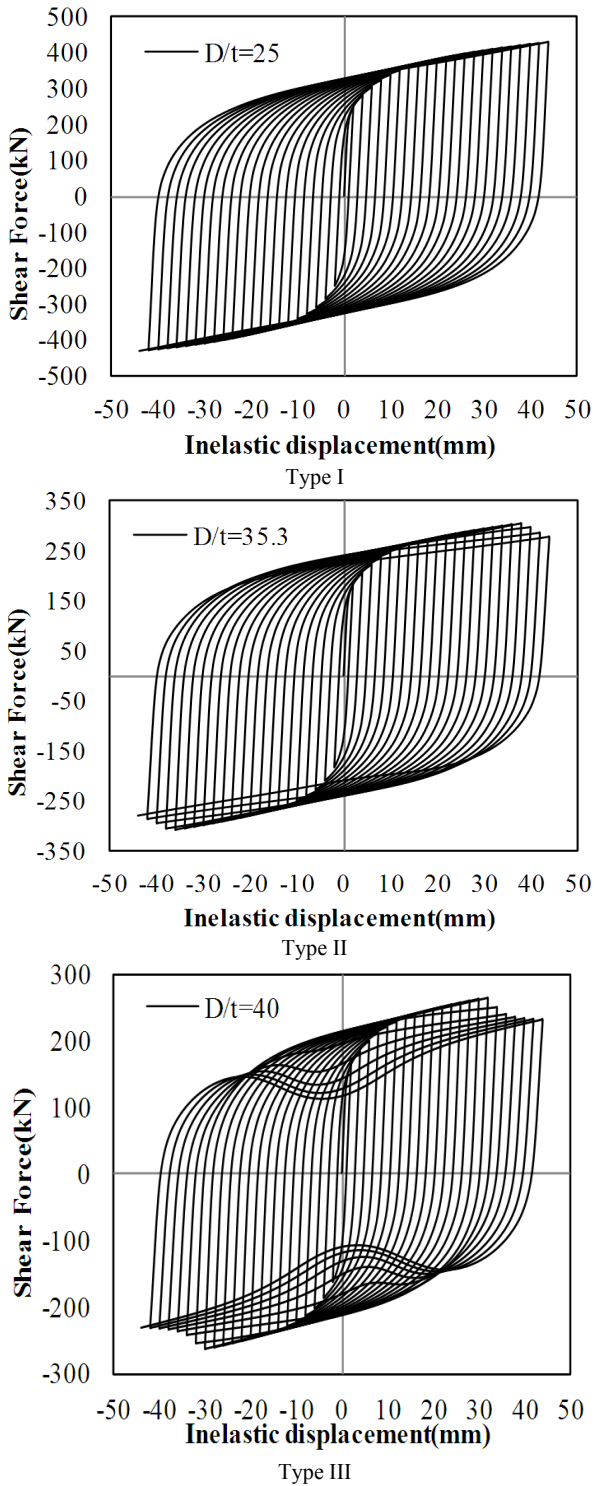

Fig. 10 Effect of D/t ratio on hysteretic behavior of slit CSP damper for L/w=10

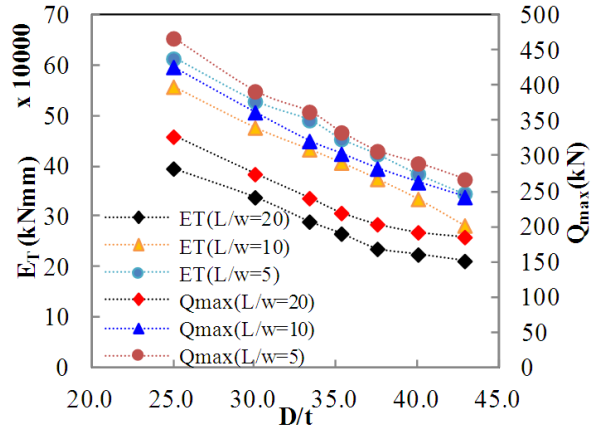

Fig. 11 Effect of diameter-to-thickness ratio and slit length-to-width ratio on maximum shear force and cumulative energy

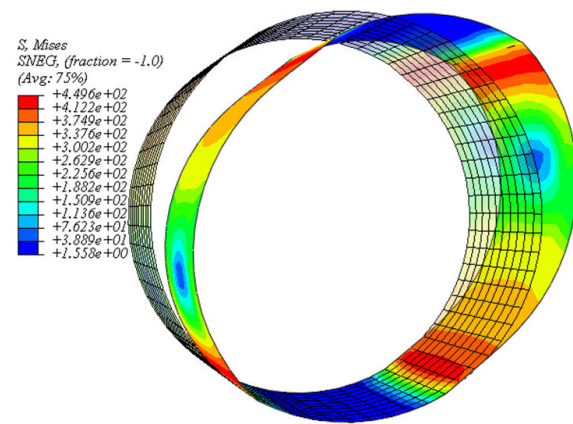

Fig. 12 Deformed shape and von Mises stress distribution on CSR

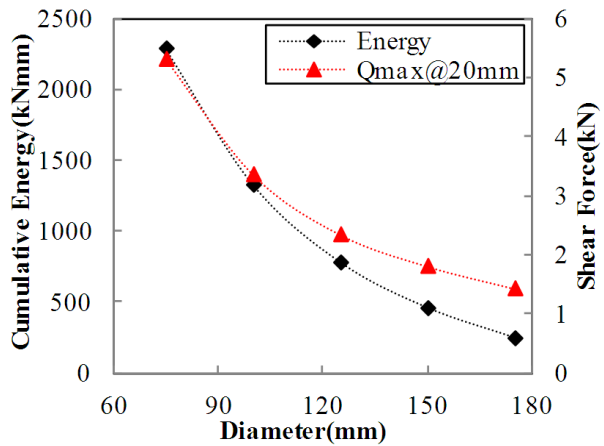

Fig. 13 Cumulative energy and shear capacity of CSR

V. CONCLUSION

This study evaluates the structural performance of slit circular shear panel damper. Different parameters have been considered and D/t ratio has significant effect on the hysteretic behavior, maximum shear resisting capacity and hence

cumulative energy. When the D/t decreases the shear resisting capacity increases and the hysteretic behavior approaches to stable. The effect of slit length-to width (L/w) ratio is more noticed in cumulative plastic displacement (CPD). As the L/t ratio increases the CPD capacity of the damper increases because the early yielding portion of the damper is removed. From the hysteretic behavior is identified; slits CSP damper with stable hysteresis behavior or specimen that deform without strength degradation has most likely to be used as passive energy dissipating device in civil engineering structures.

Generally, the structural behavior of slit CSPD is evaluated using non-linear FE simulation and this study has a significant contribution in field of civil engineering structure.

ACKNOWLEDGMENT

This work was financially supported by Basic Science Research Program through the National Research Foundation of Korea (NRF) funded by the Ministry of Education, Science and Technology (No.2012-0008837).

REFERENCES

- [1] Kelly J. M., Skinner, R. I., and Heine, A. J. 1972 "Mechanisms of energy absorption in special devices for use in earthquake resistant structures," *Bulletin of the New Zealand National Society for Earthquake Engineering* 5, 63–88.
- [2] Skinner R. I., Kelly J. M., and Heine A. J., 1975 "Hysteresis dampers for earthquake-resistant structures," *Earthquake Engineering and Structural Dynamics* 3, 287–296.
- [3] Soong TT, Dargush GF. Passive energy dissipation systems in structural engineering. *John Wiley & Sons*; 1997.
- [4] Soong TT, Spencer Jr BF. Supplemental energy dissipation: State-of-the-art and state-of-the-practice. *Eng Struct* 2002;24:243–59.
- [5] Whittaker AS, Bertero VV, Thompson CL, Alonso LJ. Seismic testing of steel plate energy dissipation devices. *Earthq Spectra* 1991;7(4):563–604
- [6] Bergman DM, Goel SC. Evaluation of cyclic testing of steel plate devices for added damping and stiffness. *Report no. UMCE87-10. Ann Arbor (MI, USA): The University of Michigan*; 1987.
- [7] Tsai K, Chen H, Hong C, Su Y. Design of steel triangular plate energy absorbers for seismic-resistant construction. *Earthquake Spectra* 1993;9(3):505–28.
- [8] Daniel Y. Abebe, Jae Hyouk Choi, Analytical Study on Hysteretic Characteristics of Circular Shear Panel Damper. *Proceeding of International Conference on Advances in Civil, Structural and Mechanical Engineering - CSM*, 01-02 June, 2014, London, UK.
- [9] Daniel Y. Abebe, Jae Hyouk Choi, Analytical Study on Hysteretic Characteristics of Circular Shear Panel Damper. Accepted waiting publication on International Conference on Civil, Structural and Earthquake Engineering, - June 16-17, 2014 Toronto, Canada.
- [10] Ricky W.K. Chana, Faris Albermani, Martin S. Williams, 209. Evaluation of yielding shear panel device for passive energy dissipation. *Journal of Constructional Steel Research* 65, 260–268
- [11] Ian D. Aiken, Douglas K. Nims, Andrew S. Whittaker, and James M. Kelly. Testing of Passive Energy Dissipation Systems. *Earthquake Spectra, Vol. 9, no. 3, Earthquake Engineering Research Institute California, August* (1993).
- [12] Wen YK. Method for random vibration of hysteretic systems. *J Engr Mech* 1976;102:249–63.
- [13] Shervin Malekia, Saman Bagheri 2010. Pipe damper, Part II: Application to bridges. *Journal of Constructional Steel Research* 66, 1096-1106
- [14] S. B. Beheshti-Aval, H. Mahbanouei and F. Zareian 2013. A Hybrid Friction-yielding Damper to Equip Concentrically Braced Steel Frames. *International Journal of Steel Structures, Vol 13, No 4, 577-587.*
- [15] C. S. Oh, N. H. Kim, Y. J. Kim, J. H. Baek, Y. P. Kim, W. S. Kim, 2011, 'A finite element ductile failure simulation method using stress-modified fracture strain model' *Engineering Fracture Mechanics* 78 (2011) 124–137
- [16] Chi WM, Kanvinde AM, Deierlein GG. Prediction of ductile fracture in steel connections using SMCS criterion. *J Struct Eng* 2006;132(2):171–81.
- [17] Kanvinde AM, Deierlein G. Micromechanical simulation of earthquake induced fracture in steel structures. Tech. Rep. TR145, Blume Center, Stanford Univ; 2004.
- [18] Amira A. Hedayat, Murude Celikag. Enhancement of Panel zone (PZ) contribution to the ductility of post-Northridge welded connections. *WSEAS TRANSACTIONS on Applied and Theoretical Mechanics* 5(3) 165-174.

D. Y. Abebe received his B.Sc. degree in civil engineering from BahirDar University, Ethiopia, in 2008 and M.Eng. degrees in Architectural Engineering from Chosun University, Korea, on February 22, 2013. Currently he is pursuing his Ph.D. in Chosun University, Architectural Engineering Department. His research interest includes behavior and design of steel seismic-resisting systems and mechanical behavior of steel structures.

J.H Choi is associate professor of Chosun University. He received his B.E. and M.S. from Kyung-pook National University, Korea. He received Dr. of Engineering from Tokyo University, Japan, in 2003. He is currently engaged on a large government funded research project on the development of Smart Green Construction Technology as well as being involved in ongoing development of the steel seismic-resisting system of buildings.