

# Active Power Flow Control Using A TCSC Based Backstepping Controller in Multimachine Power System

Naimi Abdelhamid, Othmane Abdelkhalek

**Abstract**—With the current rise in the demand of electrical energy, present-day power systems which are large and complex, will continue to grow in both size and complexity. Flexible AC Transmission System (FACTS) controllers provide new facilities, both in steady state power flow control and dynamic stability control. Thyristor Controlled Series Capacitor (TCSC) is one of FACTS equipment, which is used for power flow control of active power in electric power system and for increase of capacities of transmission lines. In this paper, a Backstepping Power Flow Controller (BPFC) for TCSC in multimachine power system is developed and tested. The simulation results show that the TCSC proposed controller is capable of controlling the transmitted active power and improving the transient stability when compared with conventional PI Power Flow Controller (PIPFC).

**Keywords**—FACTS, Thyristor Controlled Series Capacitor (TCSC), Backstepping, BPFC, PIPFC.

## I. INTRODUCTION

Now a day's power system is undergoing changes and becoming more complex from operation, control and stability maintenance standpoints when they meet ever-increasing load demand [1]. In recent years, great demand has been imposed, and it is difficult to construct new transmission lines due to the financial and environmental issues. In this respect, FACTS technology has been proposed to provide the actual capacity without the requirement of new transmission lines or reconfiguration [2].

TCSC as a significant member of FACTS family has been applied to solve diverse problems, such as scheduling fast power flow, limiting short-circuit currents, regulating continuous reactance, mitigating Sub Synchronous Resonance (SSR), damping the power oscillation, enhancing transient stability, etc.[1]-[3].

Backstepping is a good technology which is based on nonlinear theory that combines the Lyapunov function with feedback control [4]. Because of nonlinear characteristics of the TCSC with power system, backstepping technique can be used for control of power flow. A proposed controller based on the backstepping method is designed to control the power flow in this paper.

In the present work, the role of TCSC on active power flow control is discussed for multimachine power system.

Naimi Abdelhamid and Othmane Abdelkhalek are with the Department of Electrical Engineering, University of Bechar, BP 417, 08000 Algeria (e-mail: naimi\_univ@live.fr, othmane\_elec@yahoo.fr).

Backstepping power flow controller (BPFC) for TCSC is proposed and tested. It is compared with PI power flow controller (PIPFC) to improve its performance to damp the power system oscillations under three-phase short circuit fault.

## II. POWER SYSTEM MODELING

The system studied in this paper is the popular Western System Coordinating Council (WSCC) 3-Machine 9-Bus power system single line diagram shown in Fig. 1.

The differential-algebraic equations for the  $m$  machine,  $n$  bus system with IEEE Type-I exciters are [5]:

$$T'_{doi} \frac{dE'_{qi}}{dt} = -E'_{qi} - (X_{di} - X'_{di})I_{di} + E_{fdi} \quad i = 1, \dots, m \quad (1)$$

$$T'_{qoi} \frac{dE'_{di}}{dt} = -E'_{di} + (X_{qi} - X'_{qi})I_{qi} \quad i = 1, \dots, m \quad (2)$$

$$\frac{d\delta_i}{dt} = w_i - w_s \quad i = 1, \dots, m \quad (3)$$

$$\frac{2H_i}{w_s} \frac{dw_i}{dt} = T_{Mi} - E'_{di}I_{di} - E'_{qi}I_{qi} - (X'_{qi} - X'_{di})I_{di}I_{qi} - D_i(w_i - w_s) \quad i = 1, \dots, m \quad (4)$$

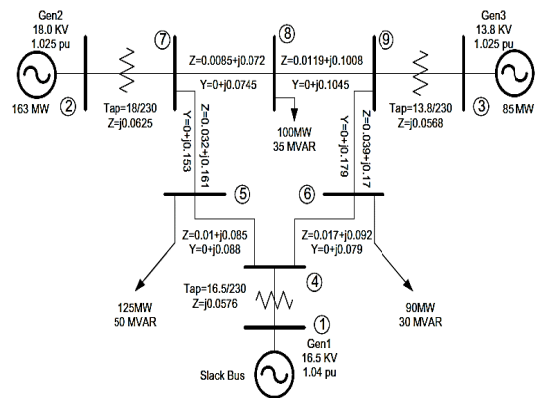

Fig. 1 WSCC 3-Machine 9-Bus power system single line diagram

### A. Modeling the TCSC Dynamics

The main circuit of a TCSC is shown in Fig. 2. It consists of three components: capacitor banks  $C$ , bypass inductor  $L$  and bidirectional thyristors  $T_1$  and  $T_2$ . In Fig. 2,  $i_C$  and  $i_L$  are the instantaneous values of the currents in the capacitor banks and inductor, respectively;  $i_S$  the instantaneous current of the controlled transmission line;  $v$  is the instantaneous voltage

across the TCSC. Control of the TCSC is achieved by the firing angle signal  $\alpha$ , which changes the fundamental frequency reactance of the compensator. There exists a steady-state relationship between the firing angle  $\alpha$  and the reactance  $X_{TCSC}(\alpha)$ . This relationship can be described as following [6]:

$$X_{TCSC}(\alpha) = \beta_1(X_C + \beta_2) - \beta_4\beta_5 - X_C \quad (5)$$

where

$$\beta_1 = \frac{2(\pi - \alpha) + \sin 2(\pi - \alpha)}{\pi} \quad (6)$$

$$\beta_2 = \frac{X_C X_L}{X_C - X_L} \quad (7)$$

$$\beta_3 = \sqrt{\frac{X_C}{X_L}} \quad (8)$$

$$\beta_4 = \beta_3 \tan[\beta_3(\pi - \alpha)] - \tan(\pi - \alpha) \quad (9)$$

$$\beta_5 = \frac{4\beta_3^2 \cos^2(\pi - \alpha)}{\pi X_L} \quad (10)$$

$X_C$  = Nominal reactance of the fixed capacitor  $C$

$X_L$  = Inductive reactance of inductor  $L$  connected in parallel with  $C$

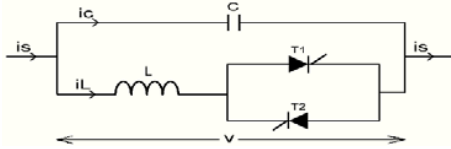

Fig. 2 Configuration of a TCSC

### B. Modes of Operation

TCSC modules have three basic modes of operation [7]:

- Thyristor blocked (no gating and zero thyristor conduction).
- Thyristor bypassed (continuous gating and full thyristor conduction).
- Vernier mode with phase control of gate signals.

In case of blocked operating mode, the TCSC net impedance is just capacitive reactance.

In case of bypass mode, as the thyristors are fully conducting, most of the line current flows through thyristors and hence TCSC has small net inductive reactance.

In vernier control, thyristors are conducted in such a manner that a controlled amount of inductive current can circulate through the capacitor, thereby increasing effective capacitive/inductive reactance of the module.

### III. POWER FLOW CONTROLLER FOR TCSC (PFC)

The TCSC power flow controller can operate in different modes such as constant impedance mode, constant power control mode.

When TCSC operates in the constant power control mode as shown in Fig. 3, the power flow controller (PFC) attempts to minimize the power error ( $\Delta P$ ) which is the difference of

reference power ( $P_{ref}$ ) signal and measured power flowing through line ( $P_{meas}$ ) and gives the reactance ( $X_0$ ).

To adapt this reactance ( $X_0$ ) to the appropriate reactance ( $X_{tcsc}$ ), a transformation block ( $X$  to  $\text{Alpha}$ ) refer to (5) is required then the recalculation of  $X_{tcsc}$  to insert into transmission line.

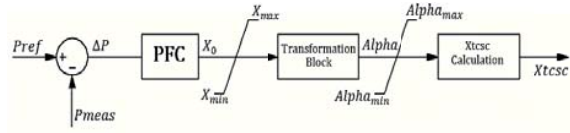

Fig. 3 Power Flow Controller (PFC) diagram for TCSC

#### A. PI Power Flow Controller (PI/PFC)

Here, a conventional proportional integral (PI) controller is designed to determine the TCSC reactance to control the transmitted power. The input signal is the error to minimize ( $\Delta P$ ) as shown in Fig. 4.

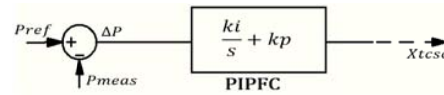

Fig. 4 Proportional Integral Power Flow Controller (PI/PFC) diagram for TCSC

#### B. Backstepping Power Flow Controller (BPFC)

Backstepping method provides an efficient tool for controller design through constructing step by step the Lyapunov functions which can guarantee the asymptotic stability of the overall closed-loop system [8]. With backstepping, the origin nonlinear system doesn't need to be linearized and the closed-loop error system is guaranteed to be asymptotically stable.

Here, a proposed controller based on the backstepping technique is designed to control the power flow. For this purpose, the power error is determined by:

$$\Delta P = e_p = P_{ref} - P_{meas} \quad (11)$$

The derivative of (11) gives

$$\dot{e}_p = \dot{P}_{ref} - \dot{P}_{meas} \quad (12)$$

with

$$P_{meas} = 3 V_{meas} I_{meas} \cos \varphi \quad (13)$$

where

$$I_{meas} = \frac{V_{tcsc}}{X_{tcsc}} \quad (14)$$

The derivative of (13) gives

$$\dot{P}_{meas} = 3 V_{meas} \cos \varphi \left( \frac{V_{tcsc}}{X_{tcsc}} \right) \quad (15)$$

$$= 3 V_{meas} \cos \varphi \left( \frac{V_{tcsc} X_{tcsc} - X_{tcsc} V_{tcsc}}{V_{tcsc}^2} \right) \quad (16)$$

Then we can obtain

$$\dot{e}_p = Pref - 3 Vmeas \cos\phi \left( \frac{Vt\dot{c}sc Xtcsc - Xtcsc Vt\dot{c}sc}{Vt\dot{c}sc^2} \right) \quad (17)$$

Then the Lyapunov function is defined as

$$V_p = \frac{1}{2} e_p^2 \quad (18)$$

Then

$$\dot{V}_p = e_p \dot{e}_p \quad (19)$$

We choose

$$\dot{e}_p = -K_b e_p \quad (20)$$

This implies that

$$\dot{V}_p = -K_b e_p^2 \leq 0 \quad (21)$$

where  $K_b$  is a given positive constant

We can rewrite (17)

$$\dot{e}_p = Pref - 3 Vmeas \cos\phi \left( \frac{Vt\dot{c}sc Xtcsc - Xtcsc Vt\dot{c}sc}{Vt\dot{c}sc^2} \right) \quad (22)$$

$$= -K_b e_p \quad (23)$$

with  $Pref = 0$ ,  $Vt\dot{c}sc = 0$  we obtain

$$Xt\dot{c}sc = \frac{-K_b e_p Vt\dot{c}sc}{3 Vmeas \cos\phi} \quad (24)$$

After integration of  $Xt\dot{c}sc$ , we obtain the output reactance of the proposed controller.

#### IV. SIMULATION RESULTS

The power system shown in Fig. 1 is studied through the computer simulation using the MATLAB/SIMULINK in MATLAB environment.

The TCSC is placed in transmission line 7-5. Fig. 5 shows variation of TCSC reactance ( $Xt\dot{c}sc$ ) against of the firing angle  $\alpha$  refer to (5).

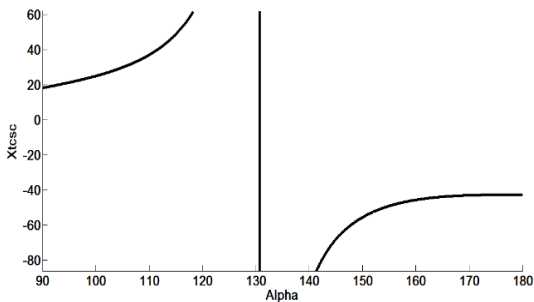

Fig. 5  $X_{TCSC}$  vs.  $\alpha$  Characteristic of TCSC

In vernier control, one is the  $141.4^\circ \leq \alpha \leq 180^\circ$  where  $X_{TCSC}(\alpha)$  is capacitive, and the other is the  $90^\circ \leq \alpha \leq 118.3^\circ$  where  $X_{TCSC}(\alpha)$  is inductive.

To assess the effectiveness of the proposed BPFC, we control the power flow through line 7-5 with a step variation of  $Pref = [110 \ 100 \ 110]$  (MW) at time  $t = [0 \ 10 \ 25]$  in capacitive mode (Fig. 6) and  $Pref = [75 \ 80 \ 75]$  (MW) at time  $t = [0 \ 10 \ 25]$  in inductive mode (Fig. 7).

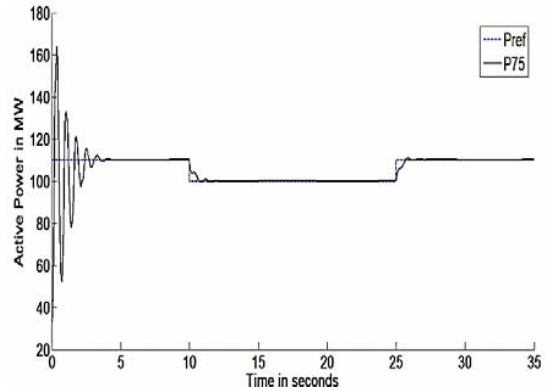

Fig. 6 (a) Power Flow in line 7-5

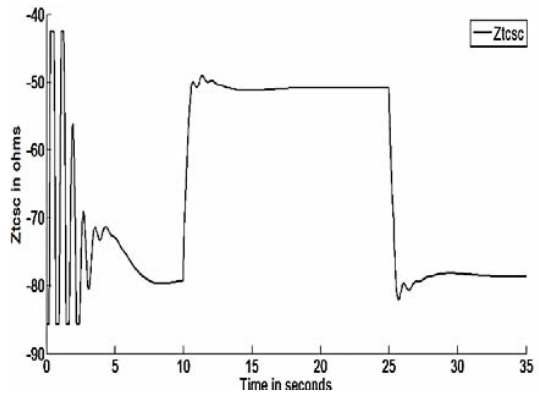

Fig. 6 (b)  $X_{TCSC}$  of TCSC

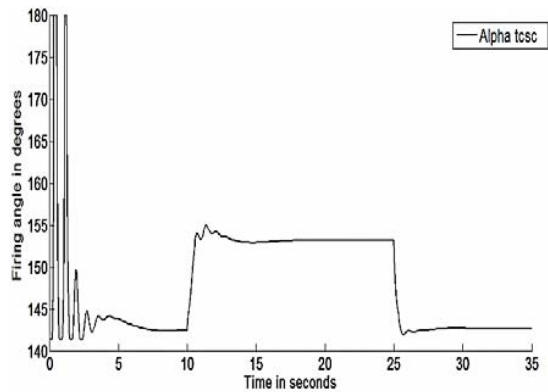

Fig. 6 (c) TCSC Firing Angle

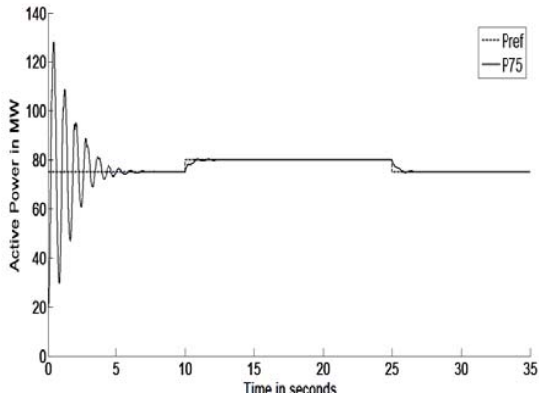

Fig. 7 (a) Power Flow in line 7-5

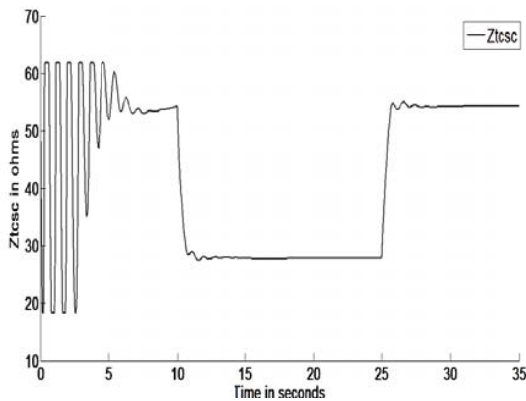

Fig. 7 (b)  $X_{TCSC}$  of TCSC

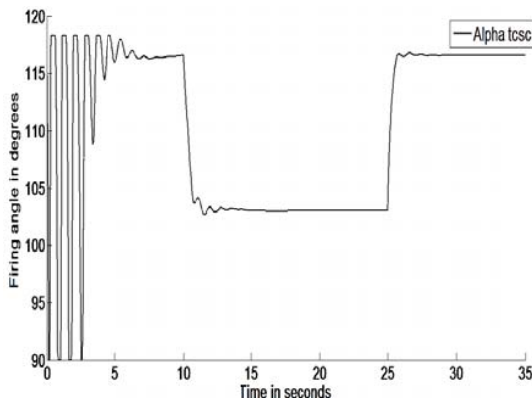

Fig. 7 (c) TCSC Firing Angle

Results show the effectiveness of BPFC to control the transmitted active power. Without the TCSC the power transfer is around 86 MW. In capacitive mode, the range for impedance values is approximately 42-86 ohm, the power transfer increases as the firing angle is reduced.

In the inductive operating mode, the range of impedances is 18-62 ohm, the inductive mode reduces power transfer over the line.

For transient stability analysis three-phase short circuit fault at bus 7 at time  $t=13$  sec and cleared at  $t=13.1$  sec is

considered. Fig. 8 shows oscillations in power through the line 7-5 for three-phase short circuit at bus 7 without and with TCSC power flow controller (BPFC, PIPFC).

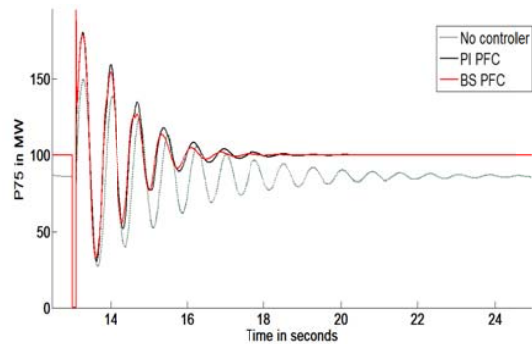

Fig. 8 Oscillations in Power through the line 7-5 for Three-Phase Short Circuit at Bus-7

It is obvious from the Fig. 8 that without TCSC the power oscillations take more time to settling down, the BPFC gives better damping characteristics compared to PIPFC.

#### V. CONCLUSION

In this study, the power system with TCSC is presented. Active power flow controller for TCSC based on backstepping technique (BPFC) has been proposed for improving and controlling the power flows in the network, can help to increase the power flows in heavily loaded lines. Simulation results show the effectiveness of the proposed controller of TCSC in controlling active power through the transmission line, and it more effective than PIPFC in damping power oscillations.

#### APPENDIX

TABLE I  
GENERATORS AND EXCITERS DATA OF 3-MACHINE 9-BUS WSCC POWER SYSTEM

Machine Data	M1	M2	M3
$X_d$ (pu)	0.146	0.8958	1.3125
$X'_d$ (pu)	0.0608	0.1198	0.1813
$X_q$ (pu)	0.0969	0.8645	1.2578
$X'_q$ (pu)	0.0969	0.1969	0.25
$T'_{do}$ (sec)	8.96	6.0	5.89
$T'_{qo}$ (sec)	0.31	0.535	0.6
$H$ (sec)	23.64	6.4	3.01
Exciter Data	Exciter 1	Exciter 2	Exciter 3
$K_A$	20	20	20
$T_A$ (sec)	0.2	0.2	0.2
$K_E$	1.0	1.0	1.0
$T_E$ (sec)	0.314	0.314	0.314
$K_F$	0.063	0.063	0.063
$T_F$ (sec)	0.35	0.35	0.35

TABLE II  
TCSC DATA

Parameters	Capacitive mode	Inductive mode
$X_C$ (ohm)	42.58	42.58
$X_L$ (ohm)	12.78	12.78
$X_{max}$ (ohm)	86	62
$X_{min}$ (ohm)	42	18
$\alpha_{max}$ (degree)	180	118.3
$\alpha_{min}$ (degree)	141.4	90
$k_p$ (PIPFC)	0.8	0.8
$k_i$ (PIPFC)	9	9
$K_b$ (BPFC)	150	400

## REFERENCES

- [1] "Voltage stability of power systems: concepts, analytical Tools, and experience", IEEE Special Publication 90th 03582 PWR, 1990.
- [2] K. R. Padiyar, "FACTS Controllers in Power Transmission and Distribution", Tunbridge Wells, Anshan, 2009.
- [3] X. Tan, N. Zhang, L. Tong, Z. Wang, "Fuzzy control of thyristor controlled series compensator in power system transients", Fuzzy Sets and Syst., Vol. 110, pp. 429-436, 2000.
- [4] Zhu, L; Liu, HM; Cai, ZX; Ni, Y "Nonlinear Backstepping Design of Robust Adaptive Modulation Controller for TCSC", IEEE Power Engineering Society General Meeting, Montreal, Canada, 18-22 June 2006.
- [5] P.W. Sauer, M.A. Pai, "Power System Dynamics and Stability", Pearson Education, New Delhi, 2002.
- [6] D. Chatterjee, A Ghosh, "TCSC control design for transient stability improvement of a multi-machine power system using trajectory sensitivity", Electric Power Systems Research 77 470-483, 2007.
- [7] E.V.Larsen, K.Clark, S.A.Miske, J.Urabanek "Characteristics and Rating Considerations of Thyristor Controlled series Compensation", IEEE Transactions on Power Delivery, Vol. 9, No. 2, pp.992-1000, April 1994.
- [8] Z. Cai, L. Zhu, Z. Lan, D. Gan, Y. Ni, L. Shi, T. Bi "A study on robust adaptive modulation controller for TCSC based on COI signal in interconnected power systems", Electric Power Systems Research, vol. 78, no. 1, pp. 147-157, 2008.