

Improving Ride Comfort of a Bus Using Fuzzy Logic Controlled Suspension

Mujde Turkkan, Nurkan Yagiz

Abstract—In this study an active controller is presented for vibration suppression of a full-bus model. The bus is modeled having seven degrees of freedom. Using the achieved model via Lagrange Equations the system equations of motion are derived. The suspensions of the bus model include air springs with two auxiliary chambers are used. Fuzzy logic controller is used to improve the ride comfort. The numerical results, verifies that the presented fuzzy logic controller improves the ride comfort.

Keywords—Ride comfort, air spring, bus, fuzzy logic controller.

I. INTRODUCTION

IN recent years, rapid improvements in the automotive industry have made people demand more for ride comfort. Especially on buses ride comfort become more and more important. Vibrations, caused by road roughness affect the ride comfort adversely. These vibrations can be minimized by using semi-active [1] and active suspension systems [2]. In this study, an active control strategy was applied to the bus suspension system. Fuzzy logic controllers were used on this system with a fixed number of auxiliary chambers. Fuzzy logic control was preferred since it has a model-free design methodology, and it can be applied to most systems successfully.

II. THE BUS MODEL WITH SEVEN DEGREES OF FREEDOM

The physical model of the bus is presented in Fig. 1

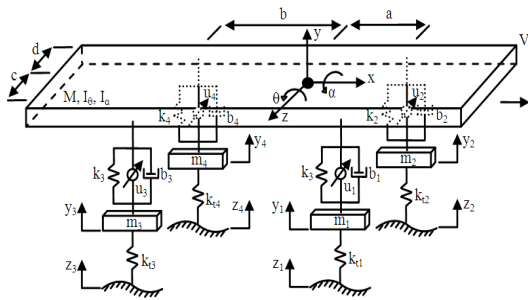

Fig. 1 The full-bus model

a, b, c and d are the distances from the body inertia of each rear and front axles; z_1, z_2, z_3, z_4 are the front and rear wheel road surface inputs; $k_{11}, k_{12}, k_{13}, k_{14}$ are the stiffness of front and rear wheels; m_1, m_2, m_3, m_4 are front and rear unsprung

masses; y_1, y_2, y_3, y_4 are front and rear wheel hops; k_1, k_2, k_3, k_4 are front and rear suspension spring constants; b_1, b_2, b_3, b_4 are front and rear suspension damping coefficients; u_1, u_2, u_3, u_4 are control inputs to the front and rear of the vehicle; y is body bounce; θ and α are body pitch and roll angles; I_0 and I_a are body inertias of pitch and roll, respectively.

The air spring model proposed by Bal [3] is used in this study. It can be designed to have different spring constants while carrying the same load. This is achieved by using auxiliary chambers which can be added to or separated from the air spring volume [4]-[6]. The air spring model with auxiliary chamber is shown in Fig. 2.

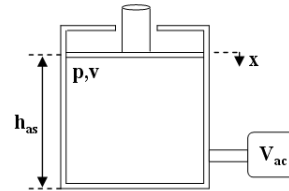

Fig. 2 Air spring model with auxiliary chamber

Here p is the pressure and v is the volume of air spring at time t ; V_{ac} is volume of auxiliary chamber; h_{as} is height of air spring; x is displacement of the air spring. Accordingly, the spring constant of the air spring is

$$k = nMgA_{as}(h_{as}A_{as} + n_{ac}V_{ac})^n [(h_{as}A_{as} + n_{ac}V_{ac}) - A_{as}x]^{-(n+1)} \quad (1)$$

- n : Polytrophic exponent
- M : Body mass
- g : Acceleration of gravity
- A_{as} : Area of auxiliary chamber
- n_{ac} : Number of auxiliary chamber

III. THE FUZZY LOGIC CONTROLLER

In this study, a fuzzy logic controller is used to improve the ride comfort. The algorithm of the multi-input single-output fuzzy logic controller for the vehicle suspension system uses the errors of suspension gap velocities $e(\dot{x}_i - \dot{y}_i)$, the errors of the suspension end at body chassis velocities $e(\dot{x}_i)$ and their accelerations $e(\ddot{x}_i)$ as the input variables [7].

The range of membership functions has been chosen as (-1, 1) and scaling factors are used in order to map the crisp input output values to their corresponding fuzzy values. Membership functions are shown in Fig. 3. Based on the three membership functions for each input, seventy-five rules may

M. Turkkan and N. Yagiz are with the Department of Mechanical Engineering, Istanbul University, Avcilar, Istanbul, Turkey (e-mail: mujde@istanbul.edu.tr, nurkany@istanbul.edu.tr).

be formulated. A model of the rule base developed for the front right suspension is given in Table I. P, N, ZE, VB, B, M and S represent Positive, Negative, Zero, Very Big, Big,

Medium and Small, respectively. For the each suspension same rule base is used.

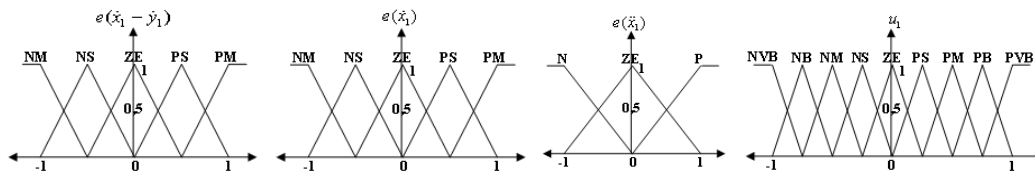

Fig. 3 Membership function plots of front right of the vehicle body

TABLE I
FUZZY ASSOCIATIVE MEMORY (FAM) [7]

$e(\dot{x}_1 - \dot{y}_1)$	$e(\dot{x}_1)$	$e(\ddot{x}_1)$	u_1	$e(\dot{x}_1 - \dot{y}_1)$	$e(\dot{x}_1)$	$e(\ddot{x}_1)$	u_1
PM	PM	ZE	ZE	PM	PM	P or N	PS
PS	PM	ZE	PS	PS	PM	P or N	PM
ZE	PM	ZE	PM	ZE	PM	P or N	PB
NS	PM	ZE	PM	NS	PM	P or N	PB
NM	PM	ZE	PB	NM	PM	P or N	PVB
PM	PS	ZE	ZE	PM	PS	P or N	PS
PS	PS	ZE	PS	PS	PS	P or N	PM
ZE	PS	ZE	PS	ZE	PS	P or N	PM
NS	PS	ZE	PM	NS	PS	P or N	PB
NM	PS	ZE	PM	NM	PS	P or N	PB
PM	ZE	ZE	NS	PM	ZE	P or N	NM
PS	ZE	ZE	ZE	PS	ZE	P or N	NS
ZE	ZE	ZE	ZE	ZE	ZE	P or N	ZE
NS	ZE	ZE	ZE	NS	ZE	P or N	PS
NM	ZE	ZE	PS	NM	ZE	P or N	PM
PM	NS	ZE	NM	PM	NS	P or N	NB
PS	NS	ZE	NM	PS	NS	P or N	NB
ZE	NS	ZE	NS	ZE	NS	P or N	NM
NS	NS	ZE	NS	NS	NS	P or N	NM
NM	NS	ZE	ZE	NM	NS	P or N	NS
PM	NM	ZE	NB	PM	NM	P or N	NVB
PS	NM	ZE	NM	PS	NM	P or N	NB
ZE	NM	ZE	NM	ZE	NM	P or N	NB
NS	NM	ZE	NS	NS	NM	P or N	NM
NM	NM	ZE	ZE	NM	NM	P or N	NS

IV. NUMERICAL RESULTS

The bus model is assumed to travel at a certain speed V on a curved road of 120 m. radius and over the bump shown in Fig. 4. The bump parameters are presented in Appendix.

The vehicle passes over the bump after it travels on the curved road for two seconds. The vehicle bounce, pitch and roll motion and their accelerations are shown in Fig. 5. The frequency responses of the bus model are given in Fig. 6.

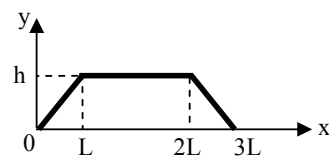

Fig. 4 Road disturbance input

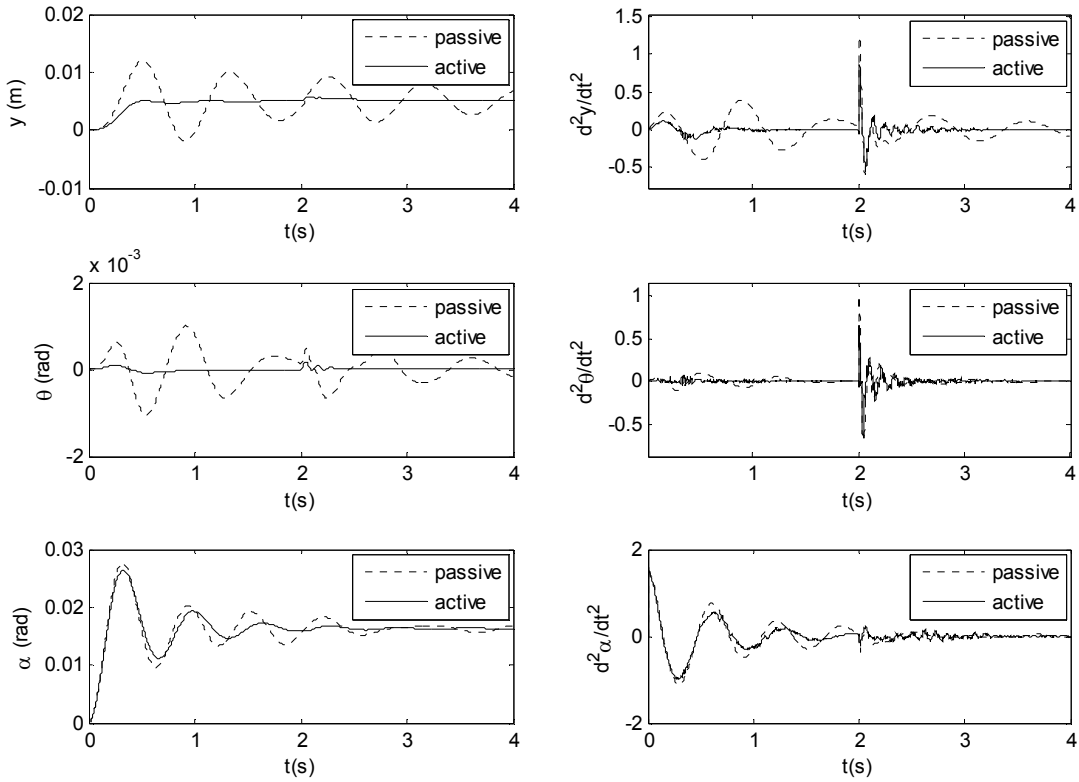

Fig. 5 Time response of the full-bus model

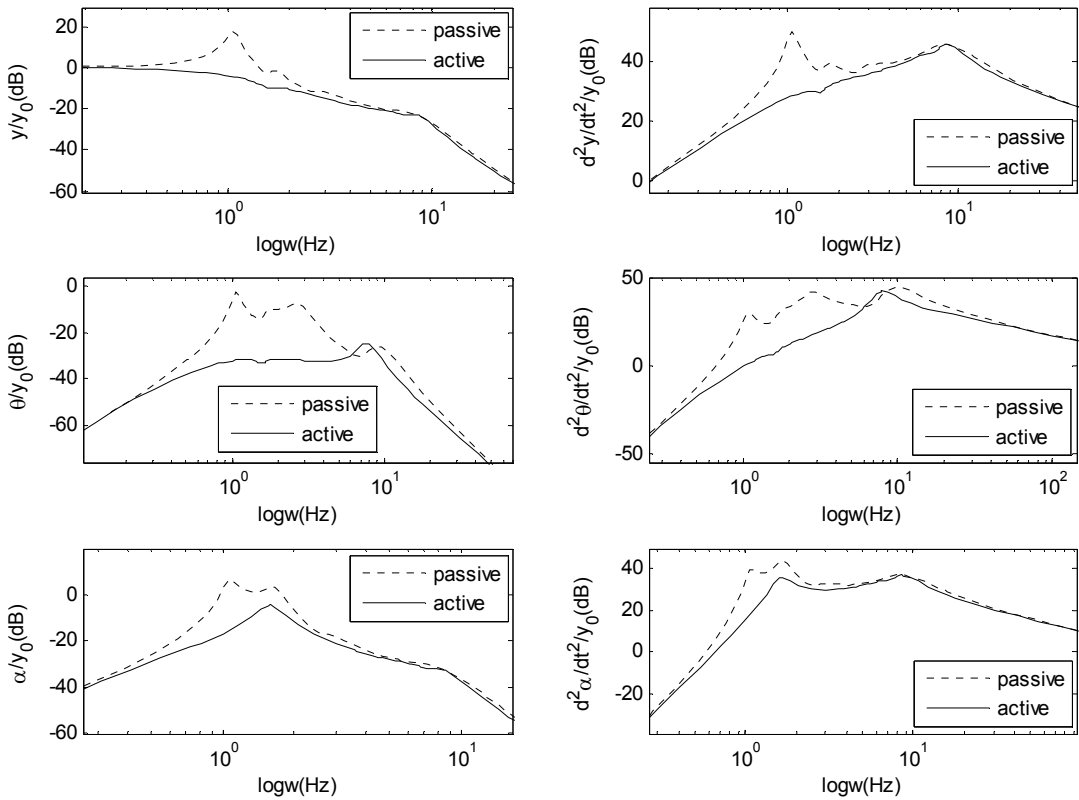

Fig. 6 Frequency response of the full-bus model

V. CONCLUSION

In this study, a fuzzy logic controller was designed for comfortable ride for a bus model using an air spring with auxiliary chambers. Controllers were placed parallel to suspensions. The bus model was assumed to travel over the bump. The time and frequency response plots were obtained. It is verified that the controller is capable of improving the ride comfort.

APPENDIX

TABLE II
PARAMETERS OF THE FULL-BUS MODEL

I_a	18819.4 kgm ²
I_0	33127.3 kgm ²
M	18000 kg
m_1, m_2	286 kg
m_3, m_4	473.5 kg
k_1, k_2, k_3, k_4	150000 N/m
b_1, b_2	9860 Ns/m
b_3, b_4	9520 Ns/m
k_{t1}, k_{t2}	870000 N/m
k_{t3}, k_{t4}	920000 N/m
a	3.853 m
b	2.022 m
c	1.714 m
d	0.982 m
V	50 km/h

TABLE III
PARAMETERS OF AIR SPRING [3]

n	1.2
d_{as}	0.2 m
h_{as}	0.4 m
V_{ac}	0.0031416 m ³

TABLE IV
PARAMETERS OF THE SPEED BUMP

h	0.035 m
L	0.025 m

The equations of motion are below:

$$\begin{aligned}
 & M \cdot \ddot{y} + k_1 \cdot (y + a \sin \theta - c \sin \alpha - y_1) \\
 & + k_2 \cdot (y + a \sin \theta + d \sin \alpha - y_2) \\
 & + k_3 \cdot (y - b \sin \theta - c \sin \alpha - y_3) \\
 & + k_4 \cdot (y - b \sin \theta + d \sin \alpha - y_4) \\
 & + b_1 \cdot (\dot{y} + a \cos \theta \dot{\theta} - c \cos \alpha \dot{\alpha} - \dot{y}_1) \\
 & + b_2 \cdot (\dot{y} + a \cos \theta \dot{\theta} + d \cos \alpha \dot{\alpha} - \dot{y}_2) \\
 & + b_3 \cdot (\dot{y} - b \cos \theta \dot{\theta} - c \cos \alpha \dot{\alpha} - \dot{y}_3) \\
 & + b_4 \cdot (\dot{y} - b \cos \theta \dot{\theta} + d \cos \alpha \dot{\alpha} - \dot{y}_4) = u_1 + u_2 + u_3 + u_4
 \end{aligned}$$

$$\begin{aligned}
 & I_x \cdot \ddot{\alpha} - c \cdot \cos \alpha \cdot k_1 \cdot (y + a \sin \theta - c \sin \alpha - y_1) \\
 & + d \cdot \cos \alpha \cdot k_2 \cdot (y + a \sin \theta + d \sin \alpha - y_2) \\
 & - c \cdot \cos \alpha \cdot k_3 \cdot (y - b \sin \theta - c \sin \alpha - y_3) \\
 & + d \cdot \cos \alpha \cdot k_4 \cdot (y - b \sin \theta + d \sin \alpha - y_4) \\
 & - c \cdot \cos \alpha \cdot b_1 \cdot (\dot{y} + a \cos \theta \dot{\theta} - c \cos \alpha \dot{\alpha} - \dot{y}_1) \\
 & + d \cdot \cos \alpha \cdot b_2 \cdot (\dot{y} + a \cos \theta \dot{\theta} + d \cos \alpha \dot{\alpha} - \dot{y}_2) \\
 & - c \cdot \cos \alpha \cdot b_3 \cdot (\dot{y} - b \cos \theta \dot{\theta} - c \cos \alpha \dot{\alpha} - \dot{y}_3) \\
 & + d \cdot \cos \alpha \cdot b_4 \cdot (\dot{y} - b \cos \theta \dot{\theta} + d \cos \alpha \dot{\alpha} - \dot{y}_4) = -cu_1 + du_2 - cu_3 + du_4
 \end{aligned}$$

$$\begin{aligned}
 & I_y \cdot \ddot{\theta} + a \cdot \cos \theta \cdot k_1 \cdot (y + a \sin \theta - c \sin \alpha - y_1) \\
 & + a \cdot \cos \theta \cdot k_2 \cdot (y + a \sin \theta + d \sin \alpha - y_2) \\
 & - b \cdot \cos \theta \cdot k_3 \cdot (y - b \sin \theta - c \sin \alpha - y_3) \\
 & - b \cdot \cos \theta \cdot k_4 \cdot (y - b \sin \theta + d \sin \alpha - y_4) \\
 & + a \cdot \cos \theta \cdot b_1 \cdot (\dot{y} + a \cos \theta \dot{\theta} - c \cos \alpha \dot{\alpha} - \dot{y}_1) \\
 & + a \cdot \cos \theta \cdot b_2 \cdot (\dot{y} + a \cos \theta \dot{\theta} + d \cos \alpha \dot{\alpha} - \dot{y}_2) \\
 & - b \cdot \cos \theta \cdot b_3 \cdot (\dot{y} - b \cos \theta \dot{\theta} - c \cos \alpha \dot{\alpha} - \dot{y}_3) \\
 & - b \cdot \cos \theta \cdot b_4 \cdot (\dot{y} - b \cos \theta \dot{\theta} + d \cos \alpha \dot{\alpha} - \dot{y}_4) = au_1 + au_2 - bu_3 - bu_4
 \end{aligned}$$

$$\begin{aligned}
 & m_1 \cdot \ddot{y}_1 - k_1 \cdot (y + a \sin \theta - c \sin \alpha - y_1) \\
 & + k_{t1} \cdot (y_1 - z_1) - b_1 \cdot (\dot{y} + a \cos \theta \dot{\theta} - c \cos \alpha \dot{\alpha} - \dot{y}_1) = -u_1
 \end{aligned}$$

$$\begin{aligned}
 & m_2 \cdot \ddot{y}_2 - k_2 \cdot (y + a \sin \theta + d \sin \alpha - y_2) \\
 & + k_{t2} \cdot (y_2 - z_2) - b_2 \cdot (\dot{y} + a \cos \theta \dot{\theta} + d \cos \alpha \dot{\alpha} - \dot{y}_2) = -u_2
 \end{aligned}$$

$$\begin{aligned}
 & m_3 \cdot \ddot{y}_3 - k_3 \cdot (y - b \sin \theta - c \sin \alpha - y_3) \\
 & + k_{t3} \cdot (y_3 - z_3) - b_3 \cdot (\dot{y} - b \cos \theta \dot{\theta} - c \cos \alpha \dot{\alpha} - \dot{y}_3) = -u_3
 \end{aligned}$$

$$\begin{aligned}
 & m_4 \cdot \ddot{y}_4 - k_4 \cdot (y - b \sin \theta + d \sin \alpha - y_4) \\
 & + k_{t4} \cdot (y_4 - z_4) - b_4 \cdot (\dot{y} - b \cos \theta \dot{\theta} + d \cos \alpha \dot{\alpha} - \dot{y}_4) = -u_4
 \end{aligned}$$

REFERENCES

- [1] N. Al-Holou, A. Bajwa and D. S. Joo, "Computer Controlled Individual Semi-Active Suspension System", Circuits and Systems, Vol.1, 1993, pp 208–211.
- [2] N. Yagiz, Y. Hacioglu, Y. Taskin, "Fuzzy Sliding-Mode Control of Active Suspensions", Industrial Electronics, Vol. 55, 2008, pp 3883–3890.
- [3] H. Bal, "Theoretical Investigation of the Performances of The Semi-active Suspension Systems with Air Springs and Comparison with Mechanical Suspensions", M. Sc. Thesis, Gazi University Institute of Science and Technology, 2006.
- [4] Z. Sihong, W. Jiasheng, Z. Ying, "Research on Theoretical Calculation Model for Dynamic Stiffness of Air Spring with Auxiliary Chamber", Vehicle Power and Propulsion Conference, 2008, pp. 1–6.
- [5] K. Toyofuku, C. Yamada, T. Kagawa, T. Fujita, "Study on Dynamic Characteristic Analysis of Air Spring with Auxiliary Chamber", Journal of Sound and Vibration, Vol. 20, 1999, pp 349–355.
- [6] G. Quaglia, M. Sorli, "Air Suspension Dimensionless Analysis and Design Procedure", Vehicle System Dynamics, Vol. 35, No. 6, 2001, pp 443–475.
- [7] N. Yagiz, L.E. Sakman, "Fuzzy Logic Control of A Full Vehicle without Suspension Gap Degeneration", Int. J. Vehicle Design, 42, 2006, pp. 198–212.