

A Low Cost and High Quality Duty-Cycle Modulation Scheme and Applications

B. Lonla Moffo, J. Mbihi, L. Nneme Nneme

Abstract—In this paper, a low cost duty-cycle modulation scheme is studied in depth and compared to the standard pulse width modulation technique. Using a mix of analytical reasoning and electronics simulation tools, it is shown that under the same operating conditions, most characteristics of the proposed duty-cycle modulation scheme are better than those provided by a standard pulse width modulation technique. The simulation results obtained when testing both modulation control policies on prototyping systems, indicate that the proposed duty-cycle modulation approach, appears to be a high quality control policy in a wide variety of application areas, including A/D and D/A conversion, signal transmission and switching control in power electronics.

Keywords—Duty-cycle Modulation, Operational amplifiers, Pulse width modulation, Power electronics, Signal processing.

I. INTRODUCTION

THE duty-cycle modulation (DCM) is used in industrial electronics, as a special signal processing technique with a switching periodic output wave. As an implication, the duty-cycle of the modulated wave evolves according to a known function of the modulating input ([1], [2]). A variety of DCM architectures are encountered in the literature [1], each of which being characterized on by a given hardware architecture and a specific duty-cycle structure. Really speaking, the pulse width modulation (PWM) is a subclass of DCM techniques with constant modulation frequency. It is widely used in power control electronics ([3]-[7]) as a very efficient means for controlling the power flow delivered to a load. It is used also in instrumentation engineering for the implementing of a class of analog-to-digital (A/D) and digital-to-analog (D/A) converters ([8]-[14]).

However, although the PWM technique remains very popular in a variety of application areas, the aim of this paper is to outline the attractive characteristics of the proposed DCM scheme compared to the PWM weaknesses.

J. Mbihi is with the Research laboratory of industrial computer sciences and automation engineering, in the Advanced Teachers Training College (ATTCO) for Technical Education, University of Douala, Cameroon (e-mail: mbihidr@yahoo.fr).

B. Lonla Moffo is with the Research laboratory of industrial computer sciences and automation engineering, in the ATTCO for technical education of the University of Douala, and with the Department of electrical and electronics engineering of the College of Technology, University of Buea, Cameroon (e-mail: moffolb@yahoo.fr).

L. Nneme Nneme is with the Research laboratory of industrial computer sciences and automation engineering, in the ATTCO for technical education, University of Douala, Cameroon (e-mail: leandren@gmail.com).

The remaining of this paper is organized as follows: In Section II, the architecture of the proposed DCM scheme and that of the standard PWM technique are presented for the sake of comparison. In Section III, the frequency analysis of the modulated wave provided in each case is conducted. Then, the results obtained when testing both modulation control policies on recent and new application areas are outlined in Section IV, whereas a comparative analysis between the two modulation techniques is done in Section V, in order to outline the merits of DCM principles and properties.

II. ARCHITECTURE OF MODULATION SCHEMES

The standard PWM and the proposed DCM schemes are presented in Fig. 1 for the sake of comparative study. Without loss of generality, the common technology retained for the implementation of both modulation techniques, is based on the use of integrated operational amplifiers.

The DCM modulation circuit shown in Fig. 1 (a) has been selected from the class of modulation circuits studied in reference [2] for signal conditioning in industrial instrumentation. It is built using a controlled negative resistance oscillator connected to a linear capacitance, whereas the standard PWM circuit described in Fig. 1 (b) consists of a switching comparator with two inputs (triangle wave and modulating control signal).

It is important to observe that the hardware complexity of a PWM circuit is greater than that of the DCM cell. Another important remark between the two is that, the modulation period T_m^{PWM} or frequency f_m^{PWM} equivalently, is constant at the output of a PWM circuit. Conversely, in the case of DCM technique, the period $T_m^{DCM}(u)$ or frequency $f_m^{DCM}(u)$ evolves according to the variation of the control input u , with a maximum value reached when the control input is set to $u = 0$ volt (see Appendix 1 for details).

The common behavior between DCM and PWM techniques is that, the resulting output modulated signals provided in each case is a switching periodic waveform. As it will be seen later in this paper, a set of attractive properties is hidden behind the structural simplicity of the proposed DCM circuit. Furthermore, the resulting duty-cycle associated with each switching periodic modulated wave as drawn in Fig. 1 is given by:

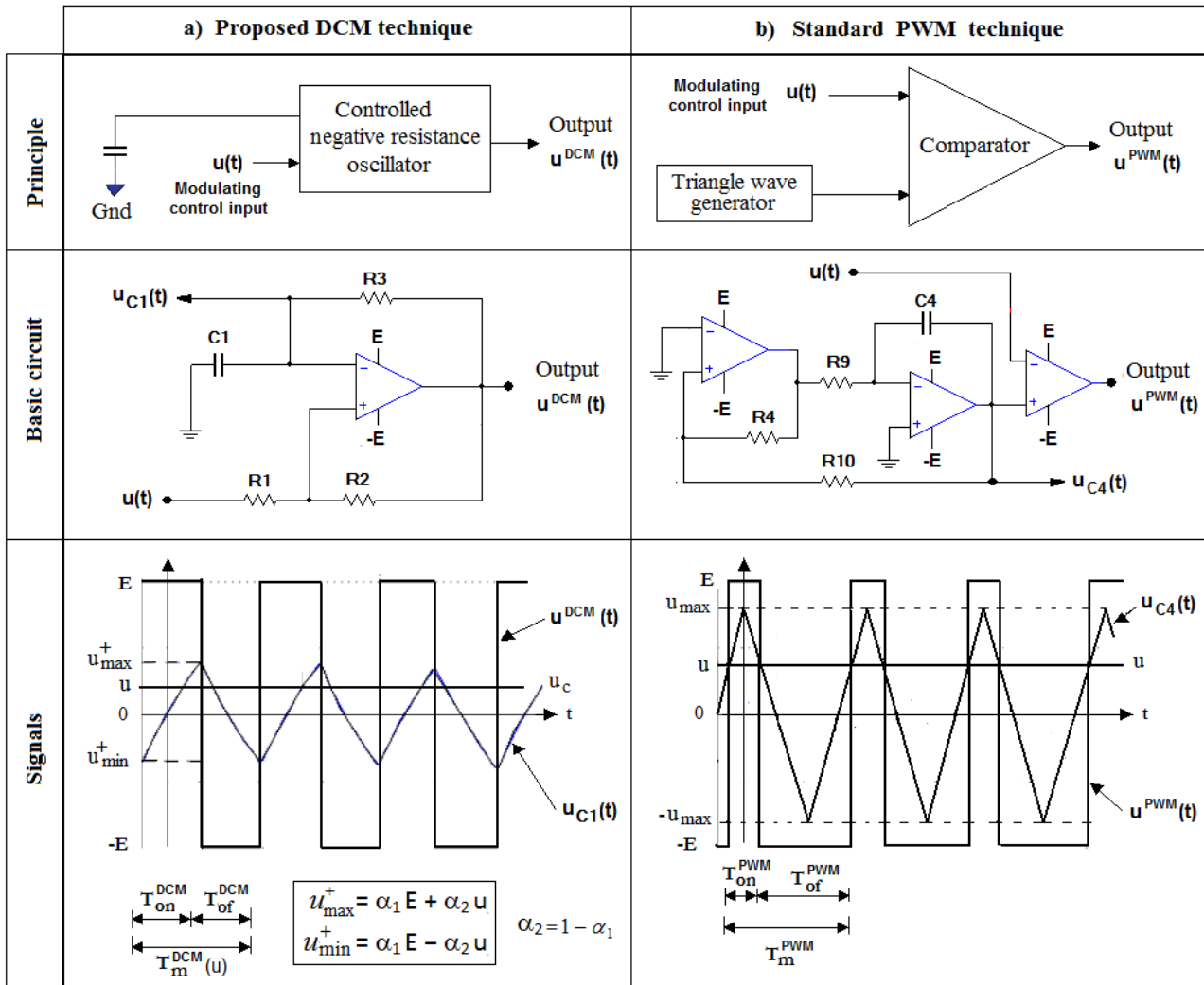

Fig. 1 (a) Basic DCM circuits considered in this paper (b) Basic PWM circuits considered in this paper

$$R_m^X(u) = \begin{cases} \frac{T_{on}^X(u)}{T_m^X(u)} & \text{for } X = DCM \\ \frac{T_{on}^X(u)}{T_m^X(u)} & \text{for } X = PWM \end{cases} \quad (1)$$

control with intrinsic design parameters. Thus, in the case of DCM, the duty-cycle could be computed after a straightforward development as in [15]:

$$R_m^{DCM}(u) = p_m^{DCM} u + \frac{1}{2} \quad (3.a)$$

Although the modulation period $T_m^{DCM}(u)$ depends on the control input u , its minimum value $T_m^{DCM}(0)$ is achieved for $u = 0$. It is assumed in this paper that both modulation circuits presented in Fig. 1 have equal basic clock frequencies given by (see Appendix 1):

$$1/T_m^{DCM}(0) = 1/T_m^{PWM} \quad (2)$$

with,

$$p_m^{DCM} = \frac{1}{2} \frac{\alpha_1(1-\alpha_1)}{E(1-\alpha_1^2)} \log\left(\frac{1+\alpha_1}{1-\alpha_1}\right), \quad \alpha_1 = \frac{R_1}{R_1+R_2} \quad (3.b)$$

In addition, within a sufficiently wide neighborhood of the fixed point $(0, R_m^X(0))$, the duty-cycle function provided in each case behaves as linear function of the related modulating

In the case of PWM circuit, the duty-cycle could be computed as follows [16]:

$$R_m^{PWM}(u) = p_m^{PWM} u + \frac{1}{2} \quad (4.a)$$

with,

$$p_m^{PWM} = -\frac{1}{2 u_{max}} = -\frac{1}{2 E} \left(\frac{R_4}{R_{10}} \right) \quad (4.b)$$

III. FREQUENCY CHARACTERISTICS OF MODULATED WAVES

The Fourier series of modulated waves presented in Fig. 1, are given by:

$$U_m^X(u, t) = \underbrace{\left(2 R_m^X(u) - 1 \right) E}_{C_X(0,u): \text{Low frequency term}} + \sum_{n=1}^{\infty} \underbrace{\left(\frac{4 E}{\pi} \right) \frac{\sin(n\pi R_m^X(u))}{n}}_{C_X(n,u)} \cos \left(2 \pi n \frac{t}{T_m^X(u)} \right) \quad (5)$$

High frequency terms

where the subscript X stands for DCM or PWM policy. Given equations (3) and (4), the modulating signals could be recovered in each case from (5) using appropriate low-pass filters with static gains:

$$K_f^{DCM} = \frac{(1 - \alpha_1^2)}{2 \alpha_1 (1 - \alpha_1)} \log \left(\frac{1 + \alpha_1}{1 - \alpha_1} \right) \quad (6.a)$$

$$K_f^{PWM} = -\frac{u_{max}}{E} = -\frac{R_{10}}{R_4} \quad (6.b)$$

For the sake of better comparison of the spectra of DCM and PWM waves, we resort here to the concept of normalized spectrum. A normalized spectrum is obtained from the amplitude compression of harmonics. The related normalized amplitudes are defined from (5) given (3) or (4) as follows:

$$C_X^{Norm}(n, u) = \frac{C_X(n, u)}{C_X(1, u)} = \frac{\text{Sin} \left(n \pi p_m^X u + \frac{1}{2} \right)}{\text{Cos}(\pi p_m^X u)} \quad (7)$$

For $n = 1, 2, \dots$, where the subscript X stands for DCM or PWM policy, and p_m^X been given by (3) or (4). Thus, in the admissible modulating range, the normalized amplitude related to the first harmonics is 1 for any control input u .

Given the modulation schematic diagrams drawn in Fig. 1, the absolute spectrum of modulated outputs resulting from (5), has been simulated with the help of Matlab, in the modulating range [-2 2] volts. The values of components labeled on each schematic diagram, have been appropriately chosen in order to maintain the same operating conditions (input modulating range [-2 2] volts, and equal basic frequencies) for both

modulation circuits. A mayor discovery emerging from the simulation results presented in Fig. 2 is that, under the same operating conditions, the spectrum of the DCM output signal is better in terms of rapid convergence and monotonous trend, than that of the PWM output wave.

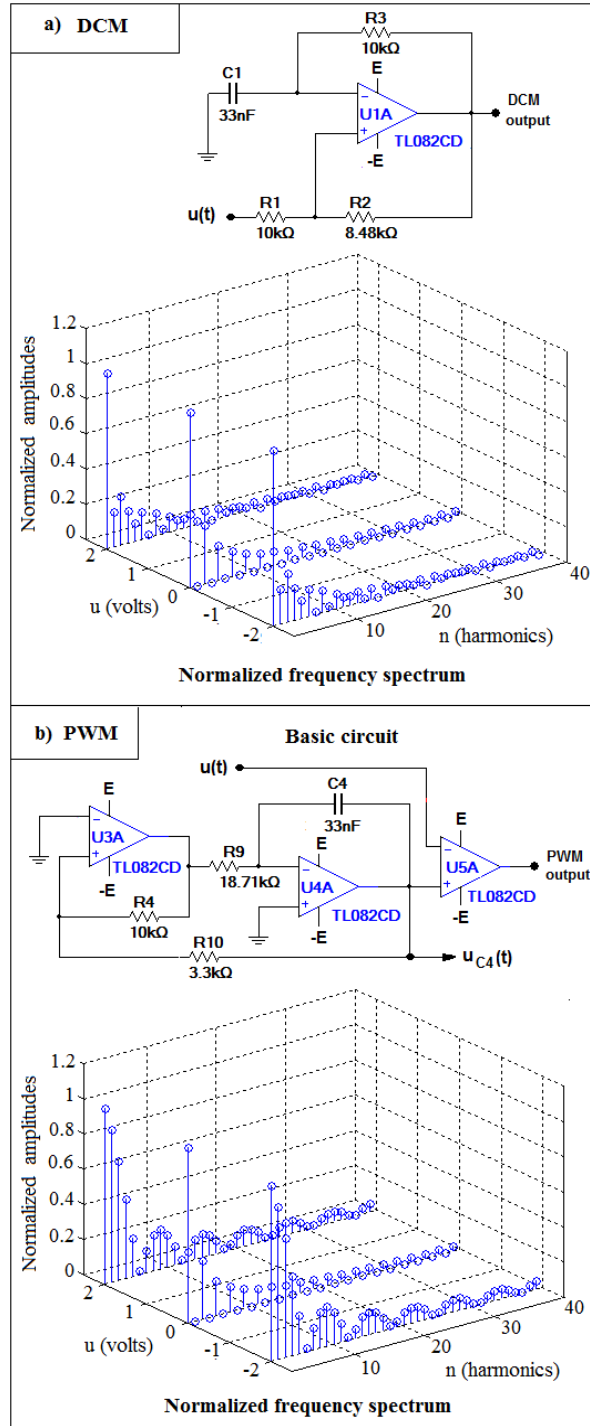

Fig. 2 (a) Spectral representation of DCM signal (b) Spectral representation of PWM signals

As an implication, the rapid convergence of the DCM spectrum, along with the fact that the DCM period $T_m^{DCM}(u)$ depends on the modulating input, appear to be new attractive properties for a variety of application areas investigated in the Section IV.

IV. APPLICATIONS AREAS OF THE PROPOSED DCM TECHNIQUE

A. Recent Application Areas

Recent research works have shown the great merits of the DCM principle and characteristics, when using for the implementation of novel *analog-to-digital* (A/D) and *digital-to-analog* (D/A) converters in [17], [18] and [19] respectively. Following the findings emerging from these pioneering works, the challenge brought by DCM-based A/D and D/A converters among most existing signal conversion A/D and D/A techniques (including PWM-based technique), relies on the fact that the DCM technology offers minimum hardware cost, while providing minimum digital processing complexity. Furthermore, in power electronics, a DCM device has been used and well tested in [20], as a better switching controller for Buck power converters.

B. A New Application Area

The new application area of interest of the DCM technique explored in this section is a transmission system presented in Fig. 3. Both DCM and PWM are considered for the sake of comparison. It is assumed the transmission line is lossless in each case. In addition, the demodulation circuits used are second order low-pass filters, with appropriate static gains K_f^{DCM} or K_f^{PWM} given by (6), and the same cut-off frequency. Since $K_f^{DCM} > 1$ and $K_f^{PWM} < -1$, an inverter is necessary at the output stage of the PWM filter.

Given the 3D spectra of both DCM and PWM presented in Fig. 2, it is obvious to predict that, if the common cut-off frequency of demodulation filters, is sufficiently greater compared to the modulating frequency range, then both DCM and PWM modulation techniques should provide similar outputs $y_{DCM}(t)$ and $y_{PWM}(t)$ respectively. Otherwise, using numerical simulations, it is interesting to analyze what would happens under an increase of the modulation frequency range for a fixed cut-off frequency associated with these equivalent filters. The comparative results presented from Figs. 4 to 5, have been obtained using National Instrument *Multisim* software.

In Fig. 4, the modulating input is set to $u(t) = 2 \sin(10 \pi t)$. As a result, Figs. 4 (a) and (b) present a zoomed view of modulation signals (ic_1, u_m^{DCM}) and (ic_4, u_m^{PWM}) respectively. In Figs. 4 (c) and (d), the DCM and PWM techniques provide similar behaviors in terms of both the shape and the overall delay related to output waves $y_{DCM}(t)$ in Fig. 4 (c) and $y_{PWM}(t)$ in Fig. 4 (d) respectively. In addition, Fig. 5 shows how in the PWM case, an increase of the modulating frequency yields

greater decreasing effects on the amplitude of the output wave $y_{PWM}(t)$. In addition, the shape of $u_m^{PWM}(t)$ as observed on Fig. 4 (a) shows that, its mean behavior is a sine wave with the same frequency as the modulating control. However, this impressive phenomenon, is not apparent on the graph of the output wave $y_{PWM}(t)$ provided in Fig. 4 (b).

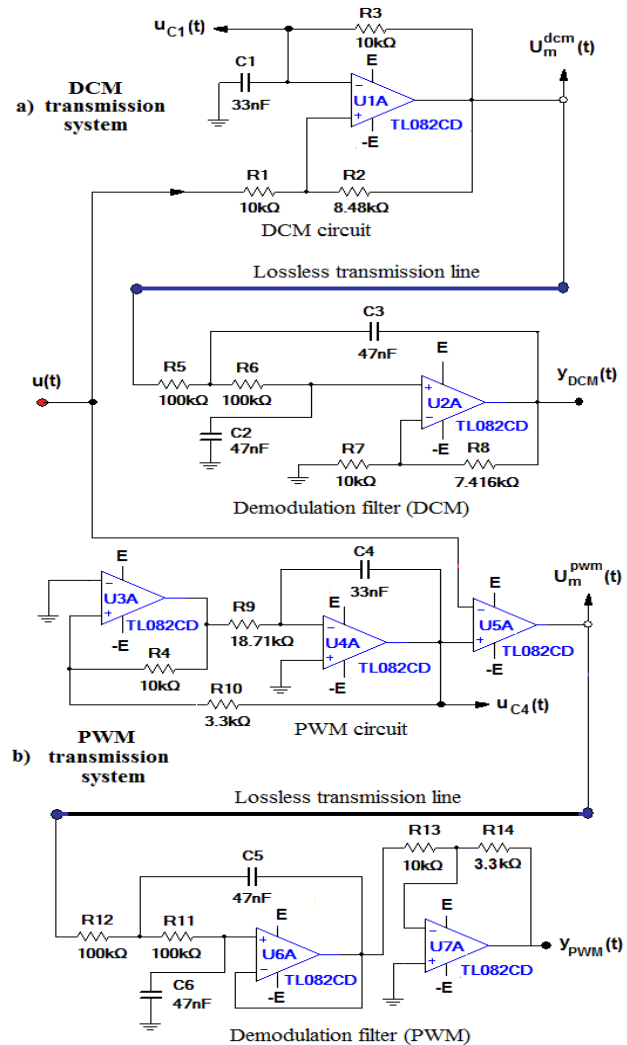

Fig. 3 Prototyping lossless transmission system

C. Comparative Study of DCM and PWM Techniques

Table I presents a summary of the comparative study between the characteristics of DCM and PWM techniques. The main target application areas of PWM and DCM techniques are listed in the first colon, whereas the comparative criteria retained for each application area written in the second colon. The characteristics of both standard PWM and DCM techniques are provided also in the third and fourth colons respectively.

The results emerging from comparative studies indicate that, among a set of 10 criteria retained for a variety of application areas, the DCM technique provides less weaknesses. Thus, it

might become a more suitable modulation control policy in most application areas where PWM is commonly used today.

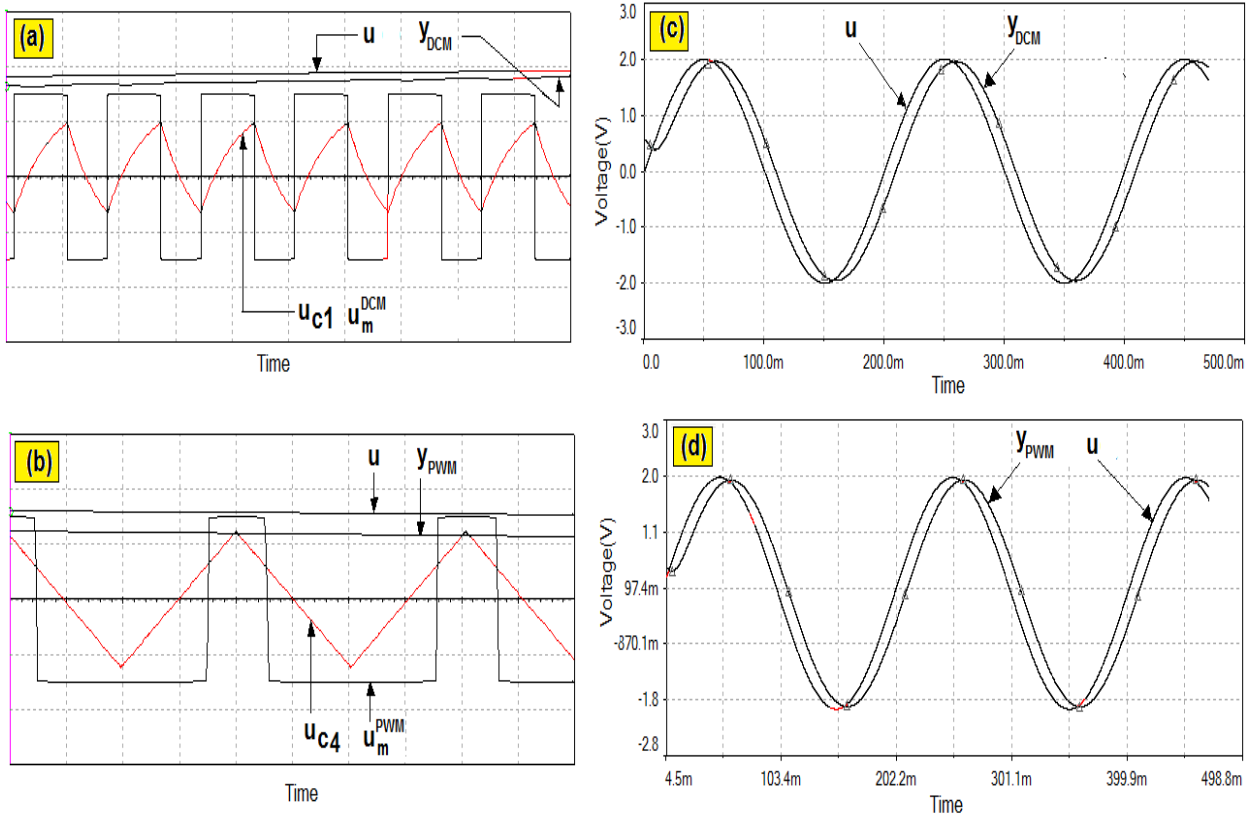

Fig. 4 Simulation of transmission systems for a low frequency input $u(t) = 2 \sin(10\pi t)$. (a) Zoomed view of DCM's modulation signals (b) Zoomed view of PWM's modulation signals (c) DCM input and output wave (d) PWM input and output wave

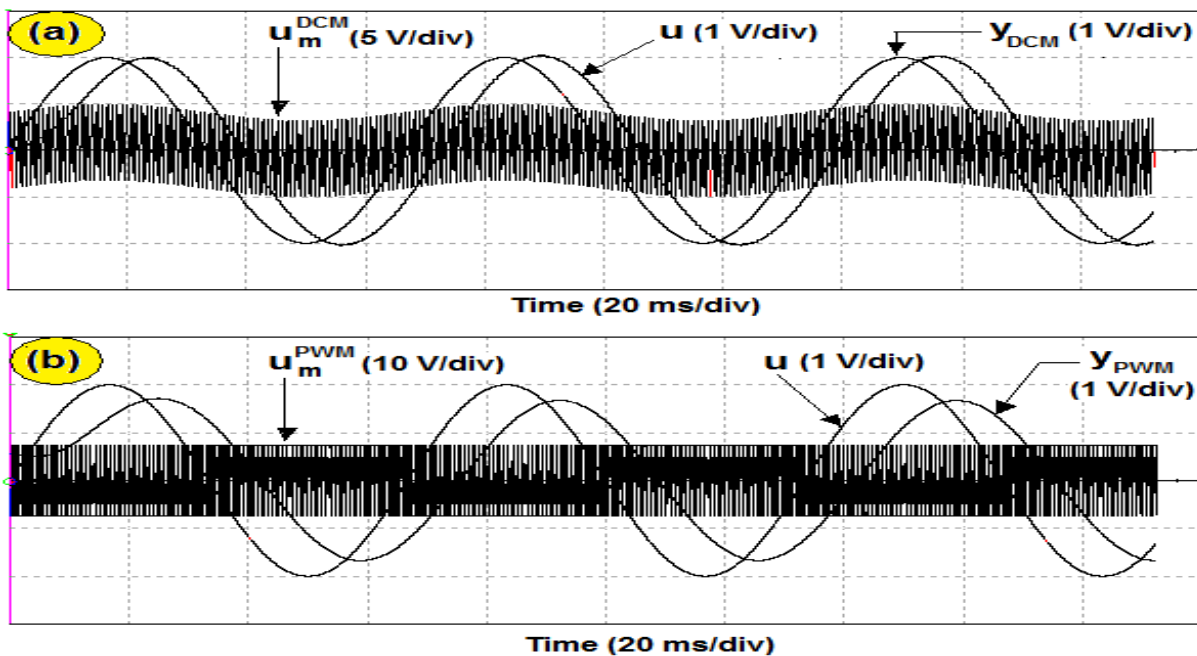

Fig. 5 Simulation of transmission systems for an increase in the modulating frequency

TABLE I
COMPARATIVE STUDY OF DCM AND PWM TECHNIQUES UNDER THE SAME OPERATIONAL CONDITIONS

Application area	Comparative criteria	PWM technique	Proposed DCM technique
A/D conversion	1 Hardware complexity and cost	Higher	Lower
	2 Oversampling cost	Higher	Lower
	3 Digital demodulation cost	Lower	Lower
D/A conversion	4 Digital processing cost (from Fourier series)	Higher	Lower
	5 Complexity of the hardware conversion logic	Higher	Lower
Buck converter control	6 Hardware complexity	Higher	Lower
	7 High frequency stresses on power switches	Higher	Lower
Signal transmission	8 Number of operational amplifiers	Higher	Lower
	9 Modulating bandwidth	Lower	Higher
	10 Nonlinear range of the duty-cycle function	Lower	Higher

V. CONCLUSION

This paper has studied in depth the attractive properties of a proposed low cost and high quality DCM technique. It fundamentally differs from standard PWM principle since the modulation frequency involved depends on the modulating input. Compared under the same operating conditions to the standard PWM policy with a fixed modulation frequency, the DCM technology provides better characteristics in most application areas where they have been well tested.

The contribution of this paper has been to outline a few weaknesses of the standard PWM modulation technique, even though it remains commonly used today in most application areas. Thus, the challenge of DCM techniques results from both its architectural simplicity and high quality due to a better behavior of the modulation frequency spectrum.

It will be very fruitful to extend the use of DCM techniques to the control of other types of switching DC-DC power converters, and to the control of power DC-AC inverters with great emphasis on electronic starters for both synchronous and induction machines. It will be interesting also to developed DCM devices and drivers using FPGA-based embedded technology. These aforementioned issues appear to be potential opportunities for future research works.

APPENDIX 1

SHAPE OF DCM AND PWM MODULATION FREQUENCIES

Recall that the PWM frequency f_m^{PWM} is constant while the DCM frequency $f_m^{DCM}(u)$ is dictated by the modulating input u . A straightforward analysis of the DCM circuit presented in Figs. 1 (a) or 2 (a) equivalently, leads to:

$$T_m(u) = \tau \ln \left(\frac{(\alpha_2 u)^2 - ((1 + \alpha_1)E)^2}{(\alpha_2 u)^2 - ((\alpha_1 - 1)E)^2} \right)$$

$$\text{with } \tau = R_3 C_1 \text{ and } \alpha_1 = \frac{R_1}{R_1 + R_2}$$

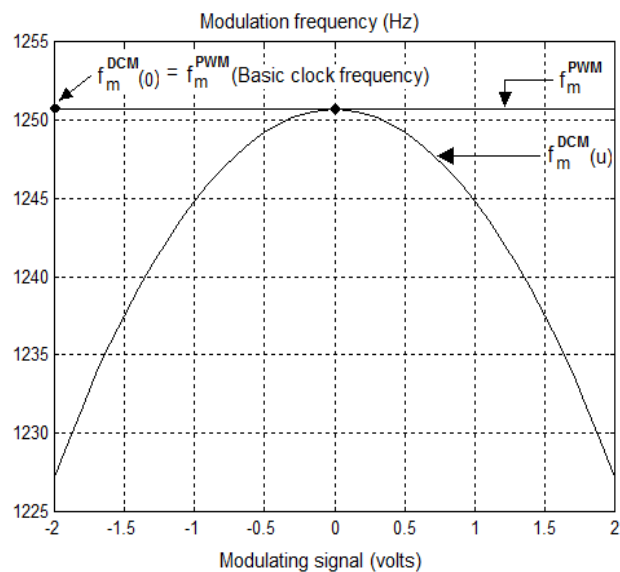

Fig. 6 The shape of DCM and PWM modulation frequency

REFERENCES

- [1] E. Roza, "Analog-to-digital conversion via duty-cycle modulation", IEEE transactions on circuits and systems II: Analog and digital signal processing, Vol. 44, No. 11, pp. 907-914, 1997.
- [2] J. Mbihi, F. Ndjali Beng and M. Mbouenda, "modelling and simulation of a class of duty-cycle modulators for industrial instrumentation", Iranian Journal of Electrical and Computer engineering, Vol. 4, No. 2, pp. 121-128, 2005.
- [3] Joachim Holtz, "Pulse width modulation - a survey", IEEE transactions on industrial electronics, vol. 39, no. 5, pp. 410-420, December 1992.
- [4] G. C. Ioannidis a, G. Charokopos b, P. Marabeas b & S. N. Manias, "A mixed-mode PWM controller", International Journal of Electronics, Vol. 97, No. 12, December 2010, 1423-1438
- [5] T. D. Batzel and Mihai Comanescu, "Instantaneous voltage measurement technique for PWM voltage source inverter", International Journal of Power Electronics, Vol. 1, No 1, pp. 1-15, 2008.
- [6] M. A. Patel, Ankit R. Patel, Dhaval R. Vyas and Ketul M. Patel, "Use of PWM Techniques for Power Quality Improvement", International Journal of Recent Trends in Engineering, Vol. 1, No. 4, pp. 99-102, May 2009.
- [7] A. K. Dewangan, N. Chakraborty, S. Shukla, V. Yadu, "PWM based automatic closed loop speed control of DC motors", International Journal of engineering trends and technology", Vol. 3, Issue 2, pp. 110-112, 2012.
- [8] M. M. Abdel Aziz, "Simplified approaches for controlling DC-DC power converters", International Journal of Engineering sciences and Technology", Vol. 4, N° 2, pp. 792-803, February 2012.

- [9] A. Prodic, D. Maksimovic, r. W. Erickson, "Design and implementation of a digital PWM controller for a high frequency switching DC-DC power converter", The 27th annual conference of the IEEE Industrial Electronics Society, pp. 893-89, 2001.
- [10] G.C. Ioannidis, G. Charokopos, P. Marabeas and S.N. Manias, "A mixed-mode PWM controller", International Journal of Electronics, Vol. 97, No. 12, December 2010, 1423–1438
- [11] K. Daugherty, "Pulse width modulation A/D conversion techniques with COP800 family microcontrollers", Application note AN607, pp. 1-8, 1995.
- [12] Texas instrument, "Using PWM timer as a DAC", Application note SLAA116, pp. 1-20, December 2000.
- [13] Alera, "Controlling Analog Output From a Digital CPLD Using PWM", White paper WP-01085, Version 1.0, pp. 1-5, November 2008, www.altera.com.
- [14] Microchip, "D/A conversion using PWM and R-2R ladders to generate sine and DTMF signals", Application note AN655, pp. 1-11, Microchip.
- [15] J. Mbihi, F. Ndjali Beng, M. Kom, L. Nneme Nneme, "A Novel Analog-to-digital conversion Technique using nonlinear duty-cycle modulation", International Journal of Electronics and Computer Science Engineering, Volume 1, Number 3, pp 818-825, 2012. Technology inc, 1997.
- [16] J. Millman and A. Grabel, "Microelectronics", McGraw-Hill. 1001 p., 1987,
- [17] J. MBIHI et Alexis Motto "Informatique Industrielle - Instrumentation virtuelle assistée par ordinateur: Principes et techniques, Cours et exercices corrigés", 240 pages, Editions Ellipses, collection TechnoSup, 23 Octobre, 2012.
- [18] J. Mbihi, L. Nneme Nneme, "A Multi-Channel Analog-To-Digital Conversion Technique Using Parallel Duty-Cycle Modulation", International Journal of Electronics and Computer Science Engineering, Volume 1, Number 3, pp 826-833, 2012.
- [19] B. Lonla Moffo, J. Mbihi, L. Nneme Nneme, M. Kom, "A novel digital-to-analog conversion technique using duty-cycle modulation", International Journal of Circuits, Systems and Signal processin, Issue 1, Vol. 7, pp 42-49, May 2013, © North Atlantic University Union.
- [20] J. Mbihi, L. Nneme Nneme, "A novel Control Scheme for Buck Power Converters using Duty-Cycle Modulation", To appear in International Journal of Power Electronics, 2013.