

# A Variable Stiffness Approach to Vibration Control

S. A. Alotaibi, M. A. Al-Ajmi

**Abstract**—This work introduces a new concept for controlling the mechanical vibrations via variable stiffness coil spring. The concept relies on fitting a screw through the spring to change the number of active spring coils. A prototype has been built and tested with promising results toward an innovation in the field of vibration control.

**Keywords**—Variable stiffness, coil spring, vibration control.

## I. INTRODUCTION

VIBRATION control is a common engineering problem in major mechanical, aerospace and petrochemical industries. The vibration characteristics of any mechanical system are quantified by inertia, damping and stiffness [1]. Most of the vibration control methodologies rely on enhancing the damping properties of the system using passive damping techniques such viscoelastic treatments which are rubber-like additives [2], or active damping/control using sensors and actuators [3]. Another research direction is aimed toward changing the stiffness properties of the vibrating system. A semi-active variable stiffness device has been developed by changing the stiffness of a multi-spring configuration controlled by electromechanical actuator [4]. A semi-active stiffness system for seismic response control of structures has been proposed by Kobori et al. [5]. The system mainly controls the stiffness of a building to establish a non-resonance condition during earthquakes using a bracing system. In helical springs, the number of coils is the main factor that controls the stiffness constant. A patented device has been proposed to control the active coils in helical springs where a series of plates protrude between the coils of the spring [6]. Thus, controlling the active number of spring coils.

The aim of this paper is to introduce a new innovative design to control the active number of spring coils using a screw that fits inside the spring.

## II. CONCEPT

The stiffness constant  $k$  of a helical spring is defined by

$$k = \frac{1}{n} \left( \frac{Gd^4}{8D^3} \right) \quad (1)$$

where  $G$  is the shear modulus,  $d$  is the diameter of the spring

wire,  $D$  is the mean diameter of the spring coil and  $n$  is the number of coils. Practically, all parameters are preset except the length of the spring which can be specified by the number of coils. Hence, the concept relies on changing the active length which is determined by the freely moving spring coils. In this work, the number of free “active” coils is controlled by introducing a screw with threads having the shape of the spring as shown in Fig. 1. Once the screw moves through the spring, the spring coils fits in the screw thread and the active length (number of coils) of the spring is reduced resulting in higher spring stiffness as can also be seen from (1).



Fig. 1 Spring and locking screw

## III. PRELIMINARY RESULTS

An experiment has been setup to examine the new spring/screw device. As shown in Fig. 2, the experiment is basically a base excitation model where the base is harmonically excited by a motor-driven cam with a measured amplitude  $Y$ . The upper part of the prototype, which represents the main vibrating body, is connected to the base through the spring/screw and moves with amplitude  $X$ .

S. A. Alotaibi is an Associate Professor in the Mechanical Engineering Department, College of Engineering and Petroleum, Kuwait University, Safat, 13060, Kuwait (phone: +965-24987728; fax: +96524847131; e-mail: sr.alotaibi@gmail.com).

M. A. Al-Ajmi is an Associate Professor in the Mechanical Engineering Department, College of Engineering and Petroleum, Kuwait University, Safat, 13060, Kuwait (phone: +965-24987161; fax: +96524847131; e-mail: dr.alajmi@gmail.com).

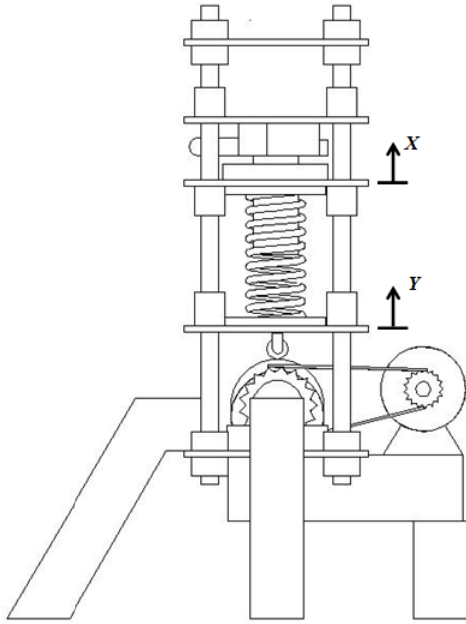

Fig. 2 Experimental Setup

The screw is driven through the spring coils using a step input from a motor which specifies the amount of rotation, hence the distance the screw moves through the spring. The experimental frequency response for  $n = 7$  is shown in Fig. 3, where  $r = \omega / \omega_n$  is the ratio of the excitation frequency  $\omega$  to the natural frequency of the system  $\omega_n$ .

The damping ratio is estimated to be  $\zeta = 0.194$  using the half power equation:

$$\zeta = \frac{\omega_2 - \omega_1}{2\omega_n} \quad (2)$$

where  $\omega_1$  and  $\omega_2$  are the half power frequencies measured at  $X/\sqrt{2}$ .

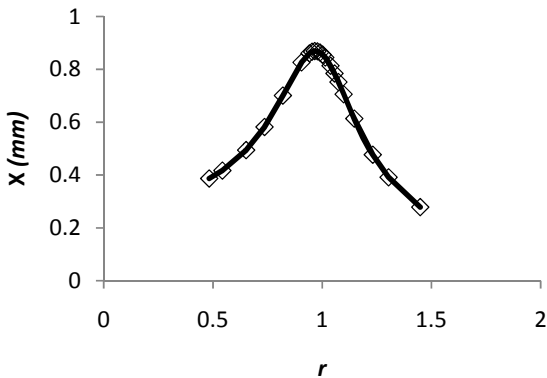

Fig. 3 Experimental response of the system for  $n = 7$

The stiffness of the spring is calculated experimentally using the slope of the spring load/displacement curve to be  $k = 6450$  N/m. The theoretical response of the system is given by:

$$X = Y \sqrt{\frac{1+(2\zeta r)^2}{(1-r^2)^2+(2\zeta r)^2}} \quad (3)$$

The response at different values of  $n$  is shown in Fig. 4 for two different excitation frequencies. It can be clearly seen from the figure that the number of coils plays a major role in altering the response of the system by changing the natural frequency of the system through the stiffness of the coil spring since  $\omega_n = \sqrt{k/m}$ .

The experimental response of the system is shown in Fig. 5 for the same excitation frequencies that have been used to calculate the theoretical response. The experimental amplitude differs from the theoretical one due to the oversimplified single degree of freedom model.

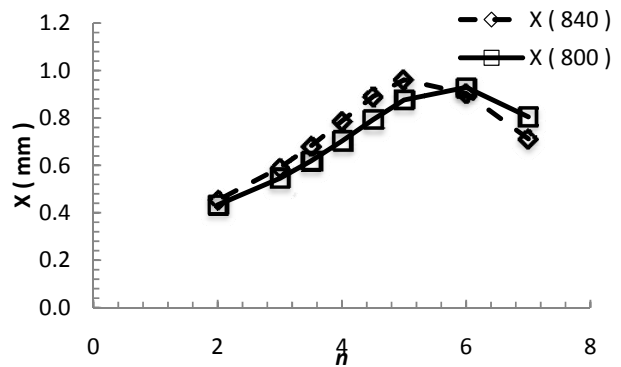

Fig. 4 Theoretical response versus number of coils for two different excitation frequencies: 800 and 840 rpm

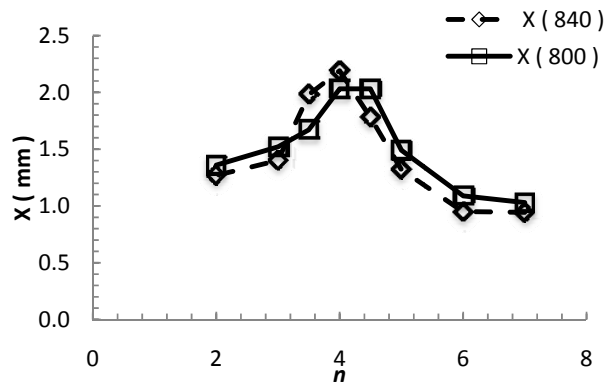

Fig. 5 Experimental response versus number of coils for two different excitation frequencies: 800 and 840 rpm

However, the response pattern is similar in both cases where the maximum responses shifts towards the right (higher  $n$ ) when the excitation frequency is increased from 800 to 840 rpm.

#### IV. CONCLUSION

The concept of adjusting the number of active coils in helical springs is an innovation that can deal with vibration problems from a new perspective. The concept can be further

modified to address vibration control problems in machines, bridges and buildings. Currently, a more accurate model is being developed to study the characteristics of the new concept in a more realistic way. In near future, a feedback control system will be designed to actively control the vibration thorough automatic rotation of the screw inside the spring.

#### ACKNOWLEDGMENT

The authors thank the group of students: Mousa Almosawi, Fahad Alotaibi, Abdulmohsen Alsaqqay and Abdullatif Alnajem, who worked on this project during their capstone design course.

#### REFERENCES

- [1] D. J. Inman, *Engineering Vibrations*. Prentice Hall, 2007.
- [2] B. C. Nakra, "Vibration Control in Machines and Structures Using Viscoelastic Damping", *Journal of Sound and Vibration*, Vol. 211(3), 1998, pp. 449-466.
- [3] C. R. Fuller, S. Elliott, P. A. Nelson, *Active Control of Vibration*. Academic Press, 1997.
- [4] S. Nagarajaiah, S. Ertan, "Structures with Semiactive Variable Stiffness Single/Multiple Tuned Mass Dampers", *Journal of Structural Engineering*, Vol. 133(1), 2007, pp. 67-77.
- [5] T. Kobori, M. Takahashi, T. Nasu, N. Niwa, K. Ogasawara "Seismic Response Controlled Structure with Active Variable Stiffness System", *Earthquake Engineering and Structural Dynamics*, vol. 22, 1993, pp. 925-941.
- [6] J. A. Aardema, *Variable Stiffness Spring Suspension*, US Patent No. 4,832,321, 1989.