

# Piping Fragility Composed of Different Materials by Using OpenSees Software

Woo Young Jung, Min Ho Kwon, Bu Seog Ju

**Abstract**—A failure of the non-structural component can cause significant damages in critical facilities such as nuclear power plants and hospitals. Historically, it was reported that the damage from the leakage of sprinkler systems, resulted in the shutdown of hospitals for several weeks by the 1971 San Fernando and 1994 North Ridge earthquakes. In most cases, water leakages were observed at the cross joints, sprinkler heads, and T-joint connections in piping systems during and after the seismic events. Hence, the primary objective of this study was to understand the seismic performance of T-joint connections and to develop an analytical Finite Element (FE) model for the T-joint systems of 2-inch fire protection piping system in hospitals subjected to seismic ground motions. In order to evaluate the FE models of the piping systems using OpenSees, two types of materials were used: 1) *Steel02* materials and 2) *Pinching4* materials. Results of the current study revealed that the nonlinear moment-rotation FE models for the threaded T-joint reconciled well with the experimental results in both FE material models. However, the system-level fragility determined from multiple nonlinear time history analyses at the threaded T-joint was slightly different. The system-level fragility at the T-joint, determined by *Pinching4* material was more conservative than that of using *Steel02* material in the piping system.

**Keywords**—Fragility, T-joint, Piping, Leakage, Sprinkler.

## I. INTRODUCTION

SINCE the first report on the nonstructural earthquake damage in the 1964 Alaska earthquake, the nonstructural component of the building has influenced greatly on the improvement of the building design codes. In 1971 San Fernando earthquake [1], intensive investigations on the nonstructural component damage had been made. According to Consortium of University for Research in Earthquake Engineering (CUREE) [1], a total installation and construction cost of non-structural elements in any critical facilities account for almost 70% of the total construction cost. In addition to the high construction cost, these nonstructural components, such as Heating-Ventilating-Air Conditioning (HVAC), ceilings, and piping system, were more fragile than structural systems during an earthquake. Therefore, the non-structural component of the building was more susceptible to the damages associated with earthquake. For example, the record showed that about 85% of the total \$7.4 billion damage was attributed to non-structural

systems in 1994 Northridge earthquake [2]. Specifically, the Olive View Hospital had to be shut down shortly after the 1994 Northridge earthquake, due to water damage caused by failure of sprinkler systems [3]. Similarly, during the 1971 San Fernando earthquake, 4 of 11 medical facilities in the area incurred significant economic losses due to the damages on the non-structural components [4].

In recent years, the protection of nonstructural component in occurrence of seismic events has become one of the most important agenda in seismic design area.

Antaki and Guzy [5] conducted static and dynamic tests of the fire protection systems designed in accordance of the National Fire Protection Association (NFPA-13) [6]. The objective of tests was to identify the stiffness, failure modes, and limit states for leakage of 2 inch schedule 40 threaded pipe joints and 2-inch and 4-inch schedule 40 grooved coupling systems that are commonly used in the piping systems.

Ju et al. [7] evaluated the system-level fragility of the piping system connected with a 2-inch threaded T-joint system. The system-level fragility of the complete piping system corresponding to the first leakage was determined from multiple time history analyses using *OpenSees* [8] finite element package.

Ju and Jung [9] developed the seismic fragility of piping system installed in a low-rise building system. This publication focused on the evaluation of seismic fragilities in the multi-branch T-joint piping systems at each floor of RC and steel linear frame buildings. They reported that the probability of the failure at T-joint systems increased as the floor level in the two different buildings increased.

Ju et al. [10] later evaluated the seismic fragility of the piping system connected to a single branch T-joint system subjected to 21 earthquake ground motions. The piping system was installed in 5-, 10-, 15-, and 20-story RC and steel linear frame buildings. The system-level fragilities of the piping system on top floor of the building systems were conducted by a Monte-Carlo simulation accounting for uncertainties in demand.

Therefore, many researchers have recognized a need to address this probabilistic seismic assessment to mitigate risk and to achieve reliable design of the nonstructural components. This paper presented the seismic performance of T-joint connections and development of an analytical Finite Element (FE) model for the T-joint systems of 2-inch fire protection piping system in hospitals subjected to seismic ground motions. In order to evaluate the FE models of the piping systems using an *OpenSees*, the two types of material types was used: 1) *Steel02* material and 2) *Pinching4* material. In particular, the system-level fragility of the piping system using two different

W. Y. Jung is with the Department of Civil Engineering, Gangneung-Wonju National University, Gangneung, Korea.

M. H. Kwon is with the Department of Civil Engineering, GyeongSang National University, JinJu, Korea.

B. S. Ju is with Department of Civil Engineering, North Carolina State University, Raleigh, NC, USA (corresponding author to provide e-mail: bju2@ncsu.edu).

materials for the T-joint connection in *OpenSees* was illustrated in this paper.

II. EXPERIMENTAL AND ANALYTICAL T-JOINT PIPING SYSTEM

University at Buffalo, State University of New York (UB) [11], [12] conducted the various T-joint systems such as 0.75-in, 1-in, and 2-inch. The experimental tests (monotonic and cyclic) were conducted on two materials: 1) Black Iron Schedule 40 and 2) Chlorinated Polyvinyl Chloride (CPVC). The loading rate of monotonic test was 0.01 in/sec and the maximum loading rate of cyclic test was 0.2 in/sec. Fig. 1 showed the test set-up for determining the stiffness of the threaded T-joint system subjected to monotonic and cyclic loading conditions. In addition, the pipe was connected to a water faucet to be capable of capturing the fist leakage point [11], [12].

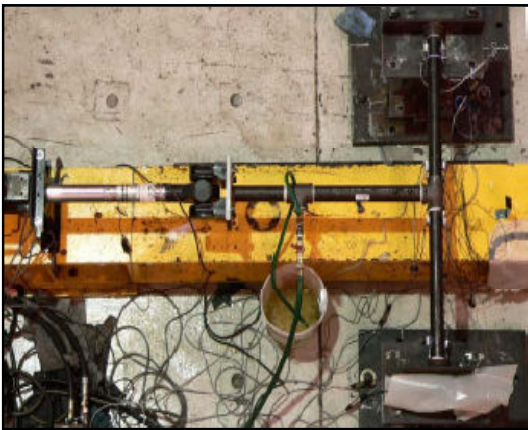

Fig. 1 Threaded T-joint test setup conducted by UB [11]

In order to represent T-joint connection in the piping system, the Finite Element (FE) model was created in Open System for Earthquake Engineering Simulation (*OpenSees*) using two nonlinear rotational springs. This design was based on the experimental results under cyclic loading protocol. The FE model for the T-joint system was shown in Fig. 2. The FE model was also support by a hinge system at the end to allow small rotations.

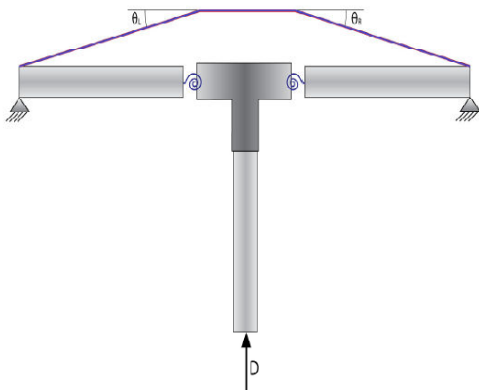

Fig. 2 FE modeling of T-joint system: 2-in pipe

In order to validate the FE model, different material types (*Pinching4* and *Steel02*) were used in this study. First, the *Pinching4* material from the *OpenSees* platform was capable of modeling the hysteretic behavior of the threaded T-joint connection characterized by *Pinched* moment-rotation envelop points (Positive 4 points and Negative 4 points), as shown in Fig. 3. Furthermore, the cyclic degradation of strength and stiffness in both unloading and reloading was determined by *pinching4* material [13].

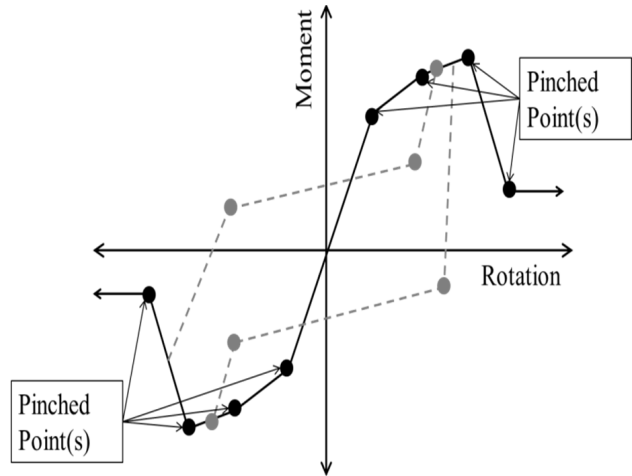

Fig. 3 *Pinching4* material in *OpenSees* [13]

Second, to evaluate hysteretic behavior of the T-joint system, the *Steel02* material in *OpenSees* was used (Fig. 4).

The *Steel02* material can be modeled with yield strength, initial elastic tangent, strain-hardening ratio, and isotropic hardening parameters [13].

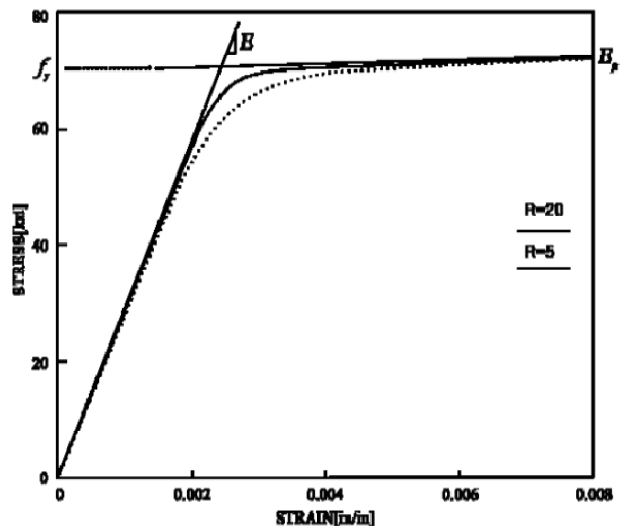

Fig. 4 *Steel02* material in *OpenSees* [13]

A comparison of the moment-rotation relationship of the left spring between the analytical FE models based on two different materials with experimental test under the cyclic loading were

found in Figs. 5 and 6. In addition, the first leak was detected in cyclic tests at rotations of 0.014 to 0.017 radians as suspected from experimental tests. As can be seen in Figs. 5 and 6, the relationship characterized by *steel02* material was in good agreement with the experimental results prior to the failure (i.e. the first leakage point). However, the nonlinear moment-rotation of *Pinching4* material reconciled well with the experimental results till after the failure of the T-joint connection.

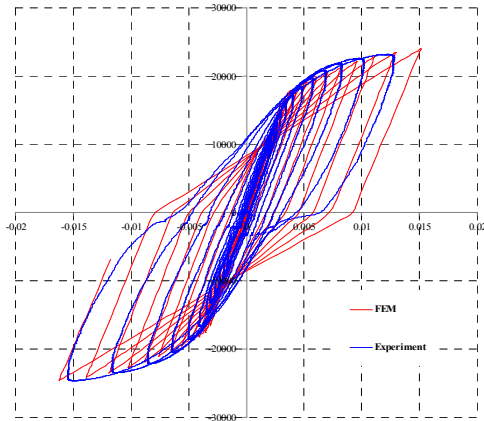

Fig. 5 Validation of T-joint system using Steel02 material

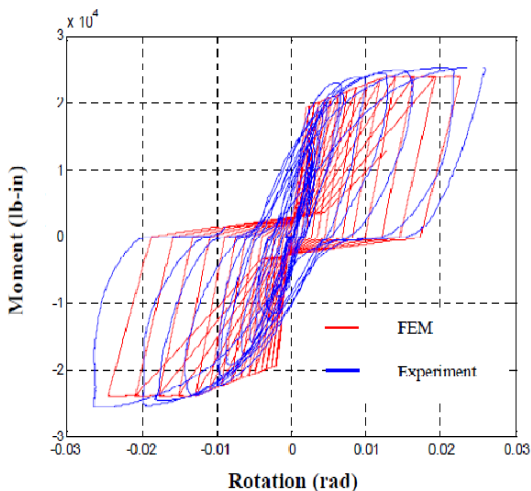

Fig. 6 Validation of T-joint system using pinching4 material

### III. DEFINITION OF SEISMIC FRAGILITY OF PIPING SYSTEM

The seismic fragility and definition of limit state of the piping system was determined by Ju et al. [7]. Seismic fragility for the nonstructural components was the function that relates the probability, such that a nonstructural component would exceed a certain level of damage as a function of the Engineering Demand Parameter (EDP) [14]. The expression for fragility at a Peak Ground Acceleration (PGA) level was defined by (1).

$$P_f(\lambda) = P[\theta \geq \theta_{lim} | PGA = \lambda] \quad (1)$$

The structural fragility given in (2) was usually estimated empirically by conducting multiple nonlinear time history analyses of the structure for various ground motions.

$$P_f(\lambda) = \frac{\sum_{i=1}^N 1(\theta_{i,\lambda} \geq \theta_{lim} | PGA = \lambda)}{N} \quad (2)$$

where,  $\theta_{i,\lambda}$  was the maximum rotation from  $i^{\text{th}}$  earthquake time history analysis at a PGA level of  $\lambda$  and  $1(\cdot)$  is the indicator function.

In order to evaluate the system-level fragility, Ju et al. [7] characterized the limit state criteria corresponding to the first leakage points under cyclic loading. The limit state for the 2-inch Black Iron T-joint piping system was defined by Twice the Elastic Slope (TES) based on ASME Section III BPVP code [15]. As shown in Fig. 7, the rotations corresponding to the first leakage points during three cyclic tests were plotted along with the moment-rotation relationship from the experiment. It can be noted that all the 3 failure rotations lie between the line  $\varphi = 2\theta$  and  $\varphi = 2.5\theta$ . Therefore, the limit state of the T-joint connection was defined by 0.0135 radians as a minor damage.

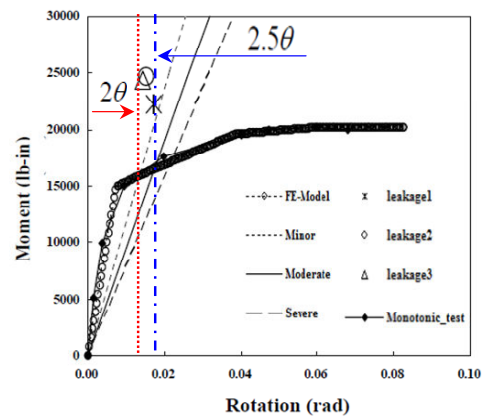

Fig. 7 The limit state of 2-inch black iron T-joint piping system

### IV. PIPING FRAGILITY EVALUATION

Evaluation of the fragility at the 2-inch Black Iron threaded T-joint piping system using two different materials in *OpenSees* was conducted. The full scale piping system on top floor (Fig. 8) was selected from a hospital building. The piping system was supported by hangers, transverse/longitudinal bracing systems, and anchors were located at the end of each side. Furthermore, the main piping system was connected with a T-joint branch piping system at the critical location determined as the point of maximum displacements and rotations from linear time history analyses. In this study, in order to evaluate the system-level fragility, 75 real earthquakes normalized to the same PGA [16] were selected in consideration to the ground motion uncertainty. The fundamental mode frequency conducted by eigenvalue analysis was 1.82 Hz.

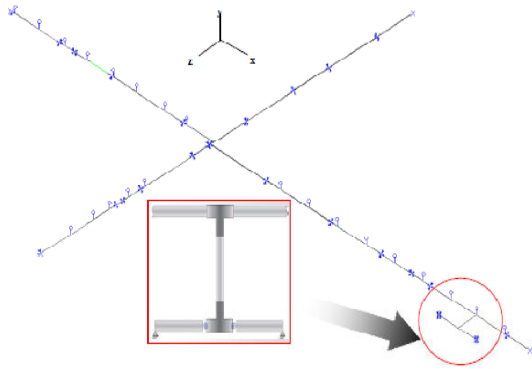

Fig. 8 Piping system with a T-joint branch system

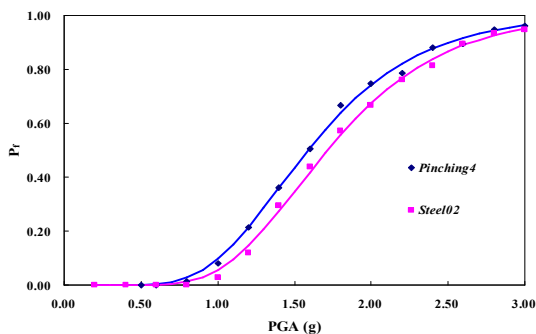

Fig. 9 Piping fragility using different materials in OpenSees

Fig. 9 illustrated the seismic fragility based on log-normal distribution at the T-joint system corresponding to the first leakage damage state (0.0135 rad). The nonlinear time history analyses were conducted at different PGA levels from 0.5g to 3.0g at an interval of 0.2g. As shown in Fig. 9, the piping fragility at the T-joint between the *Pinching4* and *Steel02* materials in *OpenSees* was slightly different. In addition, the maximum difference from the probability of failure at the T-joint connection was 8.99% at PGA level (1.5g). In another word, it revealed that the fragility using *Pinching4* material was more conservative than the piping fragility using *Steel02* material (i.e., predicts the system to be more fragile). Furthermore, the median peak ground acceleration capacity, 50 % probability of failure for *Pinching4* and *Steel02* material at the T-joint system was 1.6g and 1.7g, respectively. The primary reason for the differences in the two different models was concluded that there could be existed energy dissipation and strength degradation under unloading and reloading.

## V. CONCLUSIONS

In this paper, we presented the seismic fragility of piping system at the T-joint connection subjected to 75 earthquake ground motions to account for the function of uncertainty such as fault mechanism, soil types, and frequency. The particular focus was to evaluate the fragility of the piping system using two different models (*Pinching4* and *Steel02*) in *OpenSees*. The conclusions of current study were as followings:

1) The numerical FE models in both cases reconciled well with the experimental test results. Besides, the *Pinching4*

FE model was capable of capturing the post-failure behavior of the T-joint connection.

- 2) The piping fragility subjected to 75 different earthquake set normalized to the same PGA level was slightly different between the *Pinching4* and *Steel02* material in *OpenSees*.
- 3) Furthermore, More experimental with varying diameters and materials should be conducted, in order to mitigate the risk and to achieve a reliable design of the piping system.

## ACKNOWLEDGMENT

This Research was supported by a grant (13SCIPA01) from Smart Civil Infrastructure Research Program funded by Ministry of Land, Infrastructure and Transport (MOLIT) of Korea government and Korea Agency for Infrastructure Technology Advancement (KAIA).

## REFERENCES

- [1] R. Reitherman, "Nonstructural Earthquake Damage," Construction of University for Research in Earthquake Engineering (CUREE), 2009, [http://www.curee.org/image\\_gallery/calendar/essays/2010-CUREE\\_exce rpt.pdf](http://www.curee.org/image_gallery/calendar/essays/2010-CUREE_exce rpt.pdf)
- [2] C. A. Kircher, "It Makes Dollars and Sense to Improve Nonstructural System Performance," Proceedings of Seminar on Seismic Design, Performance, and Retrofit of Nonstructural Components in Critical Facilities, ATC-29-2, 2003
- [3] J. M. Ayres and R. J. Phillips, "Water Damage in Hospital Resulting from the Northridge Earthquake," ASHRAE Transactions Part 1B, SF-98-14-2, 1286-1296, 1998
- [4] R. J. Wasilewski, "Seismic Restraints for piping System," ASHRAE Transactions Part 1B, SF-98-14-1, 1273-1285, 1998
- [5] NFPA-13, Standard for the installation of Sprinkler System, National Fire Protection Association, MA, 2007 Edition
- [6] G. Antaki and D. Guzy, "Seismic Testing of Grooved and Threaded Fire Protection Joints and Correlation with NFPA Seismic Design Provisions," ASME 1998, PVP-Vol. 364, Seismic Engineering-1998, 69-75
- [7] B.S. Ju, S.T. Taninada and A. Gupta, "Fragility Analysis of Threaded T-joint Connections in Hospital Piping Systems," Proceeding of the ASME 2011 Pressure Vessel and Piping Division Conference, Baltimore, Maryland, 2011
- [8] OpenSees, Open System for Earthquake Engineering Simulation, Available at <http://opensees.berkeley.edu>, 2011
- [9] B.S. Ju and W.Y. Jung, "Seismic Fragility Evaluation of Multi-Branch Piping Systems Installed in Critical Low-Rise Buildings," Disaster Advances, Vol. 6(4), 59-65, 2013
- [10] B.S. Ju, W.Y. Jung and Y.H., Ryu, "Seismic Fragility Evaluation of Piping System Installed in Critical Structures," Structural Engineering and Mechanics, An International Journal, Vol. 46, No. 3, 337-352, 2013
- [11] J. Dow, "Testing and Analysis of Iron and Plastic T-joint in Sprinkler Systems, NEESR-GC: Simulation of the Seismic Performance of Nonstructural Systems," Available at [http://nees.org/site/oldnees/ filedir\\_2/REU2009\\_DOW\\_Paper.pdf](http://nees.org/site/oldnees/ filedir_2/REU2009_DOW_Paper.pdf), 2010
- [12] Y. Tian et al., "NEESR Nonstructural : Progress Report on Tests of Tee Joint Component of Sprinkler Piping System," Progress Report, NEESR-GC: Simulation of the Seismic Performance of Nonstructural Systems, October, 2010
- [13] S. Mazzoni et al., OpenSees Command Language Manual, Available at <http://opensees.berkeley.edu>, 2006
- [14] R. Bachman et al., "Engineering Demand Parameters for Nonstructural Components," ATC-58 Project Task Report, ATC, Redwood City, California, 2004
- [15] ASME, Rule for Construction of Nuclear Facility Components, ASME Boiler and Pressure Vessel Code, Section III, American Society of Mechanical Engineers (2004)
- [16] A. Gupta and B. Choi, "Consideration of Uncertainties in Seismic Analysis of Coupled Building Piping System," Nuclear Engineering and Design, 235, 2071-2086, 2005.