

Selection of an Optimum Configuration of Solar PV Array under Partial Shaded Condition Using Particle Swarm Optimization

R. Ramaprabha

I. INTRODUCTION

Abstract—This paper presents an extraction of maximum energy from Solar Photovoltaic Array (SPVA) under partial shaded conditions by optimum selection of array size using Particle Swarm Optimization (PSO) technique. In this paper a detailed study on the output reduction of different SPVA configurations under partial shaded conditions have been carried out. A generalized MATLAB M-code based software model has been used for any required array size, configuration, shading patterns and number of bypass diodes. Comparative study has been carried out on different configurations by testing several shading scenarios. While the number of shading patterns and the rate of change are very low for stationary SPVA but these may be quite large for SPVA mounted on a mobile platforms. This paper presents the suitability of PSO technique to select optimum configuration for mobile arrays by calculating the global peak (GP) of different configurations and to transfer maximum power to the load.

Keywords—Global peak, Mobile PV arrays, Partial shading, optimization, PSO.

NOMENCLATURE

I_{PV}	- Solar module output current (A)
V_{PV}	- Solar module output voltage (V)
I_{ph}	- Photo current of the SPV module (A)
I_r	- Diode reverse saturation current in the equivalent circuit (μA)
R_{se}	- Series resistance in the equivalent circuit of the module(m Ω)
R_{sh}	- Parallel resistance in the equivalent circuit of the module(Ω)
n	- Diode ideality factor
q	- Electron charge ($=1.602 \times 10^{-19}$ C)
k	- Boltzman's constant ($=1.381 \times 10^{-23}$ J/K)
T	- Temperature (Kelvin)
V_t	- Thermal voltage ($=nkT/q$)
G	- Irradiance level (at reference condition $G=1000$ W/m 2)
α	- Short circuit current temperature co-efficient
β	- Open circuit voltage temperature co-efficient
I_{sc}	- Short circuit current of the module
V_{oc}	- open circuit voltage of the module respectively
V_m	- Maximum power point voltage
I_m	- Maximum power point current
P_m	- Maximum power
ref	- Additions subscripts indicate the parameters at reference conditions

SOLAR Photovoltaic array is formed by connecting number of solar photovoltaic (SPV) modules in different configurations to get a desired voltage and current levels. The major problem in a larger SPVA/ building integrated PV (BIPV) arrays/ mobile SPV arrays is the reception of non-uniform insolation/ partial shade. In these cases, the occurrence of partial shading is frequent due to tree leaves falling over it, birds or bird litters on the array, shade of a neighboring construction etc. As each SPV module consists of number of series connected cells, all the cells are forced to carry the same current, even though a few cells under shade produce less photon current. The shaded cells may get reverse biased, acting as loads, draining power from fully illuminated cells. If the system is not properly protected, hot-spot problem [1] can arise and in several cases, the system can be permanently damaged. In conventional SPV systems, this problem reduces the overall power generation to a larger level. Hence the SPVA installation cost is increased, because the number of SPV modules must be increased, and as a result, SPV power generation will be less attractive. This makes the study of partial shading of SPV modules a key issue. The Voltage-Power characteristics of SPV module vary with solar insolation and temperature. Researchers have analog and mathematical models of SPV cells for varying environmental conditions [2], [3]. The difference between all models is the number of necessary parameters used in the computational. There are several equations presented in literature to simulate the behavior of SPV cells. Typical SPV module consists of 36 solar cells connected in series. SPV modules are tied together in different fashion to form an array with required voltage and current levels. The output power of a SPVA decreases considerably, when voltage-current curves of solar cells are not identical due to soiling, temperature variations, cell damaging and partial shading etc. [4]-[6]. In recent years, the impact of partial shadowing on the energy yield of SPV systems has been widely discussed [6]-[9]. Before trying to eliminate or reduce mismatch effects, a detailed understanding of their performance is required. Hence it is convenient to carry out the simulation study with the help of a computer model which properly allows the inclusion of mismatch effects with high accuracy. In most of the studies [10]-[14], the effect of partial shading in reducing the output power of the SPVA has been discussed. But little attention has been paid to the power dissipated by the shaded cells affecting the

R. Ramaprabha is Associate Professor at the Department of EEE, SSN College of Engineering, Rajiv Gandhi Road (OMR), Kalavakkam- 603 110, Chennai, Tamilnadu, India (e-mail: ramaprabhasuresh@gmail.com).

array life and utilization of the array for the worst shaded case. The harmful effects in basic configurations and their comparison have been discussed by [14]. Common use of bypass diodes in antiparallel with the series-connected PV modules can partially improve the power reduction due to partial shadow. In such cases a more complicated Maximum Power Point Tracking (MPPT) algorithms capable to disregard local power maxima is required. Alternatively, the maximum available DC power can be improved if the connection of the SPV modules can be reconfigured such that panels with similar operating conditions are connected in the same series string. Furthermore the parallel configuration should be dominant under partial shaded conditions [14], [15]. However, high output current at low voltage in parallel configuration will have to be properly conditioned to the required level by using suitable DC-DC converter. For the configuration types, the generalized MATLAB programs have been developed which are capable of simulating any number of modules connected in series or parallel and any type of shading patterns. The comparison study is made among the configurations with bypass diodes. For particular insolation and temperature different configurations will be dominant. It is customary to select a proper size of SPV array [16], [17]. Otherwise, a large change in SPV power because of insolation variation caused by shading may lead to instability. Tracking the maximum power point is required in order to extract the largest amount of power from a SPVA, regardless of weather or load conditions. Various MPPT methods have been proposed and used to extract maximum power from SPVA under varying atmospheric conditions and partial shaded conditions [18]-[26].

This paper presents the reconfiguration of SPVA and implementation of MPP tracking of a partially shaded SPVA using PSO. The PSO [27]-[30] algorithm is one of the modern evolutionary algorithms. This algorithm was first proposed by [27]. PSO is a population-based search algorithm characterized as conceptually simple, easy to implement and computationally efficient. The authors aim to realize a power tracking scheme that can find the GP to maximize the generated power from the SPV source. It should be applicable to large scale SPV system, resulting from different combination of solar modules. The proposed PSO scheme is also used to select the optimum configuration under partial shaded conditions. Both functions that are reconfigurations as well GP tracking can be possible using PSO by considering its capability to handle parallel processing.

II. CHARACTERISTICS OF SPVA UNDER PARTIAL SHADED CONDITIONS

The commonly used electrical equivalent circuit for SPV module is shown in Fig. 1 [17], [31]. The relationship between solar cell's current and voltage has both the implicit and nonlinear mathematical equations. Therefore, determination of the equivalent circuit parameters requires more computational effort for each operating condition when electrical performance is analyzed [32]-[35]. In most studies, only the photo-current and the diode saturation current are changed

with irradiation and temperature, respectively, and the other parameters are determined by taking a reference operating condition [1], [8], [31], [34]. However, all of the circuit parameters depend on both irradiation and cell temperature and the relationship between them is nonlinear and cannot be easily expressed by an analytical equation [3], [35]-[39]. In addition, some differences can be seen in the equations that describe the relationship between the parameters and operational conditions [3], [37]. Consequently, every assumption forces the model to fall into error. For this reason an assumption should be done carefully, especially in simulation studies of SPV arrays under mismatch conditions and low irradiated PV modules [40]. Sharma et al. [39] showed that consideration of identical series and parallel resistances for illuminated and dark region of a PV module is not a valid assumption and enhancement of the resistances must be considered in the analysis of partially shaded PV array. Dyk and Meyer [5] also showed that the effects of parallel and series resistances on the PV module performance are significant. In this study, the dependence of all circuit parameters on module temperature and irradiance is included by improved model equations [17], [25], [41]. The effect of varying shunt resistance has been included by fitting a curve obtained from experimental results [26]. The model equations presented in [17] by authors are used for modeling the SPV system. As the importance of bypass diodes is well known, a bypass diode has been included as a part of every module in the M-file code. This section considers that each module is connected with a bypass diode. To include the effect of bypass diode, negative voltages caused by shading is taken as diode forward drop ($\sim 0.7V$) in m-file coding. The equations are for single SPV module.

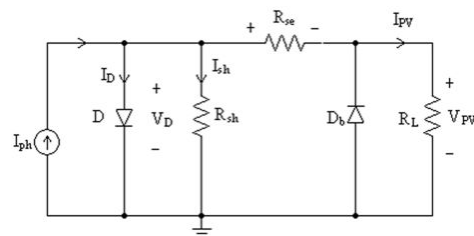

Fig. 1 Equivalent circuit model of a SPVA with bypass diode

After improving the accuracy of equivalent circuit of SPV module model for all operating conditions, the performance of different interconnected SPV arrays are investigated by including bypass diode under different mismatch conditions. The model is developed using MATLAB M-file. The detailed explanation of the effect of bypass diodes in the characteristics is given in [14], [42]. Fig. 2 shows the electrical characteristics of SPVA with bypass diodes under different partial shaded conditions [43]. Number of peaks in the V-P characteristics is less than or equal to the number of zones receiving different insolation.

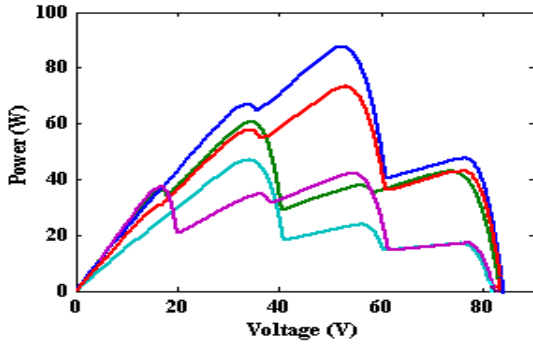

Fig. 2 Characteristics of four series connected SPV modules under partial shaded conditions

From Fig. 2, it is observed that the V-P characteristics have multiple peaks due to partial shading. Among the multiple peaks one is global peak (GP) and others are local peak power points. In this situation the conventional MPPT algorithm could fail to determine the actual GP or even traps into one of the local peaks. Therefore, considerable amount of possible SPV power is not utilized.

III. OVERVIEW OF PARTICLE SWARM OPTIMIZATION

Recently, a number of heuristic optimization techniques such as genetic algorithms (GA), ant colony algorithm (ACO), PSO and recently biogeography-based optimization (BBO), are developed to solve a variety of complex engineering problems that are difficult to be solved using conventional optimization methods. PSO is developed by Kennedy and Eberhart [27]. It was found to be reliable in solving non-linear problems with multiple optima. In PSO, a number of particles form a “swarm” that evolve or fly throughout the feasible hyperspace to search for fruitful regions in which optimal solution may exist. Each particle has two vectors associated with it, the position (X_i) and velocity (V_i) vectors. In N-dimensional search space, $X_i = [x_{i1}, x_{i2}, \dots, x_{iN}]$ and $V_i = [v_{i1}, v_{i2}, \dots, v_{iN}]$ are the two vectors associated with each particle i . During their search, members of the swarm interact with each others in a certain way to optimize their search experience. There are different variants of particle swarm paradigms but the most commonly used one is the gbest model where the whole population is considered as a single neighborhood throughout the flying experience [27], [28]. In each iteration, particle with the best solution shares its position coordinates (gbest) information with the rest of the swarm. Each particle updates its coordinates based on its own best search experience (pbest) and gbest according to the following equations:

$$v_i^{k+1} = wv_i^k + c_1 \text{rand}_1 (pbest_i^k - x_i^k) + c_2 \text{rand}_2 (gbest_i^k - x_i^k) \quad (1)$$

$$x_i^{k+1} = x_i^k + v_i^{k+1} \quad (2)$$

where c_1 and c_2 are two positive acceleration constants, they keep balance between the particle's individual and social

behavior when they are set equal; rand_1 and rand_2 are two randomly generated numbers with a range of $[0, 1]$ added in the model to introduce stochastic nature in particle's movement; and w is the inertia weight and it keeps a balance between exploration and exploitation. In our case, it is a linearly decreasing function of the iteration index:

$$w(k) = w_{\max} - \left(\frac{w_{\max} - w_{\min}}{\text{iter}_{\max}} \right) \times \text{iter} \quad (3)$$

where iter_{\max} is the maximum number of iteration, iter is the current iteration number, w_{\max} is the initial weight and w_{\min} is the final weight. In conclusion, an initial value of w around 1, with a gradual decline toward 0 is considered as a proper choice. The most important factor that governs the PSO performance in its search for optimal solution is to maintain a balance between exploration and exploitation. Recently, PSO developments and applications have been widely explored in engineering and science mainly due to its distinct favorable characteristics [30]. Just like in the case of other evolutionary algorithms, PSO has many key features that attracted many researchers to employ it in different applications in which conventional optimization algorithms might fail [43].

IV. APPLICATION OF PSO TO GP TRACKING OF SPVA

Nonlinear optimization problem can be stated in mathematical terms as follows:

Find $X = (x_1, x_2, \dots, x_n)$ such that $F(X)$ is minimum or maximum

Subject to $g_j(X) \geq 0, j = 1, 2, \dots, m$ and $x_{li} \leq x_i \leq x_{ui}, i = 1, 2, \dots, n$,

where F is the objective function to be minimized or maximized, x_i 's are variables, g_j is constraint function, x_{li} and x_{ui} are the lower and upper bounds on the variables.

In this work the objective function considered is

$F(X) = \text{Maximization of SPVA power, } P_{PV}$

The variable $x_1 = \text{SPVA current, } I_{PV}$

The constraint is $I_{PV_{\max}} \geq I_{PV} \geq I_{PV_{\min}}$.

Here, $I_{PV_{\max}} = I_{sc}$, short circuit current of SPVA and $I_{PV_{\min}} = 0$.

In this work, the PSO is used to find SPVA current which ensure that the function $F(X)$ has a maximum value. The procedure to get the optimum power of SPVA under partial shaded condition is given below:

1. Read number of modules connected, insolation pattern and temperature for each module
2. Initialize PSO parameters such as w_{\max} , w_{\min} , c_1 , c_2 and Iter_{\max}
3. Generate initial population of N particles (design variables) with random positions and velocities;
4. Compute objective value, current and power
5. Measure the fitness of each particle
6. *Update personal best*: Compare the fitness value of each particle with its pbests. If the current value is better than pbest, then set pbest value to the current value;

7. *Update global best*: Compare the fitness value of each particle with gbest. If the current value is better than gbest, set gbest to the current particle's value;
8. *Update velocities*: Calculate velocities V^{k+1} using (1)
9. *Update positions*: Calculate positions X^{k+1} using (2)
10. Return to step 4 till the current iteration reaches the maximum iteration number;
11. Output the optimal value of SPVA current and corresponding SPVA power in the last iteration.

The code for PSO has been written in MATLAB and the simulation results are presented for five set of different shading patterns for SPVA (Fig. 3). The performance of the PSO is validated graphically by comparing its output (marked in green color) with that of the binary search method (marked in red color). In all the cases, PSO gives the optimum power (global peak) which is matched with the result of binary search.

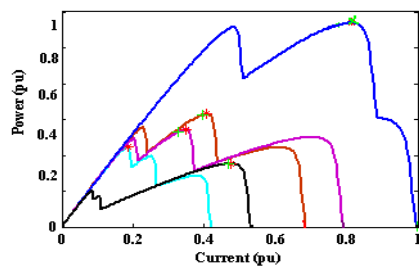

Fig. 3 Validation of PSO for GP tracking of partial shaded SPVA

V. SIMULATION OF DIFFERENT SPVA CONFIGURATIONS AND THEIR PERFORMANCE COMPARISON

Practically partial shade has great impact on larger arrays. For understanding the practical cases, it is required to go for larger arrays with different configurations. Several SPVA configurations have been proposed in the literature as shown in Fig. 4. [1], [8], [15]-[17]. They are series, parallel, series-parallel (SP) total cross tied (TCT) and bridge linked (BL) configurations. Series and parallel configurations are the basic configurations and the performance of these configurations has been discussed in detail by [14]. The major drawbacks of using the series or parallel configuration are that the current and voltage is less respectively. The other derived configurations are shown from Figs. 4 c to f [17]. The importance of selecting the proper size of the PV array and batteries in partially shade SPV systems has been discussed by [44]. It is required for the stable operation of SPV system with a sudden and large change in SPV power because of insolation variation, caused by shading etc. Shading caused due to passing clouds also has a financial claim on the utility. Jewell and Unruh [45] have carried out an economic analysis to estimate the cost of the fluctuations in power generation from a PV source. Based on the literature it is understood that not only the size of the SPVA but also its configuration that significantly affects its power output, and therefore, the performance of the system under partially shaded conditions.

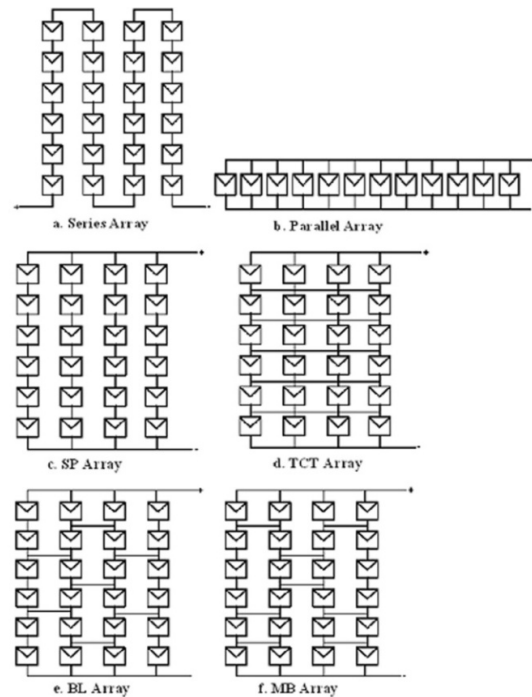

Fig. 4 Schematic diagram of SPVA configurations

From the above discussion, it may be concluded that, while it is very important to model, study, and understand the effects of shading on SPV arrays, a simple tool is not available for the purpose. Therefore, it is felt that there is a need for a flexible, interactive, and comprehensive simulation model capable to predict the PV characteristics (including multiple peaks) and output power under partially shaded conditions. The improved model [17] developed by authors have been taken for the analysis. Modeling of a large array with shading patterns is very complex. In this work, a generalized code has been developed for all the configurations with and without considering the effect of changing R_{sh} . This program gives the output power, voltage and current values for any irradiance and temperature patterns. The architecture of the developed software [17] is shown in Fig. 5.

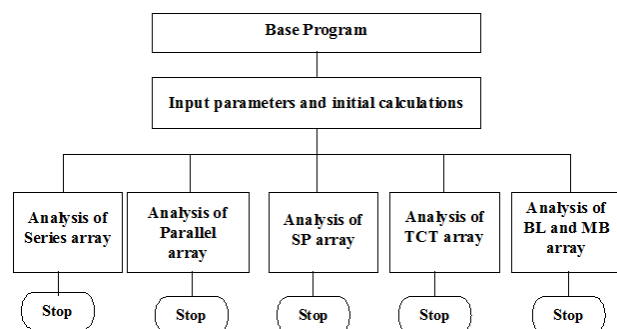

Fig. 5 Architecture of the developed software

VI. RMSD OF DIFFERENT SPVA CONFIGURATIONS UNDER DIFFERENT SHADING SCENARIOS

In this section a comparison is made amongst the SPVA configurations of different array sizes in terms of Root mean square deviation (RMSD) and mean value of both voltage and power. The RMSD has been calculated using (1):

$$\text{RMSD} = \sqrt{\frac{\sum_{i=1}^n (P_{\max(\text{unshaded})} - P_{\max(\text{shaded})})^2}{n}} \quad (4)$$

Here the case where one bypass diode across group of 36 cells (one module) has been considered. The array sizes are: 2x6, 6x2, 2x4, 4x2, 3x4, 4x3, 4X6, 6x4, 3x3 and 4x4. Fifteen different random shading profiles are generated for each of the ten different array sizes. The power, voltage and current value of each configuration is obtained for each of these shading patterns. The mean value of power and voltage is calculated for each configuration for each size. The mean value denotes the mean power and voltage which can be obtained from any configuration. Similarly RMSD is calculated for each configuration by primarily subtracting the uniform irradiance value from the partial shaded value. These values are squared and then the square root of its average is obtained. This gives the RMSD value for a configuration of a particular size. Table I gives the mean value and RMSD value for all the configurations with different sizes. From Table I it can be inferred that depending on the size of array and type of shading scenario different configurations are dominant. But in most of the cases TCT seems to be dominant closely followed by MB. It is also note that wherever the modules with same shade are grouped in a string, MB is dominant in which ties are less compared to TCT.

25 different random shading profiles are generated for each array size. The power, voltage and current value of each configuration is obtained for each of these shading patterns. The mean value of power and voltage is calculated for each configuration for each size. The mean value denotes the mean power and voltage which can be obtained from any configuration. Similarly RMSD is calculated for each configuration by primarily subtracting the uniform insolation value from the partial shaded value. These values are squared and then the square root of its average is obtained. This gives the RMSD value for a configuration of a particular size. Table I gives the mean value and RMSD value for all the configurations with different sizes. For different array sizes the comparison of mean and RMSD values of all the configurations are given from Table I.

From Table I it can be inferred that depending on the size of array different configurations are dominant. But in most of the cases TCT seems to be dominant closely followed by MB.

TABLE I
COMPARISON OF RMSD AND MEAN VALUE FOR DIFFERENT CONFIGURATIONS WITH DIFFERENT SIZES

Array Size	Configuration	Maximum Power (W)		Voltage at MPP (V)	
		Mean Value	RMSD Value	Mean Value	RMSD Value
2X4	SP	92.76	172.40	20.29	10.75
2X4	TCT	94.67	170.96	22.92	9.01
2X4	BL	105.58	161.79	24.23	7.94
2X4	MB	121.98	146.44	27.28	4.80
4X2	SP	103.96	162.45	44.35	17.79
4X2	TCT	117.7	149.56	41.59	20.96
4X2	BL	104.00	162.41	44.33	19.40
4X2	MB	114.02	153.46	42.44	19.39
2X6	SP	145.51	252.85	20.38	10.69
2X6	TCT	149.78	249	22.25	9.57
2X6	BL	175.42	223.74	27.39	4.89
2X6	MB	187.23	213.27	27.39	4.87
6X2	SP	143.13	254.32	56.59	31.86
6X2	TCT	160.09	237.43	57.01	32.5
6X2	BL	143.11	254.35	56.58	31.86
6X2	MB	165.34	233.52	65.97	25.05
3X4	SP	128.14	269.75	27.69	30.11
3X4	TCT	142.58	255.72	29.88	28.47
3X4	BL	146.70	251.35	33.43	24.78
3X4	MB	144.93	253.70	35.57	22.87
4X3	SP	125.79	272.99	34.25	11.51
4X3	TCT	132.37	263.53	34.11	23.36
4X3	BL	132.89	263.01	36.41	21.06
4X3	MB	137.95	257.95	40.40	17.07
3X3	SP	85.72	212.85	27.89	16.05
3X3	TCT	92.79	206.06	26.70	17.76
3X3	BL	84.5	214.41	29.21	15.33
3X3	MB	83.22	215.21	28.83	15.46
4X4	SP	145.31	384.64	33.30	26.61
4X4	TCT	164.62	366.41	34.05	25.71
4X4	BL	145.03	384.56	36.51	24.46
4X4	MB	144.14	385.53	40.93	19.65
4X6	SP	186.66	606.83	22.25	35.43
4X6	TCT	211.54	583.56	26.51	30.46
4X6	BL	186.06	606.71	28.69	29.52
4X6	MB	227.06	572.72	39.42	23.4
6X4	SP	197.86	596.88	46.31	42.47
6X4	TCT	234.57	561.86	45.18	42.41
6X4	BL	184.48	607.33	48.79	40.98
6X4	MB	219.1	579.74	54.58	37.99

VII. PRACTICAL VERIFICATION

To verify the outputs obtained from software simulation, practical verification are performed. 3X3 SPVA (SOLKAR solar module) setup is used. The specifications are given in appendix. The terminals from this setup are drawn to the panel board. This is shown in Fig. 6 along with the electronic load to trace the characteristics. The electronic load [14] is used to verify the characteristics. A sample snap shot of the CRO screen shows V-I characteristics of the different SPVA configurations for a particular shading pattern (Fig. 10). GWINSTEK GDS-1022 Digital Storage Oscilloscope (DSO) is used to trace the practical characteristics. It is calibrated

using Fluke5500A Multi-Product Calibrator. For different insolation and temperature the practical characteristics are easily traced out using electronic load method and the relevant data traced by DSO are stored in Excel spreadsheet to calculate V-P characteristics and for comparison of model parameters.

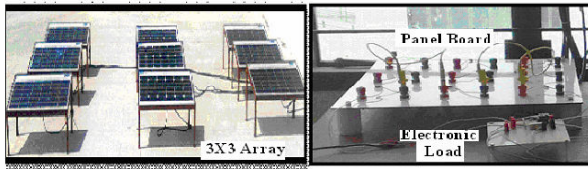

Fig. 6 Practical setup of a 3X3 array with Panel board and Electronic load

Outputs were verified for uniform as well as partial shaded conditions. Artificial shadings were created. Multiple peaks were observed on introduction of bypass diodes. Also value of power obtained increased considerably by inclusion of bypass diodes. The practical verification was done for several input shading patterns. The outputs obtained were closer to the outputs obtained from simulation which took into consideration the effect of varying R_{sh} .

VIII. OPTIMUM SELECTION OF SPVA UNDER PARTIAL SHADED CONDITIONS USING PSO

This section deals with a dynamical electrical array reconfiguration of SPVA under partial shaded conditions to improve its energy production. The reconfiguration strategy is carried out by inserting a controllable switch between the SPV modules in an array which allows electrical reconnection of SPV modules [46] depending on the input insolation and temperature conditions. As a result, the SPV system exhibits a self-capacity for real time adaptation to the SPV generator external operating conditions in order to improve the energy extraction of the system. SP configuration is the most commonly existing/used SPVA configuration due to its simplicity and low cost per kW_{peak} . As discussed in the previous section, series connection of SPV modules in SP configuration can adversely affect the maximum available power when they are operating at different conditions/partially shaded. Fig. 7 shows a set-up for improving the extraction of energy from SPVA under partial shaded conditions using PSO based array reconfigurable system.

The control signals for the switches to make proper array reconfiguration is based on the output from PSO algorithm. The insolation and temperature data has been fed to the PC using corresponding sensors and data acquisition system. (Dynamab weather tech data logger with sensors) PSO algorithm is used to find out the maximum power in each configuration as well as global best from the output of different array configurations. All the computations have been done using MATLAB software. The corresponding signals have been given to the switch to reconfigure the array. For practical case, LTC201A (quad switch) switcher IC [47] can be used.

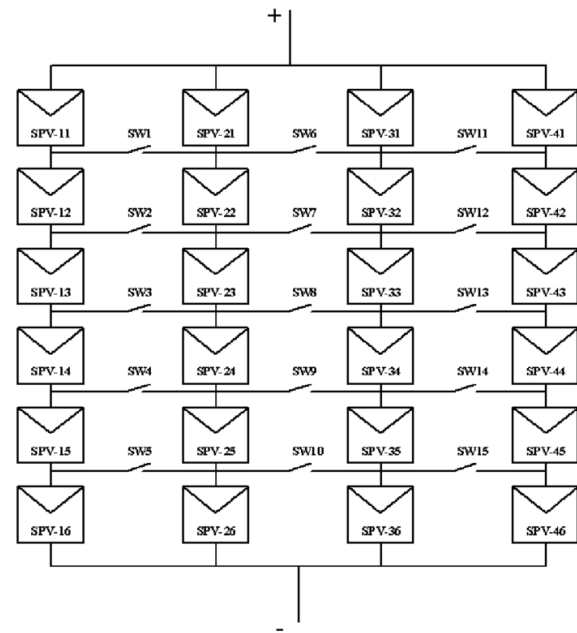

Fig. 7 Schematic of Electrical Reconfiguration of SPVA

Fig. 8 plots the convergence of total power computed by PSO over the number of iterations for different shading patterns [48]. Initially, the particles are randomly initialized. Therefore, the initial power is always high. This initial power corresponds to the 0th iteration. As the algorithm progresses, the convergence is drastic and it finds a global maxima very quickly. The number of iterations needed for the convergence is seen to be 5-10, for this application environment.

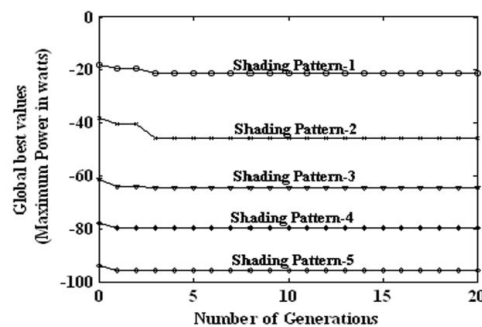

Fig. 8 The trend of convergence of PSO with the number of iterations for different shading patterns

After finding the global peak produced by optimum configuration, corresponding pulses will be given to the analog switch. Fig. 9 shows the pulse pattern produced for different configuration based on the result computed by PSO.

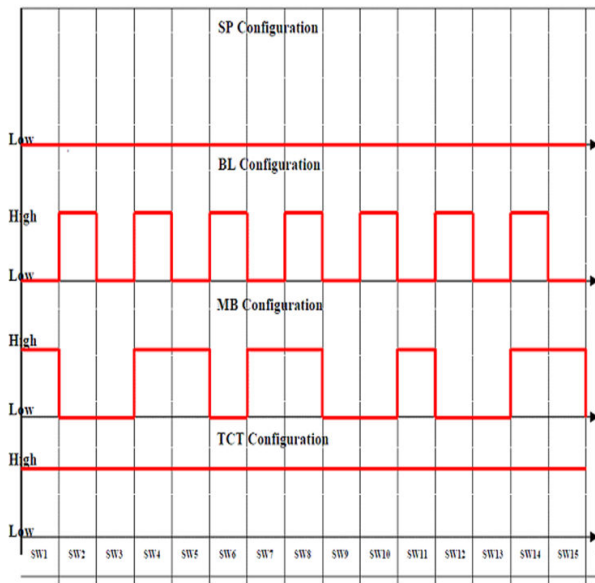

Fig. 9 Pulse pattern given to switches for reconfiguration

After reconfiguring the PSO give the gbest value of the selected configuration which will be the reference GP power value. This reference value is compared with the actual power of SPVA and error signal is processed with PI controller. The output of the controller is then compared with high frequency triangular carrier to produce PWM pulses to chopper to transfer maximum power to the load. The block diagram of the proposed system is shown in Fig. 10

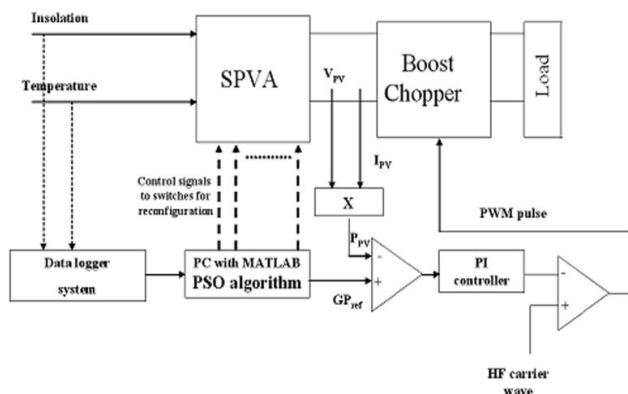

Fig. 10 Block diagram of proposed PSO based system

IX. CONCLUSION

In this paper, PSO technique is used to track the global maximum power point of SPVA that are exposed to unequal solar irradiation which occurs in the real solar power systems. The algorithm is tested for different set of input insolation and temperature patterns. The obtained results prove that the proposed system is able to track efficiently the GP with high accuracy and reliability. Moreover, analysis of various SPVA configurations with respect to environmental parameters by

developing a more realistic model using MATLAB M-file has been presented. From the comparison of different configurations under different random shading patterns, it is found that different configurations are dominant under different shading patterns. To get more energy output from SPVA reconfiguration of SPVA has been implemented using PSO. This reconfiguration method offers a greater output power than the PV systems with static configuration.

APPENDIX

The Parameters of the SOLKAR solar Module used for practical verification at STC (1000 W/m^2 and $T=25^\circ\text{C}$) is given below:

Rated Power (P)	:	37.08W
Voltage at Maximum power (V_m)	:	16.56 V
Current at Maximum power (I_m)	:	2.25 A
Open circuit voltage (V_{oc})	:	21.24 V
Short circuit current (I_{sc})	:	2.55A
No. of Series Cells (N_s)	:	36

ACKNOWLEDGMENT

The author wishes to thank the management of SSN college of Engineering for providing all the experimental and computational facilities to carry out this work.

REFERENCES

- [1] V. Quaschnig and R. Hanitsch, "Numerical simulation of current-voltage characteristics of photovoltaic systems with shaded solar cells", *Solar Energy*, Vol. 56, No. 6, pp. 513-520, 1996.
- [2] M. Wolf and H. Rauschenbach, "Advanced Energy Conversion", No.3, p.455, 1963.
- [3] J. A. Gow and C. D. Manning, "Development of a photovoltaic array model for use in power-electronics simulation studies", *IEEE Proc. Electr. Power Appl.*, Vol. 146, No.2, pp.193-200, 1999.
- [4] H. Kawamura, K. Naka, N. Yonekura, S. Yamanaka, H. Kawamura, H. Ohna, and K. Naito, "Simulation of I-V characteristics of a PV module with shaded PV cells", *Solar Energy Materials and Solar Cells* 75, 613-621, 2003.
- [5] E. E. V. Dyk, E. L. Meyer, F. J. Vorster and A. W. R. Leitch, "Long-term monitoring of photovoltaic devices", *Renewable Energy* 25, 183-197, 2002.
- [6] D. Weinstock and J. Appelbaum, "Shadow Variation on Photovoltaic Collectors in a Solar Field", in the proc. of 23rd IEEE Convention of Electrical and Electronics Engineers, pp. 354-357, 2004.
- [7] A. Woyte, J. Nijs and R. Belmans, "Partial shadowing of photovoltaic arrays with different system configurations: literature review and field test results", *Solar Energy* 74, pp 217-233, 2003.
- [8] N. D. Kaushika and N. K. Gautam, "Energy yield simulations of interconnected solar PV arrays", *IEEE Transactions on Energy Conversion*, Vol. 18, No.1, pp 127-134, 2003.
- [9] A. W. Y. Ho and S. R. Wenham, "Intelligent strategies for minimizing mismatch losses in photovoltaic modules and systems", in the proc. of 17th European Photovoltaic Solar Energy Conference and Exhibition, Munich-Germany, 2001.
- [10] Hans. S. Rauschenbach, "Electrical output of Shadowed Solar Arrays", *IEEE Transactions on Electron Devices*, Vol. 18, No. 8, pp 483-490, 1971.
- [11] M. C. Alonso-García, J. M. Ruiz and W. Herrmann, "Computer simulation of shading effects in photovoltaic arrays", *Renewable Energy*, Vol. 31, No. 12, pp 1986-1993, 2006.

- [12] M. C. Alonso-García, J. M. Ruiz and F. Chenlo, "Experimental study of mismatch and shading effects in the I-V characteristic of a photovoltaic module", *Solar Energy Materials & Solar Cells* 90, pp 329–340, 2006.
- [13] Engin Karatepe, Mutlu Boztepe and Metin Colak., "Development of suitable model for characterizing photovoltaic arrays with shaded solar cells", *Solar Energy*, pp 329-340, 2007.
- [14] R. Ramaprabha and B. L. Mathur, "Effect of Shading on Series and Parallel Connected Solar PV Modules", *Journal of Modern Applied Science*, pp 32-41, 2009.
- [15] C. Gonzalez and R. Weaver, "Circuit design considerations for photovoltaic modules and systems," in *Proc. 14th IEEE Photovolt. Spec. conf.*, pp. 528–535, 1980.
- [16] N. F. Shephard and R. S. Sugimura, "The integration of bypass diode with terrestrial photovoltaic modules and arrays," in *Proc. 17th IEEE Photovolt. Spec. Conf.*, pp. 676, 1984.
- [17] R. Ramaprabha and B. L. Mathur, "A Comprehensive Review and Analysis of Solar Photovoltaic Array Configurations under Partial Shaded Conditions", *International Journal of Photo energy*, Special Issue on Recent Developments in Solar Energy Harvesting and Photo catalysis, Vol. 2012, pp 1-16, Feb 2012.
- [18] N. Kasa, T. Lida and L. Chen, "Flyback inverter controlled by sensorless current MPPT for photovoltaic power system", *IEEE Transactions on Industrial Electronics*, Vol. 52, No.4 , pp 1145–1152, 2005.
- [19] N. Femia, G. Petrone, G. Spagnuolo, and M. Vitelli, "Optimization of perturb and observe maximum power point tracking method", *IEEE Transaction on Power Electronics*, Vol. 20, No. 4, pp 963–973, 2005.
- [20] M. Veerachary, "Power tracking for non-linear PV sources with coupled inductor SEPIC converter", *IEEE Transactions on Aerospace and Electronic Systems* 41 (3), pp 1019–1029, 2005.
- [21] Joung Hu Park, Jun-YounAhn, Bo-HyungCho and Gwon-Jong Yu, "Dual module based maximum power point tracking control of photovoltaic systems", *IEEE Transactions on Industrial Electronics*, Vol. 53, No. 4, pp 1036–1047, 2006
- [22] E. V. Solodovnik, S. Liu and R. A. Dougal, "Power controller design for maximum power point tracking in solar insulations", *IEEE Transactions on Power Electronics*, Vol. 19, No. 5, pp 1295–1304, 2004.
- [23] K. Kobayashi, I. Takano, and Y. Sawada, "A study on a two stage maximum power point tracking control of a photovoltaic system under partially shaded insolation conditions", *Proceedings of the IEEE Power Engineering Society General Meeting*, vol. 4, pp. 2612–2617, 2003.
- [24] A. Kajihara and T. Harakawa, "On considerations of equivalent model about PV cell under partial shading", *Proceedings of Japan Industry Applications Society Conference IEE of Japan*, Vol. 1, No. 71, pp 289–292, 2005.
- [25] Hiren Patel and VivekAgarwal, "MATLAB-Based Modeling to Study the Effects of Partial Shading on PV Array Characteristics", *IEEE Transactions on Energy Conversion*, Vol. 23, No. 1, pp 302-310, 2008.
- [26] R. Ramaprabha, M. Balaji and B. L. Mathur, "Maximum Power Point Tracking Of Partially Shaded Solar PV System Using Modified Fibonacci Search Method With Fuzzy Controller", *International Journal of Electrical Power and Energy Systems*, Elsevier publications, Vol. 43, pp. 754-765, 2012.
- [27] J. Kennedy and R. Eberhart, "Particle swarm optimization", *Proceedings of IEEE International Conference on Neural Networks (ICNN'95)*, Vol. 4, pp.1942–1948, 1995.
- [28] Y. B. Wang, XinPeng and Ben-Zheng Wei, "A new particle swarm optimization based auto tuning of PID controller", *Proceedings of IEEE International Conference on Machine Learning and Cybernetics*, July, pp.1818–1823, 2008.
- [29] R. C. Eberhart and Y. Shi, "Comparing Inertia Weights and Constriction Factors in Particle Swarm Optimization", *Proceedings of the IEEE International Congress Evolutionary Computation*, San Diego, Vol. 1, pp. 84-88, 2000.
- [30] K. T. Chaturvedi, M. Pandit and L.Srivastava, "Particle Swarm Optimization with Time Varying Acceleration Coefficients for Non-Convex Economic Power Dispatch", *Electrical Power and Energy Systems*, Vol. 31, No. 6, pp. 249-257, 2009.
- [31] J. A. Duffie and W. A. Beckman, "Solar Engineering and Thermal Processes", John Wiley & Sons Inc., New York, 1991.
- [32] K. F. Teng and P. Wu, "PV module characterization using Q-R decomposition based on the least square method", *IEEE Transactions on Industrial Electronics*, Vol. 36, No. 1, pp 71–75, 1989.
- [33] K. Araki and M. Yamaguchi, "Novel equivalent circuit model and statistical analysis in parameters identification", *Solar Energy Materials and Solar Cells* 75, pp 457–466, 2003.
- [34] T. Ikegami, T.Maezono, F. Nakanishi, Y. Yamagata K. Ebihara, "Estimation of equivalent circuit parameters of PV module and its application to optimal operation of PV system", *Solar Energy Materials and Solar Cells* 67, pp 389–395, 2001.
- [35] J. Merten, J. M. Asensi, C. Voz, A. V. Shah, R. Platz and J.Andreu, "Improved equivalent circuit and analytical model for amorphous silicon solar cells and modules", *IEEE Transactions on Electron Devices*, Vol.45, No. 2, pp 423–429, 1998.
- [36] M. A. Blas, J. L. Torres, E. Prieto and A. Garcia, "Selecting a suitable model for characterizing photovoltaic devices", *Renewable Energy* 25, pp 371–380, 2002.
- [37] L. Lu and H.X.Yang, "A study on simulations of the power output and practical models for building systems", *Journal of Solar Energy Engineering*, 126, pp 929–935, 2004.
- [38] M. K. El-Adawi and I. A. Al-Nuaim, "A method to determine the solar cells series resistance from a single I-V. Characteristic curve considering its shunt resistance – new approach", *Vacuum* 64, pp 33–36, 2002.
- [39] A. K. Sharma, R. Dwivedi and S. K. Srivastava, "Performance analysis of a solar array under shadow condition", *IEE Proceedings-G* 138 (3), pp 301–306, 1991.
- [40] Engin Karatepe, Mutlu Boztepe and Metin Colak, "Development of suitable model for characterizing photovoltaic arrays with shaded solar cells", *Solar Energy*, pp 329-340, 2007.
- [41] Marcelo Gradella Villalva, Jonas Rafael Gazoli, and Ernesto Ruppert Filho, "Comprehensive Approach to Modeling and Simulation of Photovoltaic Arrays", *IEEE Transactions on Power Electronics*, vol. 24, no. 5, pp 1198-1208, 2009.
- [42] S. Silvestre, A. Boronat and A. Chouder, "Study of bypass diodes configuration on PV modules", *Applied Energy* 86, pp 1632–1640, 2009.
- [43] R.Ramaprabha, N. Balamurugan and B.L.Mathur, "Implementation of Particle Swarm Optimization based Maximum Power Point Tracking of Solar Photovoltaic Array under Non uniform Insolation Conditions", *International Review of Modelling and Simulation*, Vol.6, No.3, pp 1503-1510, 2011.
- [44] Hiren Patel and VivekAgarwal, "Maximum Power Point Tracking Scheme for PV Systems operating under Partially Shaded Conditions," *IEEE Transactions on Industrial Electronics*, Vol. 55, No. 4, pp 1689-1698, 2008.
- [45] W. T. Jewell and T.D. Unruh, "Limits on cloud-induced fluctuation in photovoltaic generation," *IEEE Transactions on Energy Conversion*, vol. 5, no. 1, pp. 8–14, 1990.
- [46] G. Velasco, J. J. Negroni, F. Guinjoan and R. Pique, "Irradiance Equalization Method for Output Power Optimization in Plant Oriented Grid-Connected PV Generators", 11th European Conference on Power Electronics and Applications, (EPE 05). Dresden, September 2005.
- [47] Linear Technology LTC201A Datasheet. Linear Technology Corporation, 1991.
- [48] www.mathworks.com.