

Congestion Management in a Deregulated Power System with Micro Grid

Guguloth Ramesh, T. K. Sunil Kumar

Abstract—This paper presents congestion management in deregulated power systems. In a deregulated environment, every buyer wants to buy power from the cheapest generator available, irrespective of relative geographical location of buyer and seller. As a consequence of this, the transmission corridors evacuating the power of cheaper generators would get overloaded if all such transactions are approved. Congestion management is a mechanism to prioritize the transactions and commit to such a schedule which would not overload the network. The congestions in the transmission lines are determined by Optimal Power Flow (OPF) solution, which is carried by primal liner programming method. Congestion in the transmission lines are alleviated by connected Distributed Generation (DG) of micro grid at load bus. A method to determine the optimal location of DG unit has been suggested based on transmission line relief sensitivity based approach. The effectiveness of proposed method has been demonstrated on modified IEEE-14 and 30 bus test systems.

Keywords—Congestion management, Distribution Generation (DG), Transmission Line Relief (TLR) sensitivity index, OPF.

I. INTRODUCTION

WITH the increase in the level of global warming, renewable based Distributed Generators (DGs) will increasingly play a dominant role in electricity production. Distributed Generation (DG) is any small scale power generation technology that provides electric power at a site closer to customer than central station generation. Distributed generation based on solar energy (photovoltaic and solar thermal), wind, biomass, mini hydro along with use of fuel cells and micro turbines will gain considerable momentum in the near future. A micro grid consists of clusters of load and DGs that operate as a single controllable system [1]. The interconnection of DGs to the utility grid through power electronic converters has raised concern about proper load sharing between different DGs and the grid [2], [3].

The privatization and deregulation of electricity markets has a very large impact on almost all the power systems around the world. Competitive electricity markets are complex systems with many participants who buy and sell electricity. In competitive market, system security plays a vital role from the market/system point of view. Congestion problem occurs most of the case in deregulated power systems [4].

When power producers and consumers of electrical energy desire to produce and consume total in amounts that would cause the transmission system to operate at or beyond one or more transfer limits, the system is said to be congested [5].

Congestion is a technical problem, which occurs in transmission lines due to insufficient transfer capabilities and line outages in the systems, which occur both regulated and deregulated power system but most of the time occurs in deregulated manner due to competition in power producers and consumers [6].

Congestion management is a mechanism to prioritize the transactions and commit to such a schedule which would not overload the network. Despite these measures, congestion can still occur in real time following a forced outage of transmission line. The system operator then handles this situation by means of real time congestion management. Thus, congestion management involves precautionary as well as remedial action on system operator's part [7]. The scope of transmission congestion management in the deregulated environment involves defining a set of rules to ensure control over generators and loads in order to maintain acceptable level of system security and reliability. Congestion in transmission line is relieved by load curtailment, generation rescheduling, built new transmission line, Flexible AC Transmission System (FACTS) devices and Distributed Generation (DG) unit, are different methods of congestion management [8].

In restructured environment, with ever-increasing demand of electricity and increase open access, transmission line congestion is quit frequent. For maximum benefit and mitigation of congestion, proper sizing and location of distribution generation unit are necessary. Paper [9] presents simple methods for optimal sizing and optimal location of DG, which are the cost of installation of DG and congestion index, and transmission line loss and congestion index. Line flow sensitivity for line reactance method is used for to relieve congestion without affecting transaction [10].

Restructuring of power systems have created an increased interest in distributed generation (DG), which is expected to play an increasingly essential role in electric power systems operation and planning. Several benefits result by integrating DG with power system. Most important economic benefits bring about by DG technologies to the power system are modeled and quantified in economic terms in [11]. For reducing the solution space a priority list of candidate buses is formed and then optimal placement and sizing of DG in potential buses is discussed [12]. Power Transfer Distribution Factor (PTDF) and Transmission Line Relief (TLR) sensitivity for relieve congestion in the system by load curtailment have been discussed in [13]. The test systems data's have been taken IEEE 14 and 30 bus systems [14].

This paper is describes congestion management in deregulated power system with Distributed Generation (DG)

Guguloth Ramesh, Research Scholar and Dr. T. K. Sunil Kumar, Assistant Professor are with the National Institute of Technology Calicut, Kerala-673601, India (e-mail: nayakramesh40@yahoo.co.in, tksunil@nitc.ac.in).

unit. The congestion problem in IEEE 14 and 30 Bus systems are determined by primal linear programming based optimal power flow solution. The remedial action is taken by Distribution Generation (DG) unit and the optimal placement of Distribution Generation (DG) unit is found by Transmission Line Relief (TLR) sensitivity index.

This paper is organized as follows: Section II deals with congestion management. Section III presents Distribution Generation unit effects on the test systems. Transmission Line Relief (TLR) sensitivity index is presented in Section IV. Section V presents simulations results at various operating conditions. Finally section VI concludes this paper.

II. CONGESTION MANAGEMENT

The basic principle for the transmission congestion management could be illustrated with the help of the traditional spot pricing theory. In this framework, the central dispatcher optimally dispatches the generators such that the social welfare is maximized while satisfying the operation and security related constraints. Specifically, the dispatcher solves the following optimization problem with primal linear programming method to maximize the social welfare, where changes system controls to enforce liveried constraints while minimize the cost:

$$\min (\sum_{i=1}^{N_G} C_g(P_{g_i}) - \sum_{i=1}^{N_D} B_d(P_{d_i})) \quad (1)$$

Subjected to

$$P_{g_i} - P_{d_i} = \sum_{j=1}^{N_B} |V_i| |V_j| |Y_{ij}| \cos(\delta_i - \delta_j - \theta_{ij}) \quad (2)$$

$$Q_{g_i} - Q_{d_i} = \sum_{j=1}^{N_B} |V_i| |V_j| |Y_{ij}| \sin(\delta_i - \delta_j - \theta_{ij}) \quad (3)$$

$$P_{g_i, \min} \leq P_{g_i} \leq P_{g_i, \max} \quad (4)$$

$$Q_{g_i, \min} \leq Q_{g_i} \leq Q_{g_i, \max} \quad (5)$$

$$P_{d_i, \min} \leq P_{d_i} \leq P_{d_i, \max} \quad (6)$$

$$Q_{d_i, \min} \leq P_{d_i} \leq P_{d_i, \max} \quad (7)$$

$$V_{i, \min} \leq V_i \leq V_{i, \max} \quad (8)$$

$$T_{ij} \geq 0 \quad (9)$$

where, P_{g_i}, Q_{g_i} are real and reactive power generations and P_{d_i}, Q_{d_i} are real and reactive power demand at bus i . $P_{g_i, \min}$, $P_{g_i, \max}$ and $Q_{g_i, \min}, Q_{g_i, \max}$ are real and reactive power minimum and maximum generation limits at bus i . $P_{d_i, \min}$, $P_{d_i, \max}$ and $Q_{d_i, \min}, Q_{d_i, \max}$ are real and reactive power minimum and maximum demand limits at bus i . The objective function $C_{g_i}(P_{g_i})$ is cost function for generating real power P_{g_i} , and $B_{d_i}(P_{d_i})$ is demand function at bus i . The bilateral transaction between suppliers at node i and consumer at node j is T_{ij} .

By solving above optimization problem the generation schedule can be obtained and with this schedule lines flow can be found. Then check whether all line flows are within the maximum limits are not, if any (one or more) of line flow exceeds the limit that the line is said to be congested and it has to be relieved as quickly as possible. Here congestion is relieved by Distribution Generation (DG) unit is placed in optimal location of the system.

III. DISTRIBUTED GENERATION UNIT

Micro grid system is considered one of the solutions to fulfill the commitment of reliable power delivery for future power system. Distributed Generation (DG) in micro grid, which generate power from renewable energy sources (wind, photovoltaic, tidal, mini hydro, etc). Distributed Generation (DG) is any small scale power generation technology that provides electric power at a site closer to customer than central station generation. Operation of DG provides benefits to the utility operators, distributed generation owners and consumers in terms of reliability power supply, transmission loss compensation, reduction in transmission system expansion and enhancement of renewable power generation. Distributed Generation, while not a new concept, is beginning to become more of reality as the technology progresses.

Presently DG exists in battery-operated devices, portable generators, and automobiles. The power source and load are in close proximity and the source is tailored to a specific load. In this paper DG is used for relieve congestion in the transmission line, where optimal location of DG has been found by TLR sensitivity based method.

IV. OPTIMAL PLACEMENT OF DG UNIT

Transmission Line Relief (TLR) sensitivities can be considered as the inverse of Power Transfer Distribution Factors (PTDFs). Both TLR and PTDFs determine the sensitivity of the flow on a line to load curtailment or connecting DG unit at respect bus. PTDFs determine the sensitivity of the flow on an element such as transmission line to single power transfer. TLR determine the sensitivity of the flow on the single monitored element such as a transmission line to many different transactions in the system. In other word, TLR sensitivities gauge the sensitivity of single monitored elements to many different power transfers.

TLR sensitivity values at all the load buses for the congested line are considered and used for calculating the necessary connecting DG for the alleviation of transmission line congestion. The TLR sensitivity at load bus k for a congested line $i - j$ is S_{ij}^k and is calculated by

$$S_{ij}^k = \frac{\overline{\Delta P_{ij}}}{\Delta P_k} \quad (10)$$

The excess power flow on transmission line $i - j$ is given by

$$\overline{\Delta P_{ij}} = P_{ij} - \overline{P_{ij}} \quad (11)$$

where

P_{ij} : Actual power flow through the transmission line $i - j$

\overline{P}_{ij} : Flow limits of transmission line $i - j$

The new generation P_k^{New} at load bus k can be calculated by

$$P_k^{New} = P_k + \frac{S_{ij}^k}{\sum_{i=1}^N S_{ij}^k} \overline{\Delta P}_{ij} \quad (12)$$

where,

P_k^{New} : After DG is connected at Load bus k

P_k : Before DG is connected at load bus k

S_{ij}^k : Sensitivity of power flow on line $i - j$ due to generation change at load bus k by Connected DG unit

N : Total no of load buses in the system

The lower the TLR sensitivity the more effect of a single MW power transfer at any two buses. So, based on the TLR sensitivity values the load curtailment or generate power by DG at load in required amounts at the load buses in order to eliminate the transmission congestion on the congested line $i - j$. Calculate TLR sensitivity of the system with respective congested line and find the most negative TLR sensitivity at load bus, which is the most optimal location for connected DG in the system.

V. TEST RESULTS

A. IEEE 14 Bus Systems

IEEE 14 Bus system has been taken as test bus in deregulated power system. Data of test bus system are taken form [14].

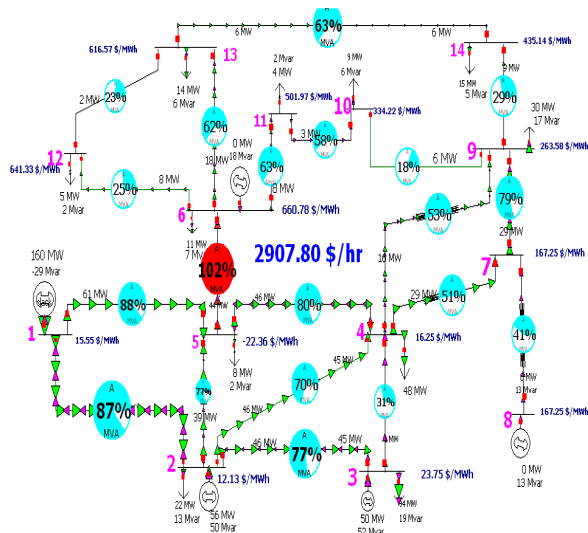

Fig. 1 Modified IEEE 14 Bus Systems with Congested Line 10 (Between Bus 5-6)

Fig. 1 shows, modified IEEE14 bus system and congestion is created by the loads are increased 50 percentages at each bus. Solve Optimal Power Flow (OPF) solution with primal linear programming method; IEEE 14 bus systems have total demand (259.3 MW & 79.8 MVAR), generation (268 MW &

102.7 MVAR) and loss (8.69 MW & 23.80 MVAR). After OPF solution check whether all line flows are within the maximum limits are not, where the line 10 (between buses 5-6) is congested due to transfer limit exceeds. Congested system the marginal cost per unit is different at each bus, total generation cost of the system per hour is: 2907.80 \$/h.

The remedial action has been taken by Distributed Generation unit. Here the placement of the DG is fund through Transmission Line Relief sensitivity performance index approach. Find the TLR sensitivity value at each load bus with respect to congested line 10, which is connected between buses 5-6.

The values of TLR sensitivity are given in Table I. the most negative TLR sensitivity value is found at bus 12, which is the best location to connect DG in the system. A 2MW Distribution Generation (DG) is connected at bus 12 to relieve congestion in transmission line 10.

TABLE I
IEEE 14 BUS TLR SENSITIVITIES

Sl. No	Load bus Number	TLR Sensitivity	Hourly System Power Generation Cost: \$/h
1	4	0.129	2893.37
2	5	0.162	2893.66
3	7	-0.034	2893.36
4	9	-0.137	2893.35
5	10	-0.210	2893.25
6	11	-0.382	2892.83
7	12	-0.524	2892.59
8	13	-0.499	2892.71
9	14	-0.315	2892.96

Fig. 2 shows, the congestion has been alleviated in line 10 (between buses 5-6) by 2 MW DG unit connected at bus 12, where the system congestion as well as total power generation cost per hour is reduced (2907.80 - 2892.59 \$/h) by 15.21 \$/h, the average marginal cost per MW at each bus is 12.81 \$/MWh. Here the cost of DG unit for generating 2 MW per hour is not considered. If the cost of DG unit 2MW/h is less than 15.21 \$/h it is more economical, or If the cost of DG unit 2MW/h is more than 15.21 \$/h it is reasonable cost of the system, but the main intention of this paper is reduce the congestion in the system.

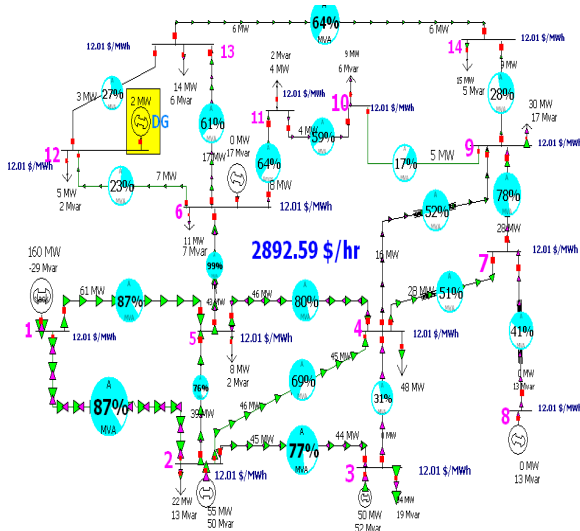

Fig. 2 Modified IEEE 14 Bus Systems with Uncongested Line 10 (Between Bus 5-6)

B. IEEE 30 Bus Systems

IEEE 30 Bus system has been taken as test bus in deregulated power system. Data of test bus system are taken form [14].

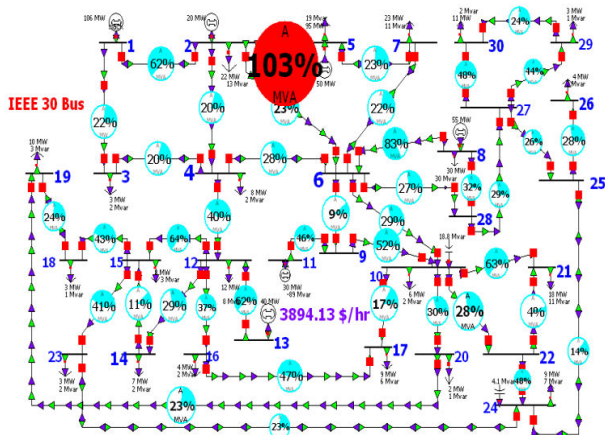

Fig. 3 Modified IEEE 30 Bus Systems with Congested Line 4 (Between Bus 2-5)

Fig. 3 shows, modified IEEE 30 bus system and congestion is created by the loads are increased 40 percentages at each bus. Solve Optimal Power Flow (OPF) solution with primal linear programming method; IEEE 30 bus systems have total demand (290 MW & 130 MVAR), generation (301.7 MW & 122.05 MVAR) and loss (11.73 MW & 7.95 MVAR). After OPF solution check whether all line flows are within the maximum limits are not, where the line 4 (between buses 2-5) is congested due to transfer limit exceeds. Congested system the marginal cost per unit is different at each bus, total generation cost of the system per hour is: 3931.41 \$/h.

The remedial action has been taken by Distributed Generation unit. Here the placement of the DG is fund through

Transmission Line Relief sensitivity performance index approach. Find the TLR sensitivity value at each load bus with respect to congested line 4, which is connected between buses 2-5.

The values of TLR sensitivity are given in Table II. The most negative TLR sensitivity value is found at bus 7, which is the best location to connect DG in the system. A 2.4 MW Distribution Generation (DG) is connected at bus 7 to relieve congestion in transmission line 4.

TABLE II
IEEE 30 BUS TLR SENSITIVITIES

Sl. No	Load bus Number	TLR Sensitivity	Hourly System Power Generation Cost: \$/h
1	7	-0.243	3863.36
2	19	0.039	3864.58
3	20	0.038	3864.90
4	21	0.035	3865.02
5	26	0.022	3865.15
6	27	0.025	3865.07
7	28	0.021	3864.03
8	29	0.017	3864.10
9	30	0.012	3863.55

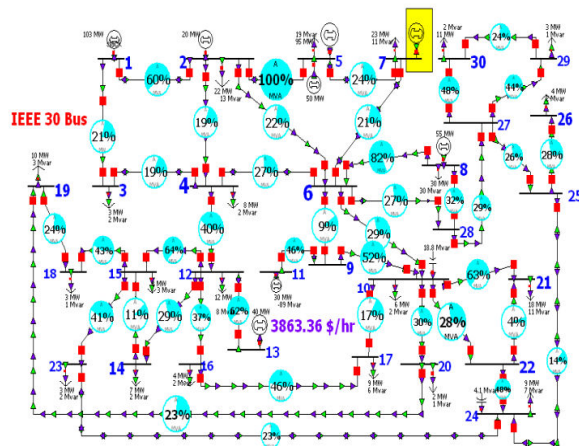

Fig. 4 Modified IEEE 30 Bus Systems with Uncongested Line 4 (Between Bus 2-5)

Fig. 4 shows, the congestion has been alleviated in line 4 (between buses 2-5) by 3 MW DG unit connected at bus 7. Where the system congestion as well as total power generation cost per hour is reduced (3894.13-3863.36 \$/h) by 30.77 \$/h, the average marginal cost per MW at each bus is 13.36 \$/MWh. Here the cost of DG unit for generating 2.4 MW per hour is not considered. If the cost of DG unit 2.4 MW/h is less than 30.77 \$/h it is more economical, or If the cost of DG unit 2.4 MW/h is more than 30.77 \$/h it is reasonable cost of the system, but the main intention of this paper is reduce the congestion in the system.

VI. CONCLUSION

Congestion management is an important issue in deregulated power systems. IEEE 14 and 30 bus test systems have been modeled in deregulated environment, where the

congestion in the transmission is determined by optimal power flow solution, which is carried primal linear programming method. Connected DG at load bus can help to reduce the flows in heavily loaded lines. It is important to obtain optimal location for placement of Distributed Generation (DG) unit for good performance of the system. The results presented in this paper show that Transmission Line Relief (TLR) sensitivity index used for determining optimal location of DG unit. The congestion in transmission lines of IEEE 14 and 30 bus test systems are alleviated by connected optimal placement of DG at load buses.

ACKNOWLEDGMENT

This work has been supported by National Institute of Technology Calicut for progress review of Ph .D work in year Dec 2013.

REFERENCES

- [1] R. H. Lasseter, "Micro grids," Power Engineering Society Winter Meeting, Vol. 1, pp.305-308, 2002.
- [2] Ritwik Majumder, Student Member, IEEE, "Power Management and Power Flow Control with Back-to-Back Converters in a Utility Connected Micro grid", IEEE Trans. Power Syst., vol. 25, no. 2, May 2010.
- [3] Guguloth Ramesh, T.K. Sunil Kumar, "Active and reactive power flow control in a grid connected and autonomous microgrid", International review and modeling and simulation, Vol.6, No.2, ISSN 1974-9821, April 2013.
- [4] A.R. Abhyankar, S.A. Kaparde, "Restructured power systems", text book, march 2011.
- [5] Loi Lei Lai, "Power systems restructuring and deregulation: trading, performance and information technology", Jhon Wiley and Sons ltd, textbook, 2001.
- [6] Keshi Reddy Saidi Reddy1, Narayana Prasad Padhy, "Congestion management in deregulated power system using FACTS devices", IEEE conference 2006.
- [7] Richard D. Christie, and Bruce F. Wollenberg, "Transmission management in the deregulated environment", Proceeding of the IEEE, Vol.88, No.2, Feb 2000.
- [8] Ashwani Kumar, S.C. Srivastava, "Congestion management in competitive market: a bibliography survey", Electrical power system research, 76(2005) 153-164.
- [9] K. Vijay Kumar and Jagadeshan, "Optimal location and sizing DG for congestion management in deregulated power systems", pp.679-686, springer-verlag berlin heidelberg 2012.
- [10] Jibiki. T, Sakakibara .E, "Line flow sensitivities of line reactances for congestion management", IEEE Power Engi. Society Meeting, Vol.24, pp.1-6, June 2007.
- [11] H. A. Gil, and G. Joos, "Models for quantifying the economic benefits of distributed generation," IEEE Trans. Power Syst., vol. 23, no. 2, pp. 327-335, May. 2008.
- [12] M. Afkousi-Paqaleh, M. Rashidinejad, "Transmission Congestion Management Using Distributed Generation Considering Load Uncertainty", Sharif University of Technology, Tehran, Iran. IEEE conference 2010.
- [13] Yan H.H, "PTDF and TLR from a power market perspective", IEEE Power engineering society summer meeting, Vol.3, pp.1645-49, July 2002.
- [14] Rich Christie, "Power System Test Case Archive", University of Washington Electrical Engineering, Aug 1993.

Department at Christu Jyothi Institute of Technology and Science under JNTU Hyderabad in the year 2008, M .Tech from Electrical Engineering Department with Power System Specialization at NIT Calicut, in the year 2011. His interested areas in Research are Power Systems, Restructuring Power Systems, Flexible AC Transmission System, and Micro grid.



Dr .T.K. Sunil Kumar, Assistant Professor , Electrical Engineering Department, NIT Calicut, Kerala -673601, India. He completed B. Tech in Electrical Engineering at N.S.S College of Engineering, Palakkad. He has completed M .Tech in Electrical Engineering at NIT Jamshedpur, and Ph. D. from IIT Kharagpur. His interested areas are Model Matching Controller Design Methods with Applications in Electric Power Systems, Restructuring Power Systems, Flexible AC Transmission System, and Micro grid.



Guguloth Ramesh is currently Research Scholar in Electrical Engineering Department, National Institute of Technology, Calicut, Kerala -673601, India. Date of Birth 23-05-1987. He completed B. Tech Electrical engineering