

Sewer Culvert Installation Method to Accommodate Underground Construction in an Urban Area with Narrow Streets (The Development of Shield Switching Type Micro-Tunneling Method and the Introduction of Construction Examples)

Osamu Igawa, Hiroshi Kouchiwa, Yuji Ito

Abstract—In recent years, a reconstruction project for sewer pipelines has been progressing in Japan with the aim of renewing old sewer culverts. However, it is difficult to secure a sufficient base area for shafts in an urban area because many streets are narrow with a complex layout. As a result, construction in such urban areas is generally very demanding.

In urban areas, there is a strong requirement for a safe, reliable and economical construction method that does not disturb the public's daily life and urban activities. With this in mind, we developed a new construction method called the "shield switching type micro-tunneling method," which integrates the micro-tunneling method and shield method.

In this method, pipeline is constructed first for sections that are gently curved or straight using the economical micro-tunneling method, and then the method is switched to the shield method for sections with a sharp curve or a series of curves without establishing an intermediate shaft.

This paper provides the information, features and construction examples of this newly developed method.

Keywords—Micro-tunneling method, Secondary lining applied RC segment, Sharp curve, Shield method, Switching type.

I. INTRODUCTION

IN recent years, a reconstruction project for sewer pipelines has been progressing in Japan with the aim of renewing old sewer culverts. However, it is difficult to secure sufficient work yard space in an urban area because many streets are narrow with a complex layout, and there are also many objects buried underground. As a result, construction in such urban areas is generally very demanding.

There is a strong requirement for a safe, reliable and economical construction method that does not disturb the public's daily life and urban activities, and for this reason, many pipelines are constructed using the non-open cut method [1], [2].

Construction techniques for sewer pipelines using the non-open cut method include the shield method and

micro-tunneling method. Both methods share the same equipment including a tunnel boring machine, facility specifications, and principles and rules. However, currently it is common practice to select one or the other of the methods, and there is no case for using both methods combined.

Under these circumstances, we developed a new construction method called the "shield switching type micro-tunneling method," which integrates the micro-tunneling method and shield method.

II. OVERVIEW OF THE CONSTRUCTION METHOD

The shield switching type micro-tunneling method takes full advantage of both the micro-tunneling method and shield method. In this method, the pipeline is constructed first for sections that are gently curved or straight using the economical micro-tunneling method, and then the method is switched to the shield method for sections with a sharp curve or a series of curves without building an intermediate shaft (Fig. 1).

Since the slurry pipe jacking is used for the tunnel-boring system, this method does not require a slurry water treatment plant. As a result, the work yard area can be greatly reduced compared to the conventional shield method.

This method is used for cases with a final inner diameter of 1,000mm to 2,200mm. By taking full advantage of the micro-tunneling method, this method can reduce the total costs, etc. of the construction of pipeline with a sharp curve and long distance pipeline by applying the shield method for sections where the micro-tunneling method is not suitable.

Since the external diameters of segments and micro-tunneling pipe are different at the shield switching point, they are connected with a steel adapter ring (a component that connects a segment and micro-tunneling pipe), (Fig. 2).

Osamu Igawa, Hiroshi Kouchiwa, and Yuji Ito are with the Japan Institute of Wastewater Engineering and Technology (JIWET), 7th Suido-cho Building 3-1, Suido-cho, Shinjuku-ku, Tokyo, Japan (phone: 81-3-5228-6598; fax: 81-3-5228-6512; e-mail: o-igawa@jiwet.or.jp, h-kouchiwa@jiwet.or.jp, y-itou@jiwet.or.jp).

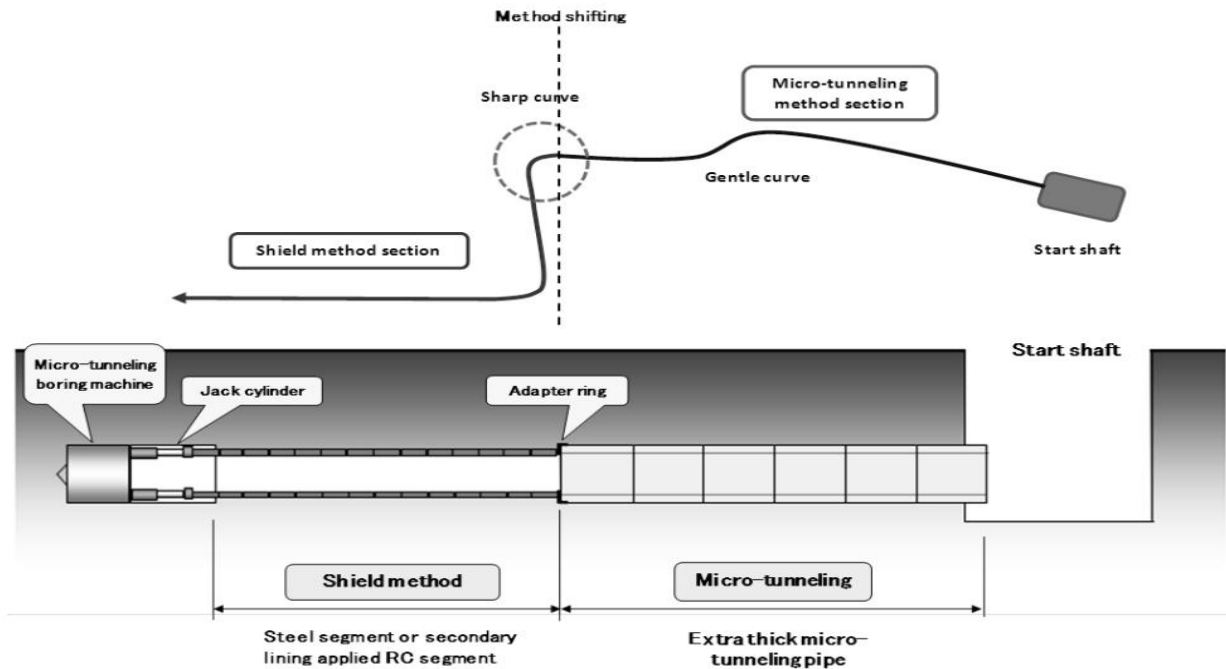

Fig. 1 Overview of the shield switching type micro-tunneling method



Fig. 2 Switching point between the shield method and micro-tunneling sections

A. Construction Method

In this construction method, segments and adapter rings (a connection ring between segments and micro-tunneling pipe) are installed inside the tunnel boring machine in advance, and the micro-tunneling pipe is then connected at the end. In this state, the tunnel boring machine is driven in the same way as the micro-tunneling method using a base-pushing jack until it reaches a predetermined method switching point [3], [4].

Then, it is driven in the same way as the shield method using a shield jack that is installed inside the tunnel boring machine to continue tunnel boring while replenishing the segments.

B. Types of Construction Method

There are two types of construction methods; “conventional type” and “secondary lining applied type.” They are

categorized by the materials used for shield method sections.

1. Conventional Type (Using Steel Segments)

The conventional type is a two-step system in which steel segments are used as a primary lining, and then a secondary lining is installed after reaching to the end point. The secondary lining is finished using the inner lining method. Applying the inner lining method allowed us to reduce the drilling cross section and shorten the construction period.

2. Secondary Lining Applied Type (Using Concrete Segments)

The secondary lining applied type is a one-step system that does not require secondary lining, in which the RC segments with a shield layer (50mm) and a body structure layer (125mm) are used to finish the lining with a completely smooth inner surface. For this reason, this method allows the process of secondary lining to be omitted and the construction period shortened. This method can be applied in cases where the final inner diameter is $\phi 1, 650\text{mm}$ or more [5].

C. Features of the Construction Method

The greatest feature of this construction method is that it integrates both the “shield method” and “micro-tunneling method” as described in the above section.

1. Construction at Sections with a Sharp Curve and Long Distance

This method is applicable for construction involving sharp curves up to a curve radius of $R = 10\text{m}$. At the same time, long distance construction is possible after sharp curve construction. Hence, this method is suitable for underground construction in a confined urban area.

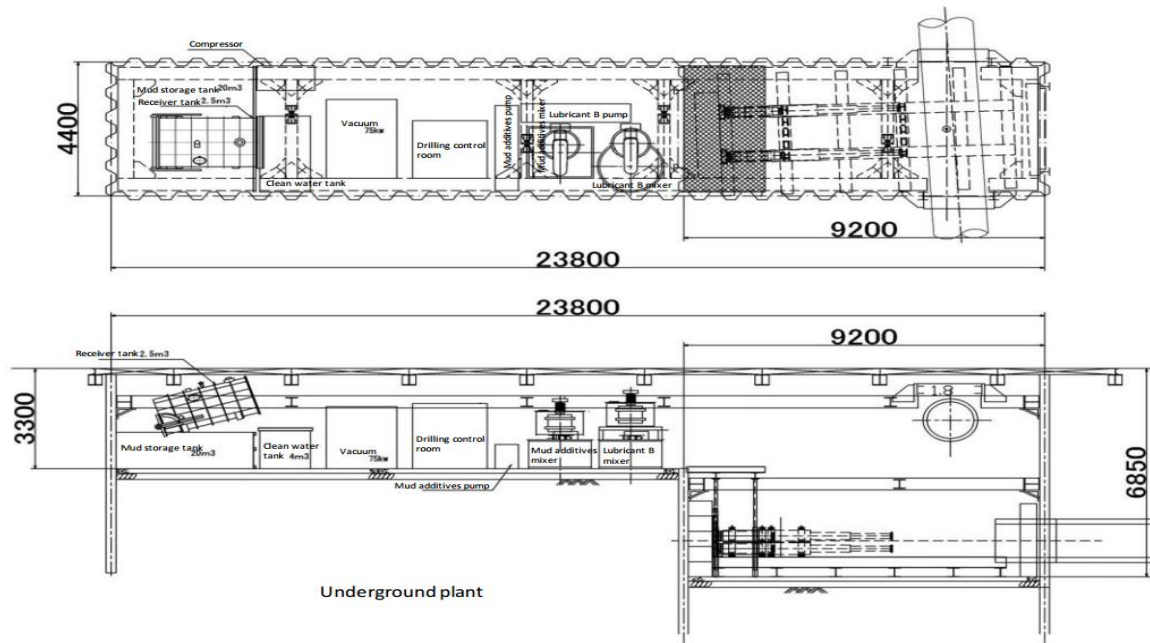

Fig. 3 Example of an underground plant

2. Simplified Start Facility (Plant and Shaft Facility)

The soil removal system is based on the macro-tunneling method (slurry pipe jacking), and the area occupied for the start facility is approximately 20% less than that in the mud pressure shield method (Table I). This method can be diversified into the following three types of methods depending on the site conditions (installation requirements for the start shaft).

a) Stationary Plant

This plant system is established in a permanent work area on a road or alongside a road. The advantage of this plant is that there is no need to establish a work area, etc., which results in an increased work efficiency. However, it is prone to suffering restrictions resulting from the site conditions of the plant if construction is taking place in an urban area.

b) On-board Vehicle Plant

A set of plant facilities is installed on a truck so that a plant can be established on the road. The advantages of this plant are that the road can be completely opened at the end of each day, and it is possible to conduct construction at a site where there is not enough space for a plant.

c) Underground Plant

In this plant system, a plant site is established with the start shaft (sub-shaft format) using temporary materials such as steel sheet pile, etc. (Fig. 3). Because the operation is conducted inside the sub-shaft, this plant has an advantage in applications where noise and vibration are of concern. Only a few working machines such as a mobile crane or vacuum car, etc. are on the road deck panel, meaning that it does not require a large work space and can minimize impact on the residents.

TABLE I
COMPARISONS OF WORK YARD AREAS

Method	Standard work yard area(m ²)	Comparison
Mud pressure shield method (Final inner diameter 1500mm)	454 (28.4 x 16.0 m)	100%
Shield switching type micro-tunneling method (Final inner diameter 1500 mm)	368 (23.0 x 16.0 m)	81.1%

3. Superior Economic Efficiency (Compared with the Shield Method)

The cost of a "micro-tunneling method section" is less than that of a "shield method section" because micro-tunneling pipes are used. Therefore, the longer the micro-tunneling section, the greater the economic efficiency of the design.

4. Shortened Construction Period with the Adoption of Secondary Lining Applied RC Segments

With the use of secondary lining applied RC segments with a completely smooth inner surface, this method does not require the application of secondary lining, resulting in a great reduction in the construction period.

D.Scope of Application

- Final inner diameter: $\phi 1,000$ to $\phi 2,200$ mm ($\phi 1,650$ mm or more for the secondary lining applied type)
- Maximum construction length: $L = 1,300$ m
- Minimum curve diameter: $R = 10$ m

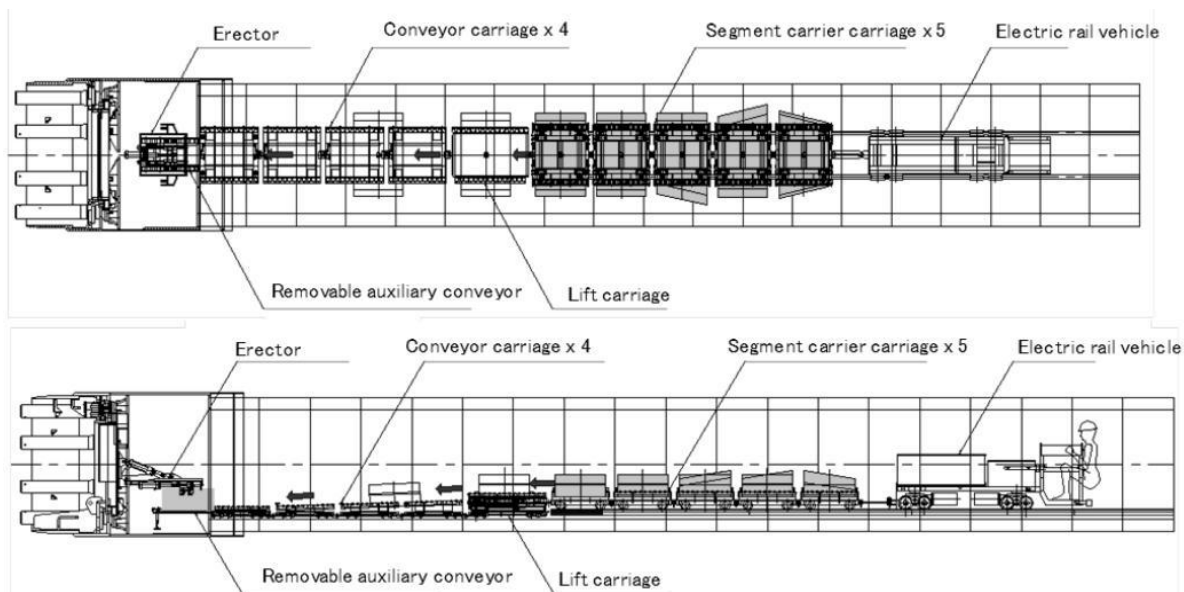

Fig. 4 Conveyor system

III. DEVELOPMENT OF SECONDARY LINING APPLIED TYPE

The difference between the “conventional type” and “secondary lining applied type” is the difference in the materials used in the segments as described in the above section. This difference in materials can greatly influence the way the segments are transported to the drilling face. The reason for this is the weight of the segment itself (e.g. an RC segment can weigh 200 kg or more per piece).

For example, a whole ring (5 pieces) of steel segments can be loaded per carriage, whereas only one piece of RC segment can be loaded per carriage. As a result, 5 carriages are required to transport one ring for RC segments. In addition, steel segments can be carried from the carriage to the installation site at the drilling face using manpower, but it is difficult to do so for RC segments. With this background in mind, we developed the “conveyor system for secondary lining applied RC segments” and “RC segments” in order to be able to carry out a series of work processes using manpower.

A. Conveyor System for the Secondary Lining Applied RC Segment

This conveyor system uses a total of 12 carriages as shown in Fig. 4 and Table II. In the conventional system RC segments could not be installed by manpower, but this system allows easy installation of segments by combining the conveyor and lift carriages. In this conveyor system, rollers are installed at the bottom of each carriage to allow the segments to slide.

With the development of this system, it is possible to transport the segments without requiring a large area, and also it is possible to transfer segments with an inner diameter of 1,000 mm.

TABLE II
CARRIAGE CONFIGURATION OF THE CONVEYOR SYSTEM

Name	Number of units
Electric railway vehicle	1
Segment carrier carriage	5
Lift carriage	1
Conveyor carriage	4
Removable auxiliary conveyor	1

B. Secondary Lining Applied RC Segment

The greatest feature of this segment is that the thickness of the shield layer is set to be at 50mm. By maintaining this thickness, it does not adversely affect future reinforcement arrangement of the segments, meaning it can achieve a long service life. The segment structure is shown below (Fig. 5).

[Segment structure]

- RC structure (shield layer 50mm, body structure 125mm)
- Smooth inner surface type
- Joint structure: Rigid joint (Between rings: Push grip, between pieces: Slide cotter)
- Evenly spaced 5-division system

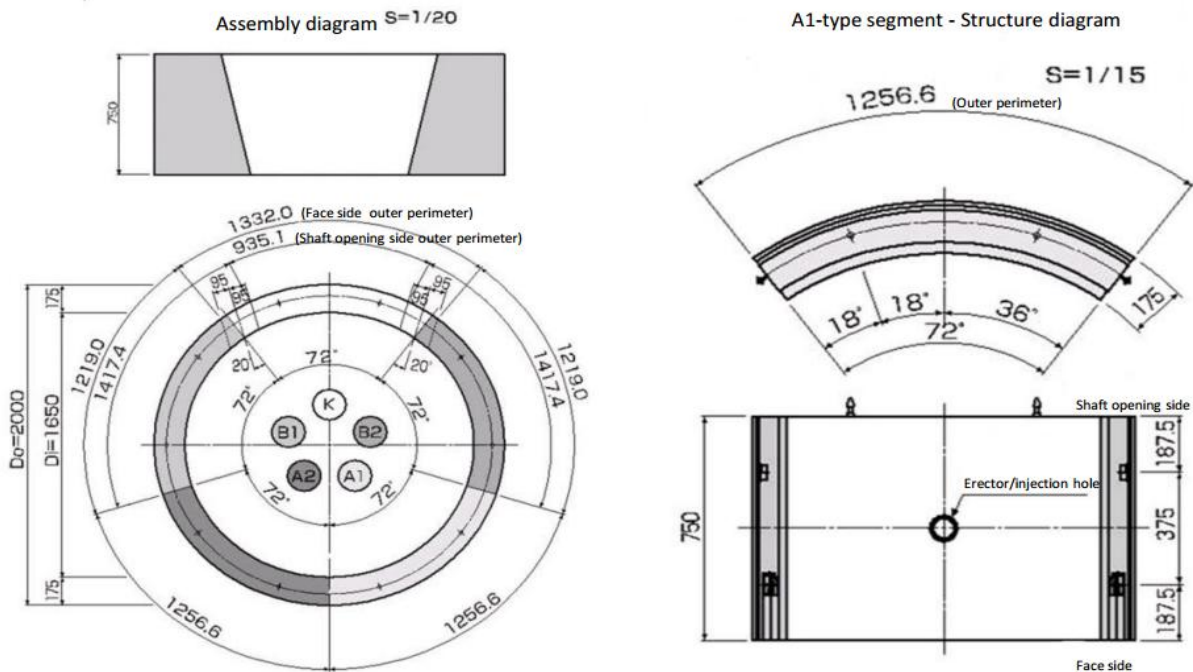

Fig. 5 Segment Structure



Fig. 6 Secondary lining applied RC segment – assembly

IV. CONSTRUCTION EXAMPLE

A. Construction Overview

Construction period: From Nov. 1, 2008 to Oct. 31, 2009

Construction time: 8 hours of day-time construction (the road at the start shaft reopened after construction)

Plant type: Stationary plant (occupied area = 120m²)

Final inner diameter: $\phi 1,350\text{mm}$

Construction length: Total length = 780.1m
 Micro-tunneling method section = 300.0m
 Shield method section = 480.1m
 Curves: 9 locations (length of curve section = 197.0m)
 Curve radius: $R = 12\text{m}, 40\text{m}, 50\text{m}, 100\text{m}, 150\text{m}, 200\text{m} \times 4$ locations
 Soil conditions: Sandy clay $N=12$ (some were sand gravel layers.)

B. The Reasons for This Construction Method to Be Adopted

The construction site was located in an expensive residential area, and there was heavy traffic on the road. Although some parts of the road at the start shaft had a width of 6.5 m (including sidewalk), most had a width of approximately 4.0 m. Under such conditions, we were able to obtain the land space for start shaft, but it was difficult to secure space for the work yard and mid-start shaft.

Thus, in order to carry out construction under these conditions, it was necessary to satisfy the following requirements; therefore, this construction method was selected.

- A length of $L = 780\text{m}$ can be constructed in one section.
- The area of the work yard should be 120m² or less.
- The construction site is able to handle a sharp curve with $R = 12\text{m}$.
- The noise and vibration should be within regulatory limits.
- The road should be open at the end of each day of construction work.



Fig. 7 Work yard

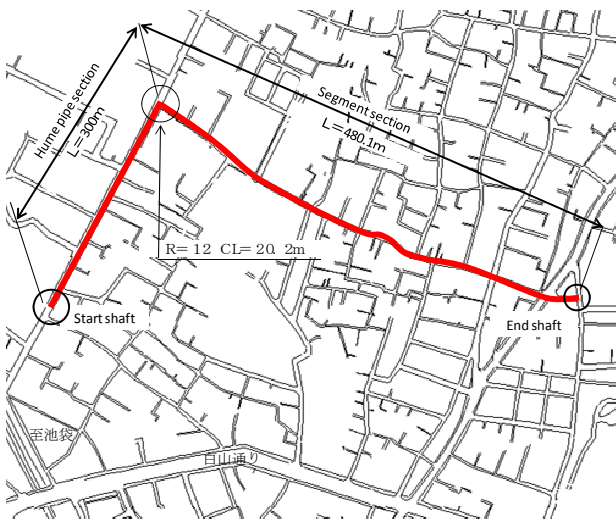

Fig. 8 Construction line



Fig. 9 Shield switching type micro-tunneling method - tunnel boring machine

construction method in the future, we hope to contribute to the renewal of aging pipelines and the promotion of flood protection measures.

REFERENCES

- [1] Japan Society of Civil Engineers, "Standard specifications for tunneling 2006 shield tunnels" Japan Society of Civil Engineers Tunnel Engineering Committee, The Standard Specifications for Tunneling Subcommittee, 2007.
- [2] Japan Sewage Works Association, "Design Standard for Sewerage Micro-Tunneling Method", Japan Sewage Works Association, 2010.
- [3] Japan Sewage Works Association, "JSWAS Reinforced Pipe (RCP) for Sewerage Micro-Tunneling Method (A-2)", Japan Sewage Works Association, 1999.
- [4] Japan Sewage Works Association, "JSWAS Glass Fiber Reinforced Pipe for Sewerage Micro-Tunneling Method (A-8)", Japan Sewage Works Association, 2013.
- [5] Japan Sewage Works Association, "Standard Segment for Shield Tunneling Method (A-3, 4)", Japan Sewage Works Association, 2001.

V. CONCLUSIONS

The development of this technology can help to facilitate pipeline construction in a densely populated site such as Japanese urban area. Through the widespread use of this