

Evaluating and Measuring the Performance Parameters of Agricultural Wheels

Ali Roozbahani, Aref Mardani, Roohollah Jokar, Hamid Taghavifar

Abstract—Evaluating and measuring the performance parameters of wheels and tillage equipments under controlled conditions obligates the use of soil bin facility. In this research designing, constructing and evaluating a single-wheel tester has been studied inside a soil bin. The tested wheel was directly driven by the electric motor. Vertical load was applied by a power bolt on wheel. This tester can measure required draft force, the depth of tire sinkage, contact area between wheel and soil, and soil stress at different depths and in the both alongside and perpendicular to the direction of traversing. In order to evaluate the system preparation, traction force was measured by the connected S-shaped load cell as arms between the wheel-tester and carriage. Treatments of forward speed, slip, and vertical load at a constant pressure were investigated in a complete randomized block design. The results indicated that the traction force increased at constant wheel load. The results revealed that the maximum traction force was observed within the %15 of slip.

Keywords—Slip, single wheel-tester, soil bin, soil-machine, speed, traction.

I. INTRODUCTION

TRACTION performance of agricultural wheels can be measured at farm by wheel-tester or tractors. Farm measurements are often unreliable due to inconsistencies in soil conditions and sudden changes. Factors that affect tire performance are so complex and therefore make it difficult to determine the impact of each factor. Although the tester systems are considered somewhat of an artificial environment, but if the proper equipment is being utilized to control soil conditions, it is easily to manage the objective parameters and yield highly accurate results. Then again, many computer modeling have been applied in soil wheel interaction domain. Hence, a controlled condition to obtain reliable empirical data is necessary. When the wheel is equipped with pneumatic tire, the privilege of applying only one unit in soil bin facilities is considerable.

Al-Janobi and M. Zein Eldin [1] developed an indoor soil-bin test facility for soil-tillage tool interaction studies. It included a stationary soil-bin, a carriage and control unit. The instrumentation system consisted of an extended octagonal ring transducer for measuring force a magnetic pickup to check velocity. Kawase et al. [2] developed an indoor traction

measurement system consisting single wheel tester, mixing and compaction device for soil processing, soil bin and traction load device. This facility provided the ability to investigate the tire driving torque, sinkage, velocity, and positioning the tire lug. Tiwari et al. [3] developed a tire traction testing facility which was capable of giving continuous reading of forward speed, wheel speed, draft force and torque. It could provide either of constant or varying slippages and tractions. Upadhyaya et al. [4] designed and constructed a single wheel traction machine to study soil-wheel interactions. The objective parameters to be examined were velocity, wheel load, torque and traction by two controlling methods for slippage and traction. However, this machine had the disadvantage of restriction in wheel load, engine operating condition and traction force. A field single wheel tester was introduced by Shmulevic et al. [5] featuring to conduct traction tests. The utilized tire was selected to bear heavy wheel loads, high traction forces and lateral forces and adapt tires with up to 2m diameter.

Others examined the development of single wheel-tester to perform traction tests. For instance, the National Soil Dynamic Laboratory in Auburn, USA [6], Silsoe Research Institute, UK [7], University of California at Davis, USA, with combination of farm tests and soil bin facility using a driven test tire towed by a tractor while the difference between the forward speed of the system and rotational speed of tire provided various slippages [4], and University of Hohenheim, Germany, with the conspicuous characteristic of driven angled wheel tester [8]. National Soil Dynamics Laboratory (NSDL) developed a single wheel-tester with hydraulic driving force in order to perform traction tests under various conditions of soil. This device provided the independent control of slippage and dynamic load while either of them could be constant and the other one varying. Wheel load over the tester developed by NSDL could be increased to 72 kN and traction up to 44.5 kN. A tester was designed and built [6]. The hydraulic controller was used for controlling the forward speed, wheel rotational speed and dynamic load. In NSDL collection of testers inside soil bin and farm were developed by Thomas in 2006 (Way, T.2007). A single wheel tester named NIAE Mk-II provided the experiments in farm with controlling slippage and forward speed and holding wide range of agricultural tires. This tester was capable to stand 27.2 kN wheel load and 25 kN draft force. One main drawback of this tester was its failure to provide various dynamic loads during the test.

The main purpose of this study was to provide a single-wheel tester with high capabilities in order to measure the parameters related to wheel and soil interactions as well as

Ali Roozbahani, Aref Mardani, and Roohollah Jokar are with the Mechanical Engineering of Agricultural Machinery Dept., Urmia University, Iran (e-mail: alirzbhn@gmail.com, a.mardani@urmia.ac.ir, jokar16@gmail.com).

Hamid Taghavifar is with the Mechanical Engineering of Agricultural Machinery Dept., Urmia University, Iran (corresponding author to provide phone: + 98 441 2770508; fax: + 98 441 277 1926; e-mail: hamid.taghavifar@gmail.com).

tools and soil interactions such as the traction force, rolling resistance, stress, contact area at different depths of soil and the effect the tire footprint. It follows to evaluate the system to investigate traction force resulting from vertical load on the wheel, cone index, slip and velocity.

II. TESTING FACILITY

A. General Preface

The tire traction facility comprised of an indoor soil bin, single wheel-tester, carriage, control panel, and soil processing equipments was designed by the Mechanical Engineering of Agricultural Machinery Department, Urmia University, Iran. A general view of the testing facility is demonstrated at Fig. 1.

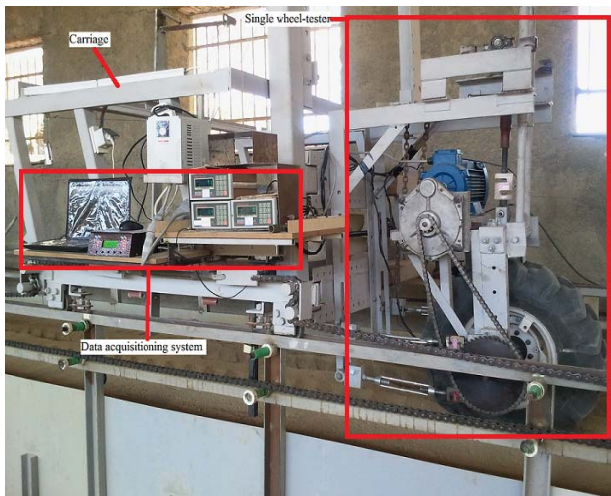

Fig. 1 General view of the testing facility

B. Soil Bin

The used soil bin featured 23m length, 2m width and 1m depth of soil channel filled with clay loam soil. The soil bin has a general carriage for mounting traction devices such as towed wheels. The carriage dimension is 1.90m × 2m × 0.95m with total weight of 485kg as shown in Fig. 2. At two sides of soil bin, a rail road was used to facilitate the movement of carriage and attached single wheel-tester along the soil channel. An electromotor with the power of 22 kW was used to pull a carriage on the sides of rail road through chain system. Chain system enabled the forward and reverse movement of the carriage. An inverter provided speed control for carriage. Particular equipments were used to organize soil bed including leveler and harrow since it is very important to have well-prepared soil inside soil bin for acquiring reliable and precise results from this experiment.

C. Single Wheel Tester

The single wheel tester consisted of a main frame to accommodate the various sizes of tires, lifting arms, a loading platform and a power transmission system. The U shape frame of wheel tester had the ability to be rotated around its vertical axis to form angled direction for movement. An L-shape frame connected the wheel-tester and carriage. An induction

motor of 5 kW, 3-phase, 1430 sync rev/minis was used to make driving power for the wheel. The speed of the motor was initially reduced by gear box (7.5:1) then reduced by a gear reduction unit (4.5:1) and the latest reduction ratio was (33.75:1). Detailed components of single wheel-tester along with carriage system are illustrated in Fig. 2. The tire was directly driven by the electric motor. An electric motor and an inverter were used to impose desired rotational speed for wheel. Difference between imposed rotational speed for wheel-tester and carriage speed provided preferred slippage. High privilege of this single wheel-tester was the ability to adjust the position of tester in the width of bin by means of a rotational handle that could control the movement of tester against with the centre of carriage. The installed electromotor and attached camshaft provided a definite algorithm of dynamic load while traversing in the length of soil bin.

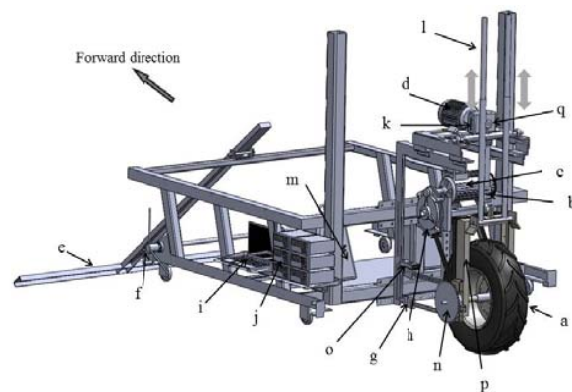

Fig. 2 Designed wheel carriage and components in SolidWorks software; Driving wheel (a), Load cell for wheel load (b), Electromotor for slippage (c), Electromotor to produce dynamic load (d), Leveler (e), The lever position leveling (f), Load cell measured the traction force (g), Gearbox (h), Data storage (laptop) (i), Digital indicators (j), Gear dynamic load (k), Telescopes to control lateral deviation of tester (l), loads (m), The sprocket wheel shaft (n), Horizontal arms for draft force (o), Wheel frame (p), Dynamic load camshaft (q)

D. Tools and Control Systems

Wheel carriage was driven in the two side rails by means of two chains utilizing a 3 phase electric motor made in Motogen Company with 30 hp (22 kW) and the nominal rotational speed of 1457 rpm. For rotational speed of the engine, a sv 220IS5 - 2 N O, 380V model of LG inverter (brand LS) weighing 20.3kg was used with an information display panel that enables the adjustment of the frequency of 0.1 Hz with the voltage. An induction motor of 5 kW, 3-phase, 1430 sync rev/min was used to provide driving power to the wheel-tester that the power transmission path was entered to wheel from the electromotor by a coupling shaft with reduction ratio of 7.5:1 and then entered to a gearbox sprocket with reduction ratio of 4.5:1 and then to the shaft of tire. Thus, the engine rotational speed was reduced before arriving to the wheel with the overall reduction ratio of 33.75:1. Frequency of the input voltage to the driving wheel was regulated with an inverter 5.5 kW, 3-phase model IG5A Construction LG Company (South

Korea). Frequency ranges from 0.5 to 50 Hz with adjustable intervals of 0.1 and 50 Hz providing the maximum rotational speed of the engine. By movement of carriage, an optic tachometer sends the signal indicating the carriage velocity to data acquisition system. Accordingly, speed control becomes applicable by means of speed control unit ranging from 0.05 to 5 m/s.

E. Speed and Slip Parameters Measurement

The wheel forward rate for a non-slip condition was measured. With the determined rotational speed and the rolling tire, linear speed of wheel was calibrated in frequency. The calibrated graph frequency of speed is shown in Fig. 4. The Theoretical slip was calculated as follows:

$$\text{Theoretical velocity: } \%S = \frac{V_t - V_c}{V_t} \times 100 \quad (1)$$

where V_t is single wheel-tester's speed, and V_c is carriage speed. The actual slip ratio and theoretical slip are drawn with line in Fig. 3.

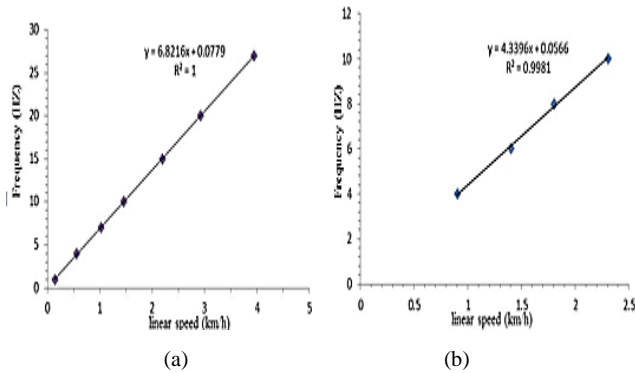

Fig. 3 Linear speed versus frequency (a) driving wheel (b) carriage

F. Data Acquisition System

The data acquisition system for the test is located in a special place on the carriage, as shown in Fig. 4. Four load cells were located on four parallel arms to measure the horizontal forces to determine traction force and another load cell was located on a bolt power of wheel to measure the vertical load on the wheel. Considering the symmetrical condition between the upper and lower forces, two upper load cells were connected to a digital indicator and two lower load cells to another digital indicator. The vertical load cell transmitted data to a separated digital indicator. Load cells sent data to a Bongshin digital indicator BS722 model and from output digital indicator by RS232 port to a Data Logger. In addition to synchronization, data sent by USB port to a computer and then were saved. Free diagram of forces on a wheel is shown in Fig. 5.



Fig. 4 The data acquisition system

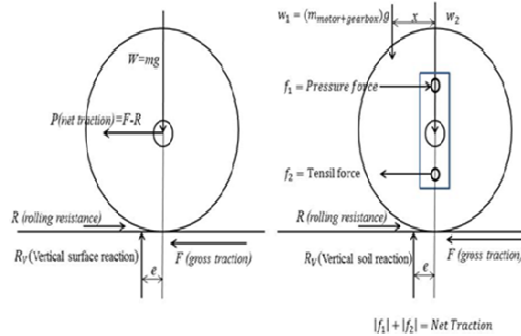

Fig. 5 Free diagram of forces on a wheel (a) model is built for the tester (b) general

G. Soil Preparation

The used soil bin features 23m length, 2m width and 1m depth. Soil channel was filled with clay loam soil. Soil in the soil bin was prepared manually to provide favorable conditions before each experiment. Soil was softened manually. Then, a leveler made even soil surface (Fig. 6). A RIMIK digital penetrometer device made in England was used to measure soil cone index (Fig. 7). Cone index was measured before and after each wheel traversing with three replicates along the centerline of tire. According to ASAE Standards S313.2 the penetration into the soil was performed with 0.2m/s constant velocity.



Fig. 6 The processed soil



Fig. 7 RIMIK digital penetrometer

H. Experiment Condition

Treatments of forward speed were considered in three levels of 0.3, 0.5 and 0.7m/s, slip in four levels 5%, 10%, 15% and 20%, vertical load in two levels 3.7 and 4.7kN, cone index in four levels. Before any test, the soil cone index was measured by this penetrometer.

III. RESULTS AND DISCUSSION

The initial tests revealed that the testing facility worked properly. The variables in this investigation were wheel load, slippage and velocity. Fig. 8 shows the dynamic load and draft force during data acquisition time at velocity of 0.3 m/s and slippage of %20. While the change of wheel load was negligible during the time, traction increased slightly with low inclination. Variation of traction coefficient is depicted in Fig. 9 and suggests increase of traction during the time of data acquisition. Fig. 10 demonstrates the traction force against variety of slippages. It suggests that at slippage of %5, traction force is 0.4kN and the describing curve increases with decreasing inclination wherein reaches the peak in between %13 and %15 slippage and starts to fall. It implies that traction increases within %15 of slippage and higher amount

of slippage creates resistive amount for traction efficiency. It is interpreted that the soil beneath the wheel is required to be compacted to let the wheel roll. The initial slippage provides the compacted soil in front of driven wheel but higher values of slippage, clearly, hinders the movement of wheel and traction.

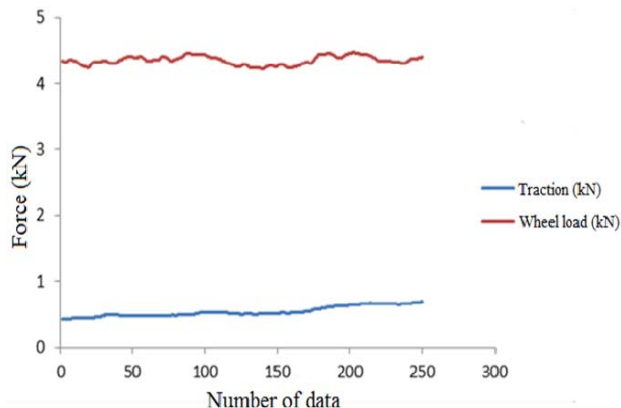

Fig. 8 Dynamic load and draft force during data acquisition time at velocity of 0.3 m/s and slippage of %20

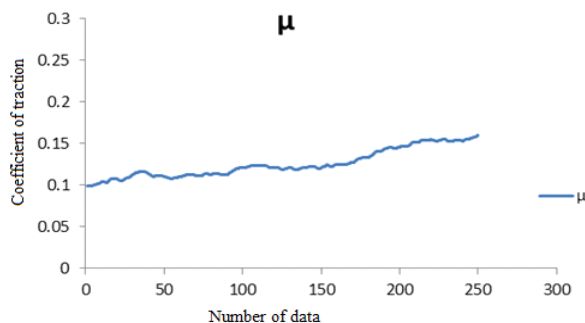

Fig. 9 Variation of traction coefficient during data acquisition time at velocity of 0.3 m/s and slippage of %20

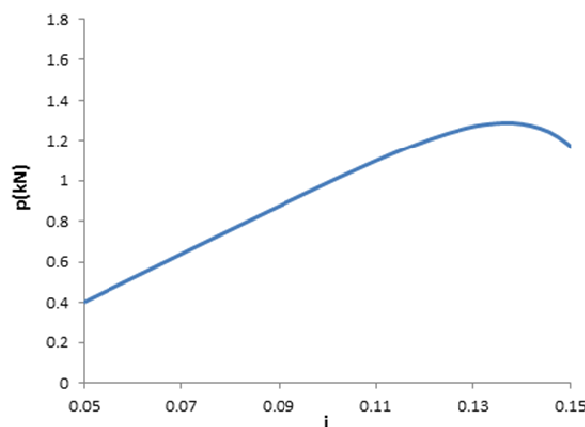

Fig. 10 Traction force against slip

IV. CONCLUSION

Modern off-road and agricultural vehicles with complex traction systems obligate designing controlled condition with well-equipped facility. The tire traction facility comprised of an indoor soil bin, single wheel-tester, carriage, control panel, and soil processing equipments was designed, constructed and evaluated. The tested wheel was directly driven by the electric motor. Vertical load was applied by a bolt power on wheel. The capacity to produce desired velocities as well as slippages and applying required wheel load and utilizing various tires with different dimensions along with the ability to give the preferred wheel angle, finding the depth of tire sinkage, contact area, and soil stress at different depths are the major privileges of this wheel tester. Proper data acquisition system tackled to receive data online, monitor them and save them for further analysis. Soil processing enabled creating suitable soil condition, leveling, tilling, compacting and changing the height of soil surface of giving desired inclination. Wheel load, slippage and velocity were variables to evaluate the constructed system. The results disclosed that traction and traction coefficient increase during the time of data acquisition while the change of wheel load was almost constant. Furthermore, it was yielded that traction force increases in 0-15% of wheel slippage with decreasing inclination to reach its peak wherein starts to fall. The results provided reasonable and accurate results approving the competences of constructed traction facility.

REFERENCES

- [1] Al-Janobi, A., Abdulrahman, M. and Zein Eldin, Abdalla, 1997. Development of a soil-bin test facility for soil-tillage tool interaction studies. Res. Bult., No (72), Agric. Res. Center, King Saud Univ., pp. (5-26).
- [2] Kawase, Y., Nakashima, H. and Oida A, 2006. An indoor traction measurement system for agricultural tires. Journal of Terramechanics, 43(3): 317-327.
- [3] Tiwari V.K., Pandey K.P. and Sharma A.K., 2009. Development of a tyre traction testing facility. Journal of Terramechanics, 46(6): 293-298.
- [4] Upadhyaya S.K., Mehkschau, J., Wulfsohn, D. and Glancey J.L., 1986. Development of a unique mobile single wheel traction testing machine. Trans ASAE, 29(5):1243-6.
- [5] Shmulevich, I., 1996. A new field single wheel tester. Journal of Terramechanics, 33(3):133-141.
- [6] Burt, E.C., Reaves, C.A., Bailey, A.C. and Pickering, W.D., 1980. A machine for testing tyres in soil bins. Trans ASAE, 23(3):546-7.
- [7] Billington, P.W., 1973. The NIAE Mk II single wheel tester. Journal of Agricultural Engineering Research, 18:67-70.
- [8] Ambruster, K. and Kutzbach, H.D., 1989. Development of a single wheel tester for measurement on driven angled wheel. In: Proceedings of 5th European conference of the ISTVS, Wageningen, The Netherlands, p. 8-14.