

Performance Analysis of Adaptive OFDM Pre and Post-FFT Beamforming System

S. Elnobi, Iman El-Zahaby, Amr M. Mahros

Abstract—In mobile communication systems, performance and capacity are affected by multi-path fading, delay spread and Co-Channel Interference (CCI). For this reason Orthogonal Frequency Division Multiplexing (OFDM) and adaptive antenna array are used is required. The goal of the OFDM is to improve the system performance against Inter-Symbol Interference (ISI). An array of adaptive antennas has been employed to suppress CCI by spatial technique. To suppress CCI in OFDM systems two main schemes the pre-FFT and the post-FFT have been proposed. In this paper, through a system level simulation, the behavior of the pre-FFT and post-FFT beamformers for OFDM system has been investigated based on two algorithms namely, Least Mean Squares (LMS) and Recursive Least Squares (RLS). The performance of the system is also discussed in multipath fading channel system specified by 3GPP Long Term Evolution (LTE).

Keywords—OFDM, Beamforming, Adaptive Antennas Array.

I. INTRODUCTION

MULTIPATH fading is due to the presence of many reflected signals, which arrive at the receiver at different times. These echoes cause inter symbol interference (ISI) and combined can produce fading. This effect is more and more severe as the distance range or the data rate of the system increase. Orthogonal Frequency Division Multiplexing (OFDM) is a potential candidate for future high-bit-rate wireless communication systems as is less susceptible to ISI introduced in the multipath environment. OFDM is a special form of multi carrier modulations that allows reliable transmission over a channel with a relatively large maximum delay. However when the delay of the arriving signals is longer than the guard interval, ISI causes severe degradations in the system performance. To solve this problem, a multiple antenna array can be used at the receiver, not only for spectral efficiency or gain enhancement, but also for interference suppression.

In an OFDM system, the beamforming algorithm can be applied in either time domain [1], [2] or frequency domain [3], [4]. Time domain array processing has lower complexity, because only one FFT is required. In frequency domain a processing of the individual subcarriers is provided, generally with better results, but always with higher complexity. Time-domain beamforming methods are normally called pre-FFT

Said M. Elnoubi is with the Electrical Engineering Department, Faculty of Engineering, Alexandria University, Egypt (e-mail: saidelnoubi@yahoo.com).

Amr M. Mahros and Iman El-Zahaby are with the Engineering Physics and Mathematics Department, Faculty of Engineering, Alexandria University, Egypt (e-mail: Amr.Mahros@mena.vt.edu).

Amr M. Mahros is now with Physics Department, King Abdulaziz University, Jeddah, Saudi Arabia.

whereas frequency-domain algorithms are called post-FFT. In this paper we analyze two beamforming algorithms, a low complexity pre-FFT and a more efficient post-FFT [3], by determining the optimum weights that satisfy the Least Mean Squares (LMS) criterion [4] and that satisfy the Recursive

Least Squares (RLS) Criterion [5]

The detailed comparison of the two methods, provided in this paper, can represent a key element in the design phase of an OFDM receiver equipped with a smart antenna, especially in the cases when it is a crucial problem to assess the best trade-off between complexity and performance. In literature only some partial results in terms of algorithm comparison are available [6]-[9]. Performance and computational complexity are studied, but only for the case of multipath delay within the guard interval; the analysis has been performed in different work conditions, in terms of channel model as well as applied algorithms. The organization of the paper includes a brief overview of an OFDM system, the pre-FFT and post-FFT beamforming methods in Section II. The LMS and RLS adaptive algorithms used in beamforming are discussed in Section III. Finally, Simulation results are then presented for typical pre-FFT and post-FFT followed by the results and conclusions from our simulations in multipath fading channel system specified by 3GPP, under different scenarios, in Section IV. We conclude with an examination of the LMS and RLS for OFDM pre and post-FFT beamforming in Section V.

II. SYSTEM MODEL AND BEAMFORMING SCHEMES

A. OFDM System

Fig. 1 illustrates the simplified block diagram of an OFDM system with an adaptive array at the receiver.

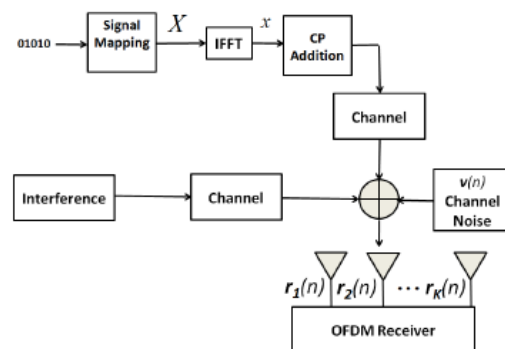

Fig. 1 An OFDM system with an antenna array the receiver

As it is shown in Fig. 1, data bits at the transmitter are first converted into a constellation map of a known modulation scheme such as QPSK or QAM. This data is interpreted as a frequency-domain data in an OFDM system and is subsequently converted to a time-domain signal by an IFFT operation. The output of the IFFT is transmitted to the channel after the addition of cyclic prefix (CP). This process can be written as,

$$x = \frac{1}{N} F^H X \quad (1)$$

$$x = [x(1) \ x(2) \ \dots \ x(N)]^T \quad (2)$$

$$X = [X(1) \ X(2) \ \dots \ X(N)]^T \quad (3)$$

$$F = \begin{bmatrix} 1 & 1 & \dots & \dots & 1 \\ 1 & e^{-j\frac{2\pi(1)(1)}{N}} & \dots & \dots & e^{-j\frac{2\pi(1)(N-1)}{N}} \\ \vdots & \vdots & \ddots & \ddots & \vdots \\ 1 & e^{-j\frac{2\pi(N-1)(1)}{N}} & \dots & \dots & e^{-j\frac{2\pi(N-1)(1)}{N}} \\ \vdots & \vdots & \dots & \dots & \vdots \end{bmatrix} \quad (4)$$

where x , X denote the time and frequency domain data vectors, respectively, F is the IFFT matrix operator, H denotes the Hermitian transpose, and N is the IFFT length. To add the CP, x is cyclically extended to generate \tilde{x} by inserting the last ν element of x at its beginning,

$$\tilde{x} = \begin{bmatrix} J_\nu \\ I_N \end{bmatrix} x \quad (5)$$

where J_ν contains the last ν rows of a size N identity matrix I_N .

Then the OFDM time signals are transformed to the appropriate analog form by D/A converter and be transmitted in wireless channel. We assume that a multipath channel model (frequency selective fading) with a maximum of L paths exists between the i^{th} source (desired or interference) and the antenna array in the form of

$$h_i(n) = \sum_{l=0}^{L-1} a_{i,l} \delta(n-l) \quad (6)$$

$$i = 1, 2, \dots, I$$

where I is the total number of sources and $a_{i,l}$ denotes a complex random number representing the l^{th} channel coefficient for the i^{th} source. Assuming that the CP is longer than the channel length ($\nu > L$), the received signal on the k^{th} antenna of a uniform linear array for one OFDM block will be given by,

$$r_k(n) = \sum_{i=1}^I \sum_{l=0}^{L-1} a_{i,l} \tilde{x}_i(n+l) e^{Z} + v_k(n) \quad (7)$$

$$Z = (-j \frac{2\pi}{\lambda} (k-1)d \cos(\theta_{i,l}))$$

$$1 \leq k \leq K, \quad 1 \leq n \leq N$$

in which K denotes the total number of antennas, λ represents the wavelength of the carrier, d denotes the inter-element

spacing, and $v_k(n)$ shows the channel noise entering the k^{th} antenna. $\theta_{i,l}$ denotes the angle of arrival the l^{th} path of the i^{th} source. Without loss of generality we have assumed here that the channels of all sources have the same length L and that the array is a uniform linear array.

B. Pre-FFT Beamforming

Fig. 2 illustrates the pre-FFT beamforming in the receiver of an OFDM system. After the CP removal, the received signal of each antenna is multiplied by its corresponding pre-FFT weight.

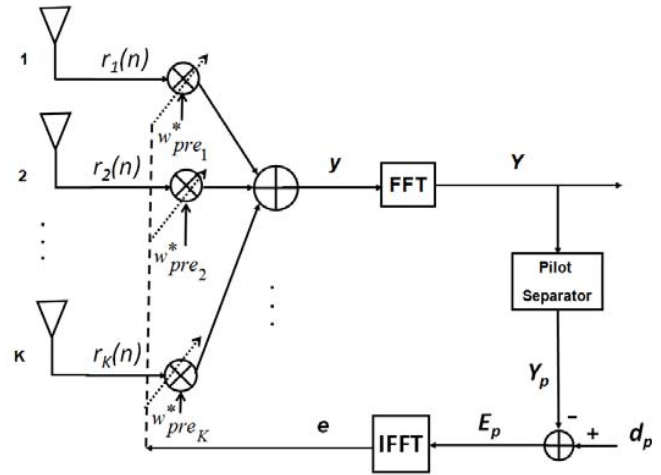

Fig. 2 Block diagram of the Pre-FFT OFDM

These signals are added together to construct the time-domain signal y . This signal is then converted to frequency domain by an FFT operation. The pre-FFT weights must be adjusted adaptively in every OFDM block. By comparing the received pilot symbols with their known values in the receiver an error signal is generated. Since this error signal is in frequency domain while pre-FFT weights are updated in time domain, the frequency-domain error signal must be converted to a time-domain error signal. If there are a total of P pilot symbols in every OFDM block then we define two $N \times I$ vector d_p and Y_p such that, the i^{th} element of d_p is zero if the i is a data subcarrier and is the known pilot value if i is a pilot subcarrier. Similarly, the i^{th} element of Y_p is zero if the i is a data subcarrier and is the received pilot value if i is a pilot subcarrier. Therefore, the error signal in frequency domain is given by:

$$E_p = d_p - Y_p \quad (8)$$

This error signal must be converted to time domain for the Pre-FFT weight adjustment algorithm. Therefore,

$$e = \frac{1}{N} F^H E_p \quad (9)$$

where e is $N \times I$ vector of error samples in time domain.

$$e = [e(1) \ e(2) \ \dots \ e(N)]^T \quad (10)$$

C. Post-FFT Beamforming

The block diagram of the post-FFT beamforming is shown in Fig. 3. The received time signal of each antenna is first converted to frequency domain. Beamforming is then performed on each subcarrier. If $R_{m,k}$ denotes the m^{th} subcarrier of the k^{th} antenna, then the (frequency-domain) output signal of m^{th} subcarrier is given by

$$Y(m) = \sum_{k=1}^K w_{m,k} R_{m,k}, \quad 1 \leq m \leq N \quad (11)$$

where $w_{m,k}$ represents the weight associated with $R_{m,k}$. As shown in Fig. 3 one weight is applied to every subcarrier. This is assuming that all subcarriers are pilot. Since there exist only a few pilots in each OFDM block, every group of adjacent data subcarriers are clustered under one pilot symbol and the weight of that pilot symbol is applied to all data subcarriers in the cluster.

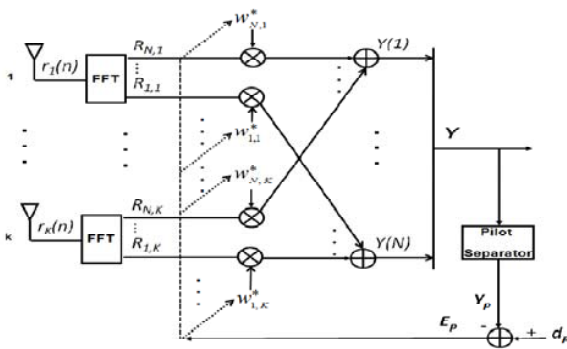

Fig. 3 Block diagram of the Post-FFT OFDM

By comparing the received pilot symbols with their known values in the receiver an error signal is generated. Since this error signal is in time domain and post-FFT weights are updated in time domain, the error signal would not be converted as in pre-FFT. Then the post-FFT weights are updated.

III. ADAPTIVE ALGORITHMS

The adaptive beamforming algorithms are used to update the weight vectors periodically to track the signal source in time varying environment by adaptively modifying the system's antenna pattern so that nulls are generated in the directions of the interference sources.

A. Least Mean Square (LMS) Algorithm

The LMS algorithm is a method of stochastically implementing the steepest descent algorithm. Successive corrections to the weight vector in the direction of the negative of the gradient vector eventually lead to the Minimum Mean Square Error (MMSE), at which point the weight vector assumes its optimum value. The equations employed are:

$$W(n) = W(n-1) + 2\mu r(n)e(n)^*, \quad 1 \leq n \leq N \quad (12)$$

where μ is the step size parameter, which controls the speed of

convergence, and $*$ represents the complex conjugate. The last update $W(N)$ at the end of each OFDM block is used as the initial value of the next block. The mean square error is increased with increase in step size and is decreased according to decrease in the step size.

B. Recursive Least Square (RLS) Algorithm

RLS is a deterministic algorithm in which the performance index is the sum of weighted error squares for the given data. The tap weight vector update equation is,

$$W(n) = W(n-1) + g(n)e(n)^*, \quad 1 \leq n \leq N \quad (13)$$

where,

$$g(n) = \frac{\alpha^{-1} R_{xx}^{-1}(n-1)y(n)}{1 + \alpha^{-1} R_{xx}^{-1}(n-1)y(n)} \quad (14)$$

where α is the forgetting factor that determines the emphasis put by the algorithm on the previous samples of the received data. RLS algorithm is better from the point of view of large array correlation matrix. In case of rapidly varying environments when the tracking of the signals is difficult use of RLS algorithm is recommended to allow for easy updates of the inverse of the correlation matrix. RLS algorithm converges faster than the LMS algorithm and it is not necessary to invert large correlation matrix.

IV. SIMULATION DISCUSSION

In this section, simulations are conducted to evaluate the performance of the proposed adaptive beamforming for the LMS and RLS algorithms in a variety of channel conditions. We assumed an OFDM system perfectly synchronized, with a CP length larger than the channel length with 128 subcarriers (pilot + data), 4-QAM modulation scheme, one desired source and two interferences with equal powers. The desired and interference sources were placed at 70° , 20° , and 120° , respectively. We further assumed normalized channels with different length and real coefficients of [1.0, 0.435, 0.253, 0.1, 0.03], [0.864, 0.435, 0.253, 0.1, 0.05], and [0.9, 0.45, 0.253, 0.1, 0.025] for the desired and interference sources respectively. Pilots were assumed to be distributed uniformly in the OFDM block and the first subcarrier in every cluster was taken as a pilot. The transmitted signals experience the frequency selective, multipath fading channel system specified by 3GPP Long Term Evolution (LTE).

Bit Error Rate (BER) performance is presented for different scenarios are presented in Figs. 4 and 5. In Fig. 4, constant channel is considered; a little bit lower BER is achieved by the post-FFT beamformer scheme. Also, the post-FFT scheme outperforms pre-FFT scheme after Signal-to-Noise Ratio (SNR) of 4 dB. This difference in performance is increased as SNR is increased further. Also the RLS adaptive algorithm outperforms in both pre-FFT and post-FFT schemes.

The post-FFT scheme is superior in performance than the pre-FFT method. The post-FFT method considers the reflected paths of the desired source as the desired signal with a

different phase angle and adjusts the subcarrier weights to combine them constructively. On the other hand, considers the reflected paths of the desired source as interference sources and tries to suppress them (along with actual interferences) by putting nulls at their angles.

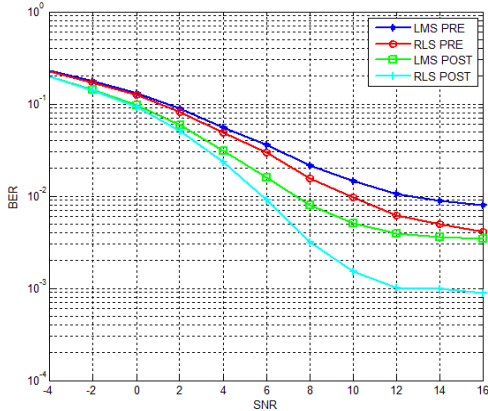

Fig. 4 Performance of pre-FFT and post-FFT beamformers schemes based on LMD and RLS adaptive algorithms under constant channel

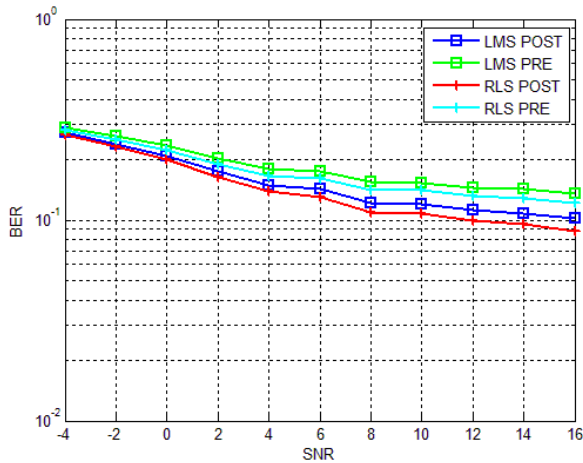

Fig. 5 Performance of pre-FFT and post-FFT beamformers schemes based on LMD and RLS adaptive algorithms under 3GPP LTE channel

RLS algorithm converges faster than the LMS algorithm and it is not necessary to invert large correlation matrix. This is because the convergence of LMS depends on the Eigen value spread of the array correlation matrix.

The effect of multipath fading channel system is specified by 3GPP LTE on the performance of the different schemes and adaptive algorithms in Fig. 5. Constant channel is very straightforward and shows better performance than the other multipath fading channel. Different modulation schemes or power levels will shift the BER curve but will not affect the conclusions made here.

To elaborate on the above points and obtain a clear view of the performance of each method, we performed a comprehensive set of simulations. Constellation map of the

received signals plotted in Figs. 6 and 7 for SNR of 16 dB is in accordance with the BER curves of Figs. 4 and 5. Fig. 6 (a) shows the constellation map of the transmitted signal. Figs. 6 (b)-(e) shows the constellation plot for pre-FFT with LMS, post-FFT with LMS, pre-FFT with RLS, and post-FFT with RLS respectively. It is clear that the result of the post-FFT with RLS algorithm scheme is the best followed by the post-FFT with LMS algorithm then pre-FFT with RLS algorithm and pre-FFT with LMS algorithm respectively. Fig. 7 pictures the constellation plots for different schemes and algorithms under multipath fading channel system specified by 3GPP LTE.

In the rest of this section, the convergence behavior of using LMS and RLS adaptive algorithms in both the pre- and post-FFT beamforming schemes was studied. The optimum weights and the possible performance improvement of the proposed approach for the OFDM system with adaptive array antenna are investigated under the same conditions after about 200 OFDM symbols.

Figs. 8-11 illustrate the convergence performance of all combined schemes under constant channel. Figs. 12-15 illustrate the convergence performance of all combined schemes under 3GPP LTE channel. The best convergence can be achieved using RLS adaptive algorithm comparing to LMS algorithm regardless type of the beamforming scheme pre- or post-FFT and changing channel has not effect convergence performance result.

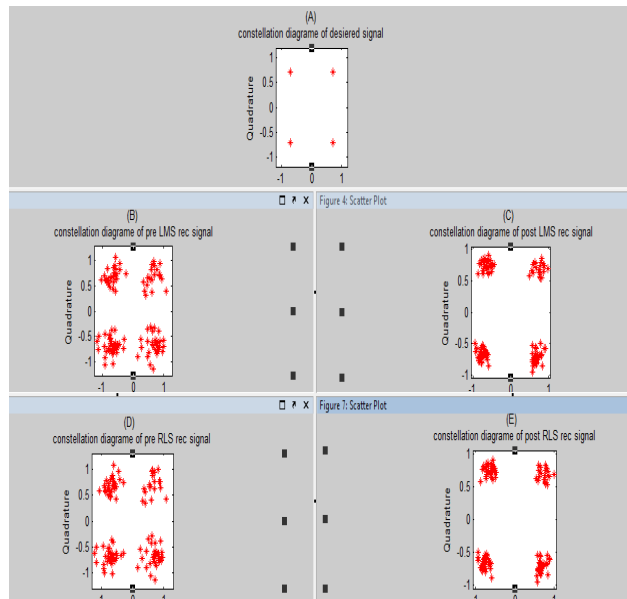

Fig. 6 Constellation maps, under constant channel, of (a) Transmitted signal (b) pre-FFT beamformer with LMS (c) post-FFT beamformer with LMS (d) pre-FFT beamformer with RLS (e) post-FFT beamformer with RLS adaptive algorithm

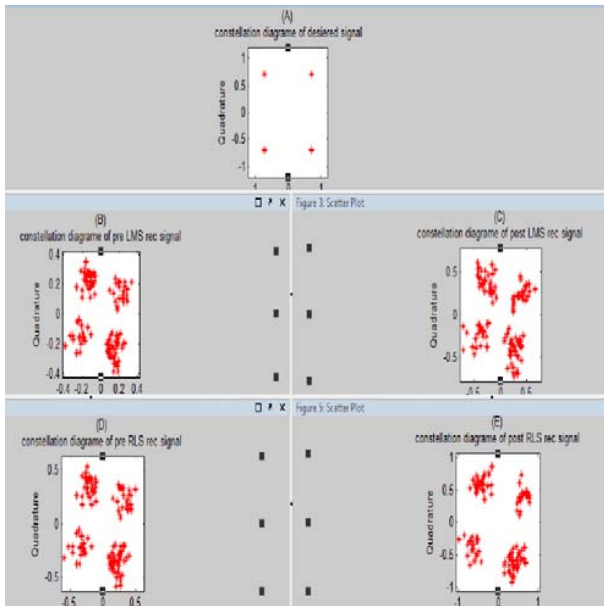

Fig. 7 Constellation maps, under 3GPP LTE channel, of (a) Transmitted signal (b) pre-FFT beamformer with LMS (c) post-FFT beamformer with LMS (d) pre-FFT beamformer with RLS (e) post-FFT beamformer with RLS adaptive algorithm

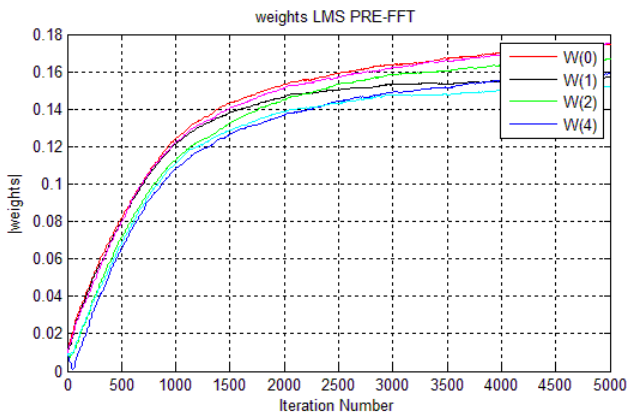

Fig. 8 Convergence of the LMS adaptive algorithm to obtain the optimum weights on the pre-FFT beamformer performance Under constant channel

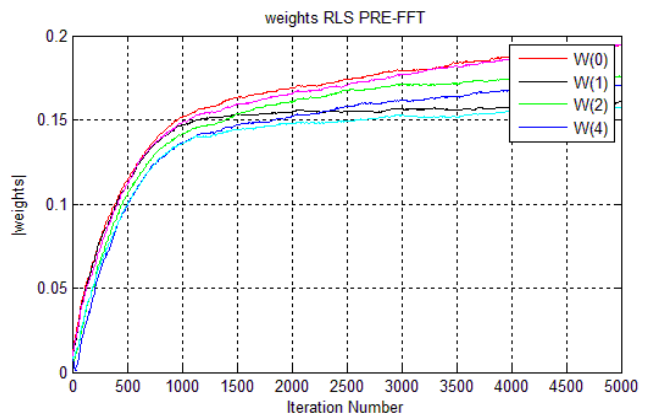

Fig. 9 Convergence of the RLS adaptive algorithm to obtain the optimum weights on the pre-FFT beamformer performance Under constant channel

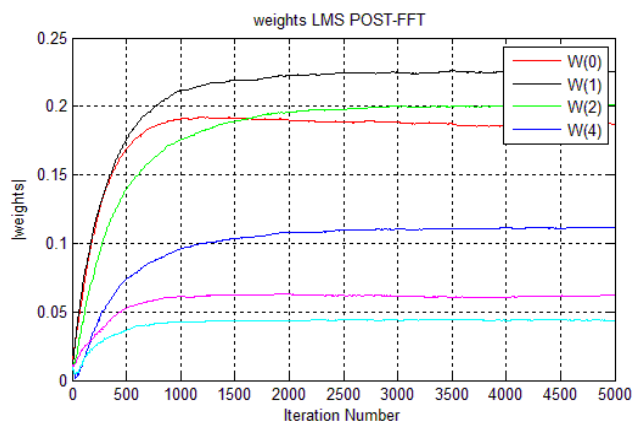

Fig. 10 Convergence of the LMS adaptive algorithm to obtain the optimum weights on the post-FFT beamformer performance Under constant channel

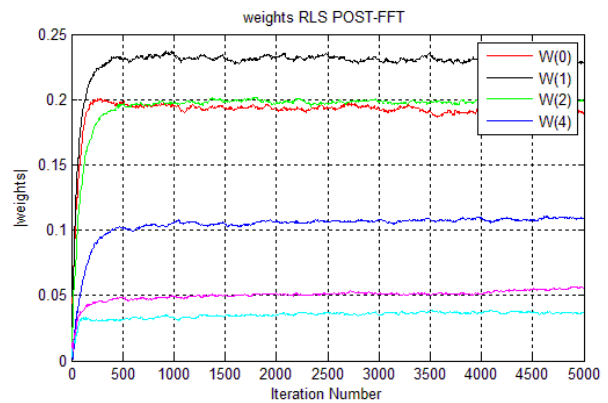

Fig. 11 Convergence of the RLS adaptive algorithm to obtain the optimum weights on the post-FFT beamformer performance Under constant channel

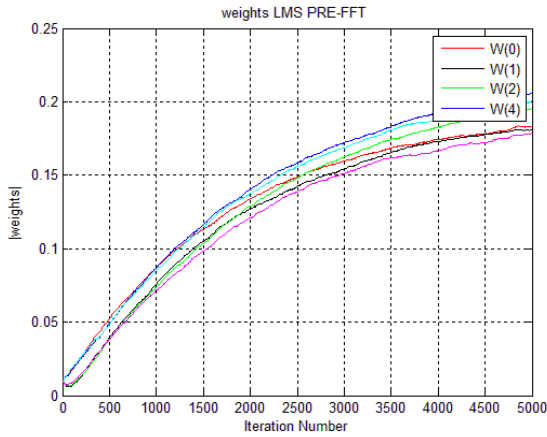

Fig. 12 Convergence of the LMS adaptive algorithm to obtain the optimum weights on the pre-FFT beamformer performance Under multipath fading 3GPP LTE channel

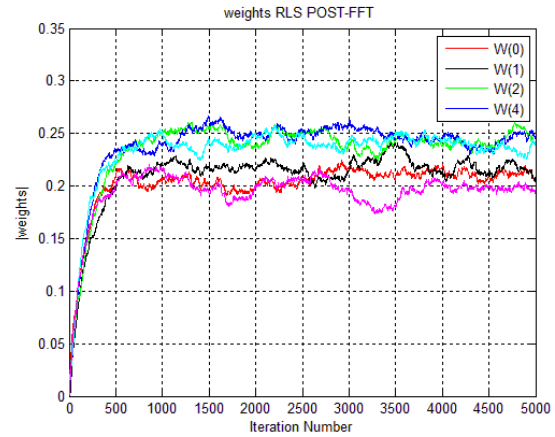

Fig. 15 Convergence of the RLS adaptive algorithm to obtain the optimum weights on the post-FFT beamformer performance Under multipath fading 3GPP LTE channel

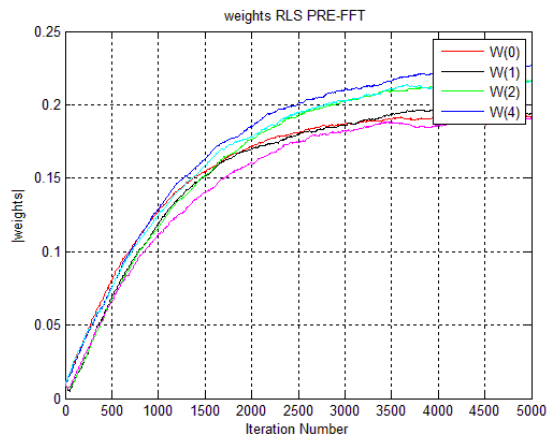

Fig. 13 Convergence of the RLS adaptive algorithm to obtain the optimum weights on the pre-FFT beamformer performance Under multipath fading 3GPP LTE channel

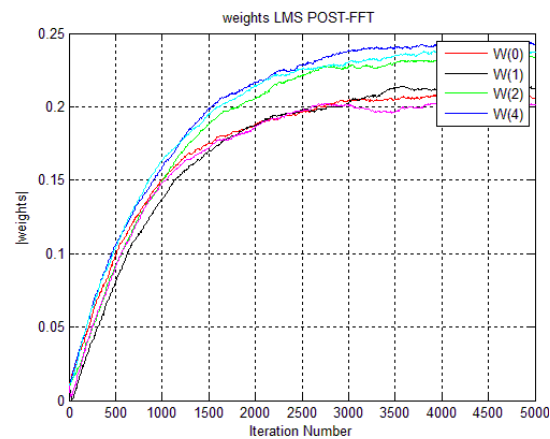

Fig. 14 Convergence of the LMS adaptive algorithm to obtain the optimum weights on the post-FFT beamformer performance Under multipath fading 3GPP LTE channel

V. CONCLUSION

In this paper a pre-FFT and a post-FFT beamformer for OFDM communications have been proposed and analyzed. Least Mean Squares (LMS) and Recursive Least Squares (RLS), are considered as adaptive beamforming algorithms. Moreover, the performance of the system is discussed in multipath fading channel system specified by 3GPP Long Term Evolution (LTE) Release. It was shown that in all scenarios, the post-FFT scheme produces better results pre-FFT beamformer scheme better results in all scenarios, RLS converges faster than LMS adaptive algorithm, the multipath fading channel shows performance degradation than the constant channel, and has no effect on the convergence performance result.

REFERENCES

- [1] C. K. Kim, K. Lee, and Y. S. Cho, "Adaptive Beamforming Algorithm for OFDM Systems with Antenna Arrays", IEEE Trans. on Consumer Electronics, Vol. 64, No.4, pp. 1052-1058, 2000.
- [2] M. Lei, P. Zhang, H. Harada, and H. Wakana, "Adaptive Beamforming Based on Frequency-To-Time Pilot Transform for OFDM", Proc. of 59th IEEE Vehicular Technology Conf., May 2004.
- [3] S. Seydnejad and S. Akhzari "A combined time-frequency domain beamforming method for OFDM systems", 2010 International ITG Workshop on Smart Antennas, IEEE, Feb. 2010.
- [4] M. S. Heakle, M. A. Mangoud, and S. Elnoubi "LMS Beamforming Using Pre and Post-FFT Processing for OFDM Communication Systems," Proc. of the 24th National Radio & Science Conference (NRSC 2007) Mar. 2007.
- [5] A. Udawat1, P. C. Sharma and S. Katiyal "Comparison of Optimization Capabilities of RLS Adaptive Beamforming Algorithm for Smart Antenna Systems," Proc. 5th National Conference; INDIA Com-2011
- [6] H. Matsuoka and H. Shoki, "Comparison of pre-FFT and post-FFT processing adaptive arrays for OFDM systems in presence of co-channel interference," Proc. 14th IEEE International Symposium on Personal, Indoor and Mobile Commun., Sept. 2003.
- [7] Z. Lei and F. P. S. Chin "Post and Pre-FFT Beamforming in an OFDM System," Proc. 59th IEEE Vehicular Technology Conference, May 2004.
- [8] A. M. Mahros, I. Elzahaby, M. M. Tharwat, S. Elnoubi, "Beamforming processing for OFDM communication systems," Proc. of INCT 2012, Istanbul, TURKEY, Oct. 2012.
- [9] A. M. Mahros, M. M. Tharwat, "Implementation of a radio-over-fiber OFDM communication system in the SIMULINK environment,"

International Journal of Advanced Computing, Engineering and Application, vol. 1, issue 3, pp. 123-127, 2012.



Amr M. Mahros was born on February 4th, 1976 in Alexandria, Egypt. In 1998, he obtained his Bachelor of Science (B.Sc.) degree in Communication & Electrophysics Engineering where he was ranked the first in his class. Upon graduation he served in the Egyptian army force for fourteen months. In 1999, he joined the Faculty of Engineering, Alexandria University as a faculty member at Mathematics and Engineering Physics Department. In 2000, he pursued his graduate studies at the Faculty of Engineering, Alexandria University. In 2004, he earned his Master of Science (M.Sc.) degree in engineering physics.

In January 2006, he joined North Carolina State University (NCSU) to pursue his graduate studies under the supervision of Dr. S. M. Bedair leading to his Doctor of Philosophy degree in engineering physics under scientific channel program. During his studies at North Carolina State University, he was an active member of the Egyptian Student Association in North America (ESANA) which overlooks the graduate Egyptian Students in USA and Canada. In January 2007, he was elected as the treasurer of ESANA and in January 2008, he was elected as the social officer. In addition, he is a member of several professional organization and honor societies. In July 2008, Amr returned to Alexandria University, Egypt to pursue his PhD. In July 2009, he joined the Faculty of Engineering, Alexandria University as assistant professor at Mathematics and Engineering Physics Department. In January 2013, he joined the Faculty of Science, King Abdulaziz University (KAU) as assistant professor at Physics Department.