

# Development of Orbital TIG Welding Robot System for the Pipe

Dongho Kim, Sung Choi, Kyowoong Pee, Youngsik Cho, Seungwoo Jeong, Soo-Ho Kim

**Abstract**—This study is about the orbital TIG welding robot system which travels on the guide rail installed on the pipe, and welds and tracks the pipe seam using the LVS (Laser Vision Sensor) joint profile data. The orbital welding robot system consists of the robot, welder, controller, and LVS. Moreover we can define the relationship between welding travel speed and wire feed speed, and we can make the linear equation using the maximum and minimum amount of weld metal. Using the linear equation we can determine the welding travel speed and the wire feed speed accurately corresponding to the area of weld captured by LVS. We applied this orbital TIG welding robot system to the stainless steel or duplex pipe on DSME (Daewoo Shipbuilding and Marine Engineering Co. Ltd.,) shipyard and the result of radiographic test is almost perfect. (Defect rate: 0.033%).

**Keywords**—Adaptive welding, automatic welding, Pipe welding, Orbital welding, Laser vision sensor, LVS, welding D/B.

## I. INTRODUCTION

FOR maintaining global top brand of shipbuilding company, high-added value ship types are needed to be researched and developed with priority of high technique. High-added value ship types like LNGC, offshore plant and passenger ship have large quantities of nonferrous metal such as stainless steel and duplex pipe which demands high-level welding quality. However, the number of high skilled welder is very scarce, and their labor cost is increasing, it provides subsequently process delay for the ship. Besides, manual welding by welder depends on handcraft, hence, working speed is low, and welding quality is not uniform. In automatic pipe welding development of Korea, an example of applying welding trace line and welding condition to the pipe flange using laser vision [1], and the other example of orbital TIG welding applying welding line tracing using LVS [2] have been presented. Also, the example of tracking the robot around the pipe in GMA welding applying arc sensor to welding line tracing has been proposed in [3]. We, DSME robot team has finished to setup rotatable six-axis robot combining LVS to stainless steel and duplex pipe assembly parts in our shipyard, and LVS interfacing and welding database application is included in this research.

This study presents robot system developments. The robot system do trace welding line using LVS running on the rail installed on circumference direction of fixed pipe, while the system welds the v-groove seams of pipes to be in ships and offshore plant.

D. Kim et. al. are with the Daewoo Shipbuilding and Marine Engineering Co. Ltd., Seoul Korea (phone: 822-3667-3810 fax: 822-3667-3819; e-mail: donghokim@dsme.co.kr).

The orbital TIG welding robot system may enable plain welder, who has less enough skill to high quality welding, to weld easily replacing a few high cost TIG welder

## II. SYSTEM CONFIGURATION

### A. System Outline

Orbital TIG-welding robot is largely made up of robot, welding machine, system controller, and LVS. Once LVS obtains the inflection point and surface of gap, mismatch, and remaining area of the joint after welding on pipe joint, the system controller compares welding condition to welding database using shape information, and sends commands to the welding machine. Then the user can monitor welding status with GUI (Graphic User Interface) and UP (User Pendant) immediately. Orbital welding robot system configuration is shown in Fig. 1.

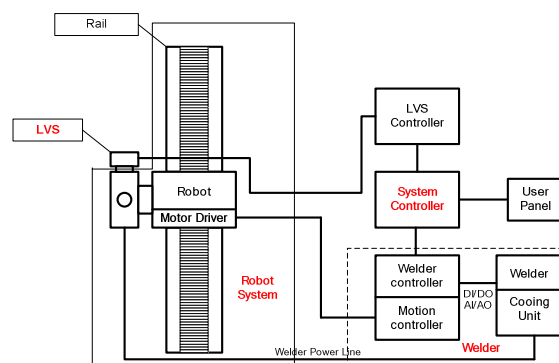

Fig. 1 System configuration of orbital TIG welding robot system

### B. Robot

The mechanical parts of orbital TIG welding robot is composed of robot body, wire feeder, water-cooling torch, robot drive head, torch weaving part, AVC(Automatic Voltage Controller), guide rail, and bunch of cables. The size of robot is 250mm (Horizontal) by 250mm (Vertical). The height of robot body is designed less than 150mm.

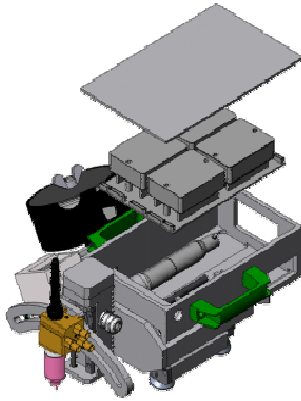

Fig. 2 Inner structure of robot and embedded motor driver

### C. Robot Controller

The robot controller operates the welding robot system. In addition, it has function of welding process control, welding seam control, optimal control of welding condition, welding robot control, welding machine control, and LVS control together.

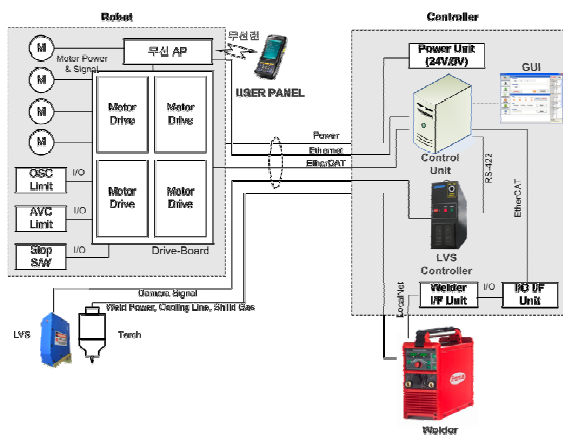

Fig. 3 Structure of robot controller

The robot controller is divided into three modules, which are welding machine controlling module, LVS controlling module, and robot controlling module. The function of three parts of modules is as follow. The welding machine controlling module interfaces the welding machine and the robot through LOCALNET communication protocol made by FRONIUS. [4] LVS controlling module controls the LVS with RS-422 protocol. The robot controlling module controls the robot body and integrates the welding machine controlling module, LVS controlling module and other add-one devices. Along with combining various modules, this module takes a charge of welding robot system management, welding locus creation, optimal welding condition creation and matching with welding database.

### D. LVS (Laser Vision Sensor)

The LVS is made by DSME robot team. This model has

64~146mm field of view and 0.5mm precision on width direction. Also, maximum 30frame/sec of measuring speed is supported. The communication is allowed via RS-232 and RS-422.

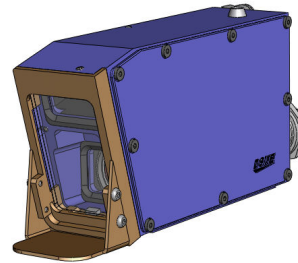

Fig. 4 LVS (Laser Vision Sensor)

### E. Welder

The welding machine is TRANSTIG 4000 which is made by FRONIUS. This is only for TIG welding process, and emits maximum 400 ampere current. Along with communication module, ROB 5000, welding conditioning controls are done with LOCALNET protocol.

## III. DEVELOPMENT OF WELDING PARAMETERS

### A. Basic Welding Parameters

As welding condition is independent with welding position at each pipe section and joint shape of welding object, we developed welding database through experiments selecting optimal welding condition for guaranteeing uniform welding quality.

Orbital TIG welding requires high work experience. Without enough welding skill, it is very hard to reproduce the uniform quality of welding itself. Therefore, experiments coping with various situations are necessary for systemizing and defining the knowledge of the professional welder. In this study, basic welding condition for pipe diameter and welding path is developed with professional welder.

The basic welding condition is initially set to welding condition controlling which are the amount of weld metal and heat input to weld area. The joint shape and the robot position are additionally referenced to welding condition equations for welding condition controlling.

For controlling the amount of weld metal, heat input to weld area, the width of weaving, welding condition control is done selecting current, voltage, robot moving speed, wire feeding speed, and the width of weaving as main parameters. Table I below describes basic welding condition of 6.35mm (thickness) stainless steel pipe.

TABLE I  
BASIC WELDING CONDITION OF STAINLESS STEEL PIPE

Welding parameters	1st Pass	2nd Pass	3rd Pass
Current(A)	110	140	140
Welding Voltage(V)	8.1	8.7	9.1
Travel Speed(mm/s)	1.0	1.0	1.0
Wire Feed Speed(mm/s)	11.0	13.0	20.0
Width(mm)	4.0	5.5	8.0
Weaving Dwell(s)	0.7	0.7	0.6
Weaving(s)	0.4	0.5	0.65

### B. Automatic Welding Procedure

Automatic procedure of orbital TIG welding is done with five steps using joint shape of welding object and robot position of each pipe section.

The first step is selecting the pipe. Determining the number of welding path at the second step, the area information is extracted turning the robot around the pipe circumference. Once welding condition based on welding speed and wire feeding speed corresponding with joint surface is chosen automatically in third step, then the user determines AVC(Auto Voltage Control: same as welding voltage) value manually with GUI or UP, and manipulates wire feeding position. This is resulted from proper AVC value is hard to be regulated with surroundings (electric grounding, pipe materials). At the fifth step, welding seam line is traced obtaining joint shape in real time while welding, and weaving width is determined measuring the groove width. Eventually, the amount of weld metal is calculated from the equation of the amount of weld metal applying cross sectional surface area.

### C. Determine Amount of Weld Metal for Each Welding Pass

$S_{weld}$  (welding area) corresponding to the path could be obtained with  $S_{joint}$  (sensed joint area while welding). Equations concerning with this study is inferred by experiments and theory. Table II presents the amount of weld metal of 16"(thickness: 4.78mm) and 24"(thickness: 6.35mm).

TABLE II  
METHOD FOR MULTI PASS WELDING

Pipe	Pass	Area of Weld : $S_{weld}$ (mm <sup>2</sup> )
16" 4.78t	1P Final	$S_{joint}^{*1)+10}$
	1P Fill	$0.9 \times S_{joint}$
	2P Final	11
24" 6.35t	1P Fill	$0.4 \times S_{joint}$
	2P Fill	$0.7 \times S_{joint}$
	3P Final	$S_{joint} - S_{max}^{*2)+7}$

\*1)  $S_{joint}$  : Sensed joint area while welding

\*2)  $S_{joint} - S_{max}$  : Sensed joint area while welding of 2nd Pass-Max area of weld

### D. Control Amount of Weld Metal

The semi-automatic orbital welding machine has a defect in control of the amount of weld metal. The user response of speed and the user posture give limitation of sensing the surface area of joint and manipulating the amount of weld metal. The semi-automatic machine also shows non-uniform bead shape by initial welding condition.

In this study, the robot system supplies the amount of weld

metal to welding joint adjusting welding speed and wire feeding speed using cross sectional surface area through LVS. Even cross sectional area is not uniform in inside joint, flat quality of welding can be produced expanding maximum and minimum amount of weld metal adjusting two parameters simultaneously which are welding speed or wire feeding speed over cross sectional surface area comparing one parameter, welding speed or wire feeding speed.

Generally, adjusting only one parameter is often utilized. It is due to the face that by both of two parameters is more difficult than by only one parameter to carry out controlling the amount of weld metal. In this study, equations concerning with two parameters are derived taking advantage of maximum and minimum amount of weld metal.

For automatic control of the amount of weld metal, welding speed over joint surface area of welding object and wire feeding speed of it are necessary. Equations derived as following procedure.

Considering the amount of weld metal based on joint cross sectional surface area, basic welding parameters are required. Note that both maximum and minimum welding speed are determined based on welding speed and wire feeding speed of basic welding condition.

Parameters for automatic control mode of the amount of weld metal are  $S_{weld}$  (welding area),  $S_{wire}$  (cross-section area of wire),  $V_{wire}$  (wire feeding speed).

Equation (1) describes the maximum and minimum welding speed, and (2) is about maximum and minimum wire feeding speed.

$$\begin{aligned} V_{trv}[\max] &= V_{trv}[\text{ref.}] + \alpha \\ V_{trv}[\min] &= V_{trv}[\text{ref.}] - \alpha \end{aligned} \quad (1)$$

where  $\alpha$  is manipulating range of welding speed. The unit of speed is (mm/s).

$$\begin{aligned} V_{wire}[\max] &= V_{wire}[\text{ref.}] + \beta \\ V_{wire}[\min] &= V_{wire}[\text{ref.}] - \beta \end{aligned} \quad (2)$$

where  $\beta$  is manipulating range of wire feeding speed. The unit of speed is (mm/s).

Note that the product of welding surface and welding speed is equal to the product of wire feeding speed and wire cross sectional area. Physically, the product means [volume of weld metal/sec], whose unit is mm<sup>3</sup>/sec.

$$S_{weld} \times V_{trv} = S_{wire} \times V_{wire} \quad (3)$$

Arranging to (3), it turns out  $S_{weld}$  is the function of welding speed and wire feeding speed.

$$S_{weld} = \frac{V_{wire}}{V_{trv}} \times S_{wire} \quad (4)$$

where  $S_{wire}$  is constant.

Applying the definition of maximum and minimum amount of weld metal to (4), linear equations, which are function of the area of weld metal, welding speed, wire feeding speed, are produced. The function is eventually for wire speed and wire feeding speed over desired amount of weld metal.

$$S_{weld}[\max] = \frac{V_{wire}[\max]}{V_{trv}[\min]} \times S_{wire} \tag{5}$$

$$S_{weld}[\min] = \frac{V_{wire}[\min]}{V_{trv}[\max]} \times S_{wire} \tag{6}$$

where  $S_{weld}[\max]$  is maximum welding area

$S_{weld}[\min]$  is minimum welding area

Using (5) and (6), the linear equation (7) is derived as shown in Fig. 5.

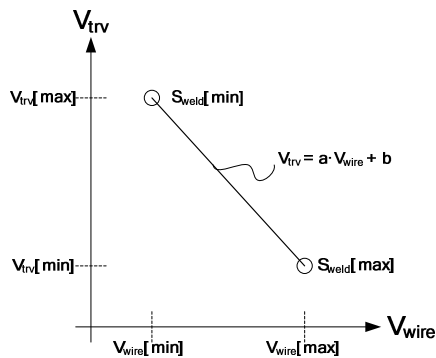

Fig. 5 Derivation of welding speed and wire feed speed using Min/Max area of weld

$$V_{trv} = a \cdot V_{wire} + b \tag{7}$$

where

$$a = \frac{V_{trv}[\min] - V_{trv}[\max]}{V_{wire}[\max] - V_{wire}[\min]}$$

$$b = -\frac{V_{trv}[\min] - V_{trv}[\max]}{V_{wire}[\max] - V_{wire}[\min]} \times V_{wire}[\min] + V_{trv}[\max]$$

Substituting (7) with (3), welding speed and wire feeding speed are derived.

The final equation for the area of weld metal to welding speed is (8), and the area of weld metal to wire feeding speed equation is written on (9);

$$V_{trv} = \frac{-b \times S_{wire}}{a \times S_{weld} - S_{wire}} \tag{8}$$

$$V_{wire} = \frac{b \times S_{weld}}{-a \times S_{weld} + S_{wire}} \tag{9}$$

### E. Welding Test

For conducting automatic welding of orbital welding robot, outer diameter 16"(400A) and outer diameter 24"(600A) pipe, whose material are identically stainless steel 316, are tried to test for verifying welding robot, LVS, control algorithm. In this case, the thickness of 16"(400A) pipe is 4.78mm, and the thickness of 24"(600A) pipe is 6.35mm. Both pipe have bevel angle, 70 degree, and are welded to manual mode in root path experiment. Shielding gas is purely 100% AR gas. Wire is AWS ER316L product, which is diameter, 0.9mm.

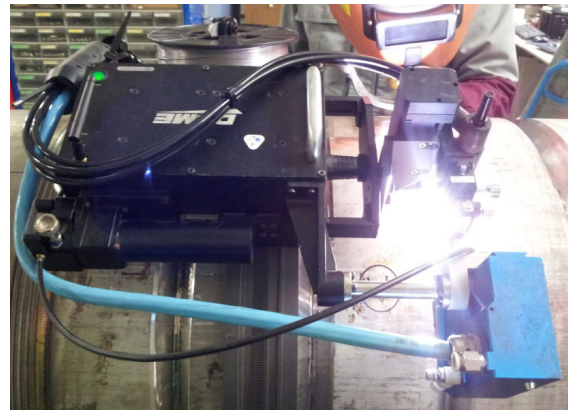

Fig. 6 Welding test

TABLE III  
SAMPLE WELDING CONDITION OF 600A PIPE

Welding Parameter		Case of 1 Pass
Current (A)		100~110(Auto)
AVC(V)		Auto (after Manually Fixed)
Travel(mm/s)		0.9~1.2(Auto)
Wire Feed(mm/s)		11~16(Auto)
Weld area	Min(mm <sup>2</sup> )	5.8
	Max(mm <sup>2</sup> )	11.3
Weave	Width(mm)	Auto (depend on the Groove width)
	Dwell(s)	0.7
	Exc.(s)	0.4



Fig. 7 Welding quality of manual welding vs. automatic welding

#### IV. APPLICATION TO SHIP YARD

##### A. Application for Stainless Steel

The field test of robot in DSME shipyard has been tried during one month. Materials to have been tested is stainless steel 304 and 316(4.5T~12.7T). All thirty pipes are tested, and defective rate is 0.033% in those. It is lower defective compared to average defective proportion, 0.5%. Moreover, productivity is improved to 30%.



Fig. 8 Stainless steel pipe welding in DSME shipyard

##### B. Application for Duplex Stainless Steel

The duplex steel also has been tested in DSME shipyard. However, joint welding, whose thickness is over 30mm, was carried out. 30T-welding has many passes (minimum 40 PASS); hence, control of heat input to weld area is very important. Thus, welding has been accomplished maintaining the temperature, 150 Celsius degree between passes.

#### V. CONCLUSION

In stainless steel welding requiring high skilled welder, We, DSME robot team developed automatic welding robot installed on the rail which is tangential direction to the circular pipe.

Using LVS, obtaining cross sectional surface area of pipe joint, uniform welding quality was guaranteed controlling welding speed and wire feeding speed with the acquired surface area.

Furthermore, the database for stainless steel and duplex pipe was created and successfully applied to our shipyard.

Apart from stainless steel and duplex steel materials, carbon steel, titanium, hastelloy, and etc. might be expected to the automatic welding system developed in this study, and welding condition researched in this study will be hopefully provided in those materials.



Fig. 9 Before and after welding quality of Duplex steel

#### REFERENCES

- [1] Y. H. Kang, S. G. Lee, H. J. Song, S. J. Na, T. I. Cha, J. Y. Park : A study on the development of automatic welding system for pipe welding, 2001 Annual Fall Meeting of KWS, 173-176 (in Korean).
- [2] M. G. Kang, J. H. Kim, Y. J. Park, G. J. Woo : Laser Vision System for Automatic Seam Tracking of Stainless Steel Pipe Welding Machine, International Conference on Control, Automation and Systems 2007.
- [3] K. Y. Bae, J. H. Lee, S. W. Chung : A Study On control of weld pool and torch position in GMA welding of steel pipe by using sensing systems, Journal of KWS, Vol. 16, No 5, October, 1998, 463-477 (in Korean).
- [4] Fronius user manual for TransTig4000 and Rob5000.