

Symbolic Analysis of Input Impedance of CMOS Floating Active Inductors with Application in Fully Differential Bandpass Amplifier

Kittipong Tripetch

Abstract—This paper proposes a study of input impedance of 2 types of CMOS active inductors. It derives 2 input impedance formulas. The first formula is the input impedance of the grounded active inductor. The second formula is the input impedance of the floating active inductor. After that, these formulas can be used to simulate magnitude and phase response of input impedance as a function of current consumption with MATLAB. Common mode rejection ratio (CMRR) of the fully differential bandpass amplifier is derived based on superposition principle. CMRR as a function of input frequency is plotted as a function of current consumption.

Keywords—Grounded active inductor, floating active inductor, Fully differential bandpass amplifier.

I. INTRODUCTION

ACTIVE inductor implemented by CMOS technology was proposed since 1996 [1]. Usually, its inductance value is a function of current consumption and load capacitance. The more current consumption, the lower the inductance value. After that, there is considerable interest in quality factor (Q) enhancing technique of a grounded active inductor which was proposed since 2000 [2], because of low Q value and large silicon area of spiral inductor. By utilizing higher gain in the amplifier stage of the gyrator loop, the quality factor of a grounded active inductor can be improved to 12,000.

Another 2 papers on improving quality factor of a grounded active inductor was proposed in [3], [4]. The first circuit was based on the amplifier stage of the NMOS cascade transconductor cascade with feedback stage common source transconductor. It has an additional feedback resistor between the output of amplifier stage of cascade transconductor and input of feedback stage of common source transconductor. This circuit consumed less than 8 mW at 5.7nH at 1.55 GHz and it has Q of 70. The second circuit was based on amplifier stage of NMOS common source transconductor cascade with feedback stage of NMOS common source transconductor. It has an additional feedback resistor between the output of amplifier stage of NMOS common source transconductor and input of feedback stage of common source transconductor. It also has additional capacitance at the output node of the amplifier stage of NMOS common source transconductor as a design variable.

Kittipong Tripetch is with division of electronic and telecommunication engineering, Faculty of Engineering and Architecture, Rajamangala University of Technology Suvarnabhumi, Nonthaburi Campus, Thailand (e-mail: kittipong_t@rmutsb.ac.th).

Floating active inductor implemented in CMOS technology was first proposed since 2000 [5]. They designed differential oscillator at 1.2 GHz by consuming current approximately 220 microamperes. Another floating active inductor implemented in CMOS technology was proposed since 2006 [6]. They designed VCO with wide tuning range (143%) with 6-28 mW of power consumption at 0.5-3 GHz tuning range.

This paper organized as follows. Section II describes the first proposed circuit topology and derives the formula of the input impedance of the proposed circuit and its simulation results. Section III describes the second proposed circuit topology and derives the formula of the input impedance of the proposed circuit and its simulation results. The conclusion is given in Section IV.

II. THE PROPOSED GROUNDED ACTIVE INDUCTOR

The first proposed circuit is grounded active inductor based on amplifier stage of PMOS common source transconductor with feedback stage of PMOS common source transconductor. It has an additional feedback resistor between the output of amplifier stage of PMOS common source transconductor and input of feedback stage of PMOS common source transconductor. It also has additional capacitance at the output node of amplifier stage of PMOS common source transconductor. The complete schematic is shown in Fig. 1.

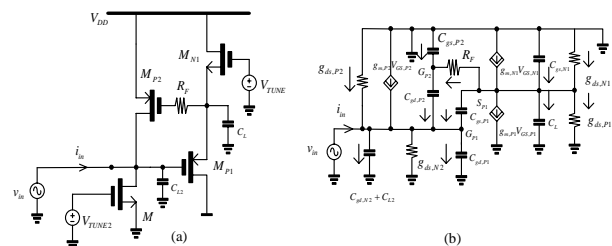

Fig. 1 proposed grounded active inductor (a) transistor level (b) small signal equivalent of 1a

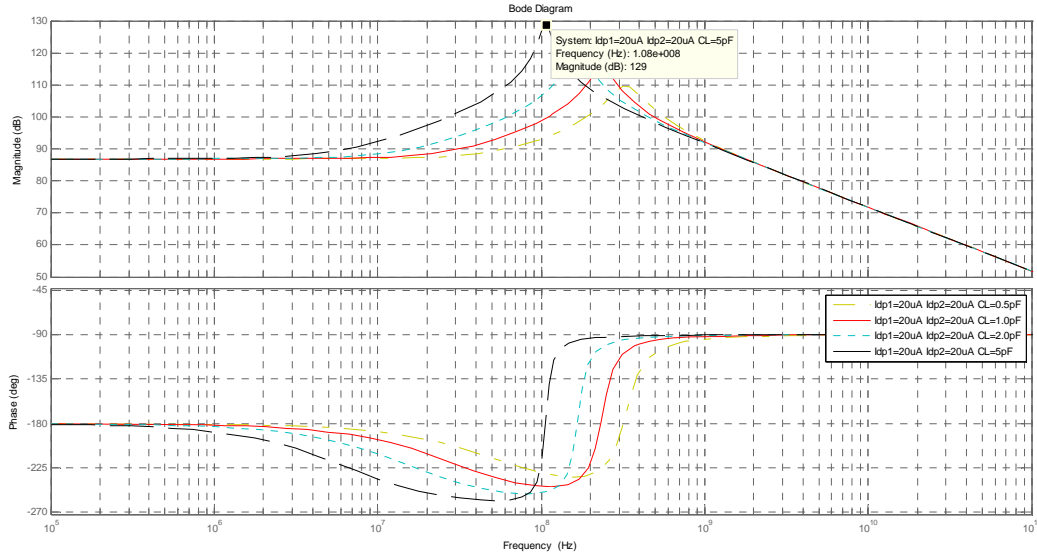

Fig. 2 Typical magnitude and phase response of input impedance of Fig. 1 (b) (drain source conductances are not included)

The input impedance of Fig. 1 is derived as follows equations

$$z_{in} = \frac{(s^2 c_2 + s c_1 + c_o)}{s^4 f_4 + s^3 f_3 + s^2 f_2 + s f_1 + f_o}$$

$$f_4 = a_2 c_2 - d_2 b_2$$

$$f_3 = (a_2 c_1 + c_2 a_1) - (d_2 b_1 + b_2 d_1)$$

$$f_2 = (a_2 c_o + c_2 a_o + a_1 c_1) - (d_2 b_o + b_2 d_o + d_1 b_1)$$

$$f_1 = (a_1 c_o + c_1 a_o) - (d_1 b_o + b_1 d_o)$$

$$f_o = a_o c_o - d_o b_o$$

$$a_2 = (C_{gs,P1} R_F) C_{gd,P2}$$

$$a_1 = \left(\begin{array}{l} C_{gd,P2} + C_{gs,P1} + C_{gd,P1} + C_{gd,N2} \\ + C_{L2} + (C_{gs,P1} R_F) g_{mP2} - g_{mP1} R_F C_{gd,P2} \end{array} \right)$$

$$a_o = -(g_{m,P1} R_F) g_{mP2} + g_{dsN2} + g_{dsP2}$$

$$b_2 = (C_{gs,P1} + C_{gs,N1} + C_L) R_F C_{gd,P2}$$

$$b_1 = C_{gd,P2} (1 + (-g_{mP1} + g_{mN1} + g_{dsP1} + g_{dsN1}) R_F) + (C_{gs,P1} + C_{gs,N1} + C_L) R_F g_{mP2} + C_{gs,P1}$$

$$b_o = (1 + (-g_{mP1} + g_{mN1} + g_{dsP1} + g_{dsN1}) R_F) g_{mP2}$$

$$c_2 = ((C_{gs,P1} + C_{gs,N1} + C_L) R_F (C_{gd,P2} + C_{gs,P2}))$$

$$c_1 = \left(\begin{array}{l} (C_{gs,P1} + C_{gs,N1} + C_L) \\ + (1 + (-g_{m,P1} + g_{m,N1} + g_{dsP1} + g_{dsN1}) R_F) (C_{gd,P2} + C_{gs,P2}) \end{array} \right) \quad (3)$$

$$c_o = (-g_{m,P1} + g_{m,N1} + g_{dsP1} + g_{dsN1})$$

$$d_2 = (C_{gs,P1} R_F) (C_{gd,P2} + C_{gs,P2})$$

$$(1) \quad d_1 = (C_{gd,P2} + C_{gs,P1} - (C_{gd,P2} + C_{gs,P2}) (g_{mP1} R_F))$$

$$d_o = -g_{mP1}$$

All coefficients in (1)-(3) are a function of parasitic capacitances, transconductances and drain to source conductances of the transistors and feedback resistor. Subscripts of the parameters indicate the name of the transistors.

The parameters used in the simulation with MATLAB are as follows. IdP1=IdN1=IdP2=IdN2=20uA, Rf=1kohm The level1 0.5um CMOS process parameters which appeared in [8] are listed following lambda=0.1, lambda=0.2, VtoN=0.7, VtoP=-0.8, UON=460, UOP=115, Tox=9.5e-9.

(2) Typical magnitude and phase response of grounded active inductor without drain to source conductance in Fig. 1 is shown in Fig. 2. It can be seen that phase response is not 90 or minus 270 degrees at all input frequencies. Thus, it can be seen that we use drain current only 20uA because it is the minimum current which aspect ratio of Mp1 can be designed to be larger than 1. And if we increased capacitive load from 0.5pF to 5pF, the resonance frequency of the input impedance of this circuit can be decreased from 330 MHz, 238MHz, 168MHz and 106 MHz, respectively.

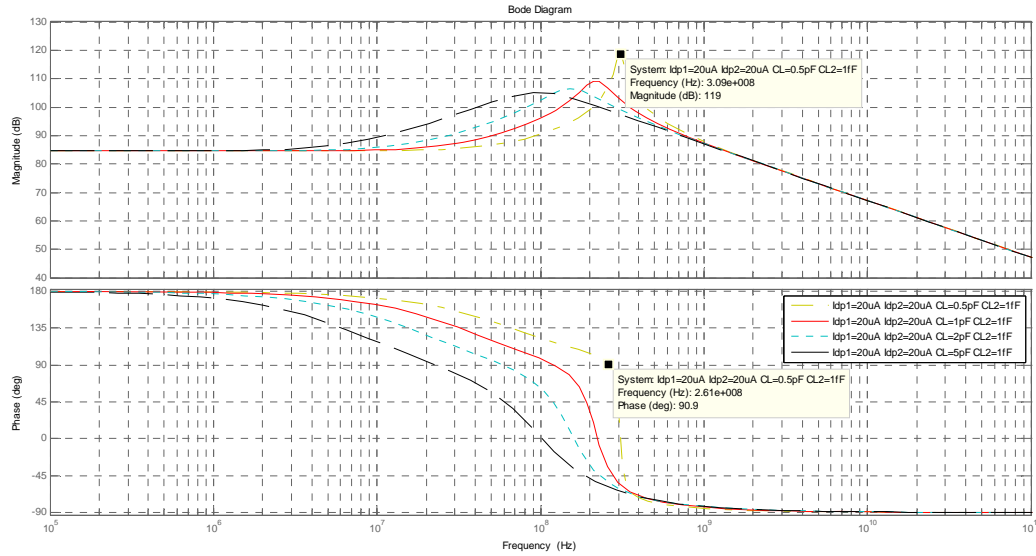

Fig. 3 Typical magnitude and phase response of the input impedance of Fig. 1 (b) (drain to source conductances are included)

Phase response can be seen from Fig. 2 as follows, for Capacitive load of 0.5pF, phase response reaches minus 270 degrees. For capacitive load of 1pF, phase response could not reach minus 270 degrees. For capacitive load of 2pF, phase response could not reach minus 270 degrees. For capacitive load of 5pF, phase response could not reach minus 270 degrees. It can be concluded from this graph that at current of 20uA, input impedance of the circuit behaves like inductance as we increase the capacitive load. After input frequencies pass resonance frequency its impedance can become more capacitive.

The design parameters of circuit in Fig. 1 (b) which drain sourced conductances are not included which are listed as following.

$$R_f = \text{feedback resistor} = 1\text{kohm}$$

$$C_{gsp1} = \text{gate to source capacitance of a transistor Mp1} = 1.97 \times 10^{-15} \text{ Farad}$$

$$C_{gsp2} = \text{gate to source capacitance of transistor Mp2} = 1.43 \times 10^{-14} \text{ Farad}$$

$$C_{gsn1} = \text{gate to source capacitance of transistor Mn1} = 2.28 \times 10^{-15} \text{ Farad}$$

$$C_{gdp1} = \text{gate to drain capacitance of transistor Mp1} = 5.37 \times 10^{-16} \text{ Farad}$$

$$C_{gdp2} = \text{gate to drain capacitance of transistor Mp2} = 3.91 \times 10^{-15} \text{ Farad}$$

$$\text{Aspect ratio of Mn1} = 3.80$$

$$\text{Aspect ratio of Mp1} = 3.29$$

$$\text{Aspect ratio of Mp2} = 23.95$$

Gate voltage of Mp1 = 2.5 Volt, Gate voltage of Mp2 = 4 Volt

The gate voltage of Mn1 = 5 Volt, Supply voltage = 5 Volt

Vsbp1 = source bulk voltage of Mp1 = -1 Volt

Vsbp2 = source bulk voltage of Mp2 = 0 Volt

Vsbn1 = source bulk voltage of Mn1 = 4 Volt

Typical magnitude and phase response of a grounded active inductor which includes drain to source conductance in Fig. 1 is shown in Fig. 3. It can be seen that phase response is 90 degrees only at one point of frequency. This observation can be seen in Fig. 3 as follows. At drain current of 20uA and capacitive load varies from 0.5pF to 5pF, the resonance frequency of the input impedance of this circuit can be decreased from 313 MHz, 217MHz, 154MHz and 98 MHz, respectively.

Phase response can be seen from Fig. 3 as follows, for capacitive load of 0.5pF, phase response reaches 90 degrees at 261 MHz. For capacitive load of 1pF, phase response reaches 90 degrees at 121 MHz. For capacitive load of 2pF, phase response reaches 90 degrees at 58.6 MHz. For capacitive load of 5pF, phase response reaches 90 degrees at 23.2 MHz.

III. THE PROPOSED FLOATING ACTIVE INDUCTOR

The second circuit is floating active inductor based on 2 stages of the transconductor cascade with 2 stages of transconductor. The 2 stage transconductor composed of common gate transconductor as the first stage and common drain transconductor as the second stage. The complete schematic is shown in Fig. 4.

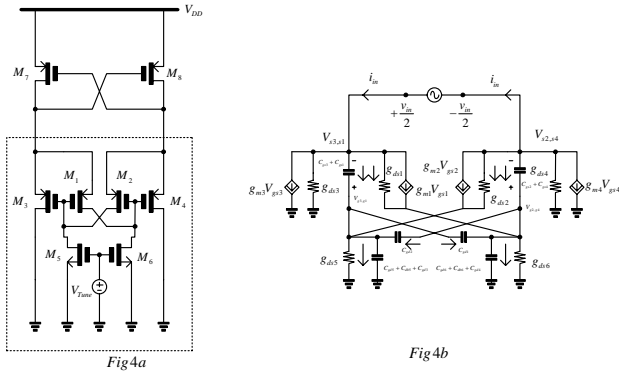

Fig. 4 Proposed floating active inductors (FAI) (a) PMOS cross coupled oscillator FAI (b) small signal equivalent circuit of FAI

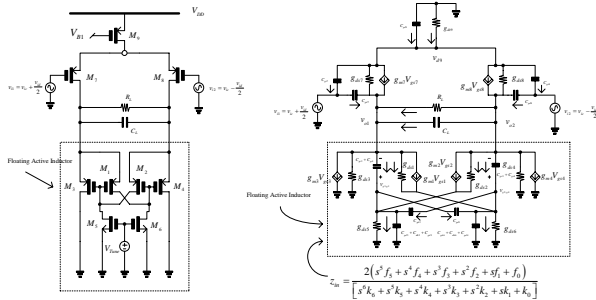

Fig. 5 Proposed floating active inductor (a) fully differential bandpass amplifier (b) small signal equivalent circuit of a fully differential bandpass amplifier

The input impedance of a floating active inductor in Fig. 4 (b) can be derived as follows equations.

$$z_{in} = \frac{v_{in}}{i_{in}} = \frac{2(s^5 f_5 + s^4 f_4 + s^3 f_3 + s^2 f_2 + s f_1 + f_0)}{[s^6 k_6 + s^5 k_5 + s^4 k_4 + s^3 k_3 + s^2 k_2 + s k_1 + k_0]}$$

$$k_6 = h_5 (C_{gs3} + C_{gs1}) + i_5 (C_{gs3} + C_{gs1})$$

$$k_5 = g_{ds1} g_5 - (h_5 g_x - h_4 (C_{gs3} + C_{gs1})) - (i_5 (g_{m3} + g_{m1}) - i_4 (C_{gs3} + C_{gs1}))$$

$$k_4 = g_{ds1} g_4 - (h_4 g_x - h_3 (C_{gs3} + C_{gs1})) - (i_4 (g_{m3} + g_{m1}) - i_3 (C_{gs3} + C_{gs1}))$$

$$k_3 = \begin{pmatrix} g_{ds1} g_3 - (h_3 g_x - h_2 (C_{gs3} + C_{gs1})) \\ -(i_3 (g_{m3} + g_{m1}) - i_2 (C_{gs3} + C_{gs1})) \end{pmatrix} \quad (4)$$

$$k_2 = \begin{pmatrix} g_{ds1} g_2 - (h_2 g_x - h_1 (C_{gs3} + C_{gs1})) \\ -(i_2 (g_{m3} + g_{m1}) - i_1 (C_{gs3} + C_{gs1})) \end{pmatrix}$$

$$k_1 = \begin{pmatrix} g_{ds1} g_1 - (h_1 g_x - h_0 (C_{gs3} + C_{gs1})) \\ -(i_1 (g_{m3} + g_{m1}) - i_0 (C_{gs3} + C_{gs1})) \end{pmatrix}$$

$$k_0 = (g_{ds1} g_0 - h_0 g_x - i_0 (g_{m3} + g_{m1}))$$

$$f_5 = b_2 d_3, f_4 = (b_2 d_2 + b_1 d_3), f_3 = (b_0 d_3 + b_1 d_2 + b_2 d_1)$$

$$f_2 = (b_2 d_0 + b_1 d_1 + b_0 d_2), f_1 = (b_1 d_0 + b_0 d_1), f_0 = b_0 d_0$$

$$g_5 = a_2 d_3, g_4 = (a_1 d_3 + a_2 d_2), g_3 = (d_3 a_0 + d_2 a_1 + d_1 a_2)$$

$$g_2 = (a_2 d_0 + a_1 d_1 + a_0 d_2), g_1 = (a_1 d_0 + a_0 d_1), g_0 = a_0 d_0$$

$$h_5 = b_2 d_3, h_4 = (b_2 d_2 + b_1 d_3), h_3 = (b_2 d_1 + b_1 d_2 + b_0 d_3)$$

$$h_2 = (b_2 d_0 + b_1 d_1 + b_0 d_2), h_1 = (b_1 d_0 + b_0 d_1), h_0 = b_0 d_0$$

$$i_5 = c_3 b_2, i_4 = (c_3 b_1 + c_2 b_2), i_3 = (c_3 b_0 + c_2 b_1 + c_1 b_2)$$

$$i_2 = (c_2 b_0 + c_1 b_1), i_1 = (c_1 b_0 + c_0 b_1), i_0 = c_0 b_0$$

$$c_3 = (a_2 C_2 - b_2 (C_{gs2} + C_{gs4}))$$

$$c_2 = ((a_2 (g_{ds6} + g_{ds1}) + a_1 C_2) - ((b_2) (g_{m1} - g_{ds1}) + b_1 (C_{gs2} + C_{gs4})))$$

$$c_1 = ((a_1 (g_{ds6} + g_{ds1}) + C_2 a_0) - (b_0 (C_{gs2} + C_{gs4}) + b_1 (g_{m1} - g_{ds1})))$$

$$c_0 = (a_0 (g_{ds6} + g_{ds1}) - b_0 (g_{m1} - g_{ds1})) \quad (6)$$

$$d_3 = b_2 (C_{gd1} + C_{gd2})$$

$$d_2 = (b_2 g_{m1} + b_1 (C_{gd1} + C_{gd2}))$$

$$d_1 = (b_1 g_{m1} + b_0 (C_{gd1} + C_{gd2}))$$

$$d_0 = b_0 g_{m1}$$

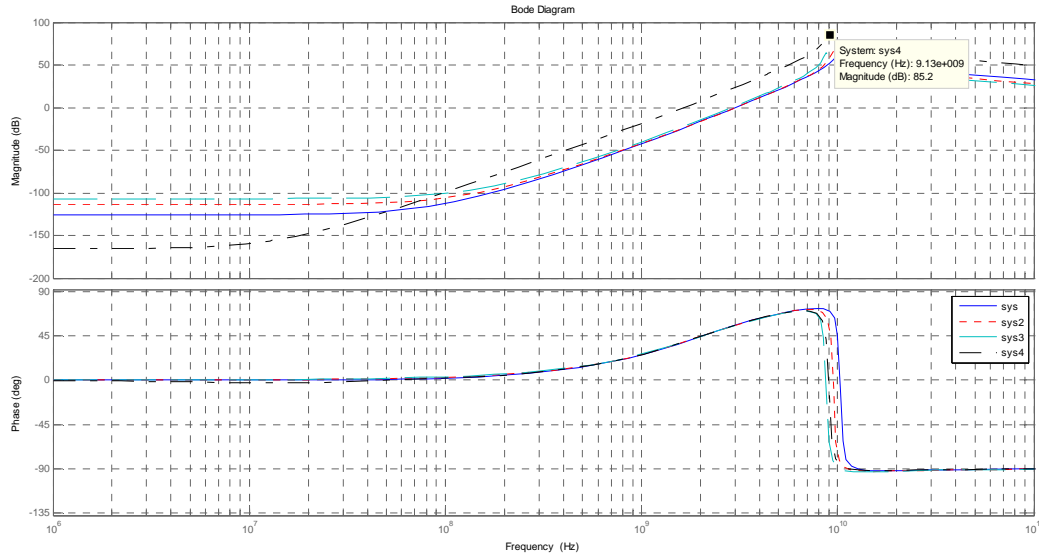

Fig. 6 Typical Magnitude and phase response of input impedance of Fig. 4 (b)

$$\begin{aligned}
 a_2 &= [(C_{gs3} + C_{gs1})(C_{gd1} + C_{gd2}) - (C_{gs2} + C_{gs4})C_1] \\
 a_1 &= \begin{bmatrix} (C_{gs3} + C_{gs1})g_{m1} + (C_{gd1} + C_{gd2})(g_{m2} - g_{ds2}) \\ -[(C_{gs2} + C_{gs4})(g_{ds2} + g_{ds5}) + C_1(g_{m1} - g_{ds1})] \end{bmatrix} \\
 a_0 &= [(g_{m2} - g_{ds2})g_{m1} - (g_{m1} - g_{ds1})(g_{ds2} + g_{ds5})] \\
 b_2 &= [(C_{gd2} + C_{gd1})(C_{gd1} + C_{gd2}) - C_2C_1] \\
 b_1 &= \begin{bmatrix} [(C_{gd2} + C_{gd1})g_{m1} + (C_{gd1} + C_{gd2})g_{m2}] \\ -[C_2(g_{ds2} + g_{ds5}) + C_1(g_{ds6} + g_{ds1})] \end{bmatrix} \\
 b_0 &= [g_{m2}g_{m1} - (g_{ds6} + g_{ds1})(g_{ds2} + g_{ds5})] \\
 C_1 &= C_{gs3} + C_{gs1} + C_{gd2} + C_{gd1} + C_{gd5} + C_{ds5} + C_{gd3} \\
 C_2 &= C_{gd6} + C_{ds6} + C_{gd4} + C_{gs2} + C_{gs4} + C_{gd1} + C_{gd2} \\
 g_x &= g_{m3} + g_{m1} - (g_{ds3} + g_{ds1})
 \end{aligned} \quad (7)$$

All coefficients in (4)-(7) are a function of parasitic capacitances, transconductances and drain to source conductances of the transistors and feedback resistor. Subscript of the parameters indicates the name of the transistors.

The parameters used in the simulation with MATLAB are as follows. $I_{dp1}=I_{dp2}=I_{dp3}=I_{dp4}=1\mu A, 10\mu A, 20\mu A, 30\mu A$.

$I_{dn5}=I_{dn6}=1\mu A, 10\mu A, 20\mu A, 30\mu A$, respectively. The level1 0.5um CMOS process parameters which appeared in [8] are as follows $\lambda_{nN}=0.1, \lambda_{nDP}=0.2, V_{toN}=0.7, V_{toP}=-0.8, U_{ON}=460, U_{OP}=115, T_{ox}=9.5e-9$. For graph in Fig. 6, we used a minimum length to be 1 micron.

Typical magnitude and phase response of the floating active inductor is shown in Fig. 6. Fig. 6 can be described as follows. For sys4, which is shown in black dashed dotted line, the current is designed to be 1 microampere. The magnitude response arises from minus 166 dB at 1MHz until it reaches resonance frequency 9.13 GHz at 85.2 dB. The phase response for this current consumption starts from 0 degree. It rises slowly at 100 MHz until it reaches 69.5 degrees at 7.4 GHz.

After that, it falls dramatically to minus 90.6 degrees at 11.8 GHz.

For sys, which is shown in blue solid line, the current is designed to be 10 microamperes. The magnitude response arises from minus 126 dB at 1MHz until it reaches resonance frequency 10.2 GHz at 67.6 dB. The phase response for this current consumption starts from 0 degree. It rises slowly at 100 MHz until it reaches 73.1 degrees at 7.65 GHz. After that, it falls tremendously to minus 90.6 degrees at 12.8 GHz.

For sys2, which is shown in red dotted line, the current is designed to be 20 microamperes. The magnitude response arises from minus 114 dB at 1 MHz until it reaches resonance frequency 9.23 GHz at 60.9dB. The phase response for this current consumption starts from 0 degree. It rises slowly at 100 MHz until it reaches 71.5 degrees at 7.74 GHz. After that, it falls dramatically to minus 90.5 degrees at 11.5 GHz.

For sys3, which is shown in cyan dashed line, the current is designed to be 30 microamperes. The magnitude response arises from minus 107 dB at 1 MHz until it reaches resonance frequency 8.93 GHz at 61.7 dB. The phase response for this current consumption starts from 0 degree. It rises slowly at 100 MHz until it reaches 69.7 degrees at 7.24 GHz. After that, it falls sharply to minus 90.5 degrees at 10.4 GHz.

$$\begin{aligned}
 l_6 &= (2(C_{gd7} + C_L)f_5 + k_6) \\
 l_5 &= (C_{gd7} + C_L)f_4 + 2\left(g_{ds7} + \frac{1}{R_L}\right)f_5 + k_5 \\
 l_4 &= (C_{gd7} + C_L)f_3 + 2\left(g_{ds7} + \frac{1}{R_L}\right)f_4 + k_4 \\
 l_3 &= (C_{gd7} + C_L)f_2 + 2\left(g_{ds7} + \frac{1}{R_L}\right)f_3 + k_3 \\
 l_2 &= (C_{gd7} + C_L)f_1 + 2\left(g_{ds7} + \frac{1}{R_L}\right)f_2 + k_2 \\
 l_1 &= (C_{gd7} + C_L)f_0 + 2\left(g_{ds7} + \frac{1}{R_L}\right)f_1 + k_1 \\
 l_0 &= 2\left(g_{ds7} + \frac{1}{R_L}\right)f_0 + k_0
 \end{aligned}$$

$$\begin{aligned}
 m_6 &= 2C_L f_5 + k_6, m_5 = 2C_L f_4 + \frac{2f_5}{R_L} + k_5 \\
 m_4 &= 2C_L f_3 + \frac{2f_4}{R_L} + k_4, m_3 = 2C_L f_2 + \frac{2f_3}{R_L} + k_3 \\
 m_2 &= 2C_L f_1 + \frac{2f_2}{R_L} + k_2, m_1 = 2C_L f_0 + \frac{2f_1}{R_L} + k_1, m_0 = \frac{2f_0}{R_L} + k_0
 \end{aligned}$$

$$\begin{aligned}
 n_6 &= 2C_{gd8}f_5 + m_6 \\
 n_5 &= 2f_5g_{ds8} + 2C_{gd8}f_4 + m_5 \\
 n_4 &= 2f_4g_{ds8} + 2C_{gd8}f_3 + m_4 \\
 n_3 &= 2f_3g_{ds8} + 2C_{gd8}f_2 + m_3 \\
 n_2 &= 2f_2g_{ds8} + 2C_{gd8}f_1 + m_2 \\
 n_1 &= 2f_1g_{ds8} + 2C_{gd8}f_0 + m_1 \\
 n_0 &= 2g_{ds8}f_0 + m_0
 \end{aligned}$$

$$\begin{aligned}
 g_y &= g_{ds9} + g_{ds7} + g_{ds8} - g_{m7} - g_{m8} \\
 C_3 &= (C_{gd9} + C_{gs7} + C_{gs8}) \\
 o_7 &= n_6C_3, o_6 = n_5C_3 + n_6g_y \\
 o_5 &= n_4C_3 + n_5g_y - 2g_{ds8}(g_{ds8} - g_{m8})f_5 \\
 o_4 &= n_3C_3 + n_4g_y - 2g_{ds8}(g_{ds8} - g_{m8})f_4 \\
 o_3 &= n_2C_3 + n_3g_y - 2g_{ds8}(g_{ds8} - g_{m8})f_3 \\
 o_2 &= n_1C_3 + n_2g_y - 2g_{ds8}(g_{ds8} - g_{m8})f_2 \\
 o_1 &= n_0C_3 + n_1g_y - 2g_{ds8}(g_{ds8} - g_{m8})f_1 \\
 o_0 &= n_0g_7 - 2g_{ds8}(g_{ds8} - g_{m8})f_0
 \end{aligned}$$

$$\begin{aligned}
 p_7 &= m_6C_3, p_6 = m_5C_3 + m_6g_y \\
 p_5 &= m_4C_3 + m_5g_y + 2g_{ds8}(g_{ds8} - g_{m8})f_5 \\
 p_4 &= m_3C_3 + m_4g_y + 2g_{ds8}(g_{ds8} - g_{m8})f_4 \\
 p_3 &= m_2C_3 + m_3g_y + 2g_{ds8}(g_{ds8} - g_{m8})f_3 \\
 p_2 &= m_1C_3 + m_2g_y + 2g_{ds8}(g_{ds8} - g_{m8})f_2 \\
 p_1 &= m_0C_3 + m_1g_y + 2g_{ds8}(g_{ds8} - g_{m8})f_1 \\
 p_0 &= m_0g_7 + 2g_{ds8}(g_{ds8} - g_{m8})f_0
 \end{aligned}$$

$$\begin{aligned}
 q_6 &= 2C_{gs7} \times (g_{ds8} - g_{m8})f_5 \\
 q_5 &= 2C_{gs7}(g_{ds8} - g_{m8})f_4 - 2g_{m7}(g_{ds8} - g_{m8})f_5 \\
 q_4 &= 2C_{gs7}(g_{ds8} - g_{m8})f_3 - 2g_{m7}(g_{ds8} - g_{m8})f_4 \\
 q_3 &= 2C_{gs7}(g_{ds8} - g_{m8})f_2 - 2g_{m7}(g_{ds8} - g_{m8})f_3 \\
 q_2 &= 2C_{gs7}(g_{ds8} - g_{m8})f_1 - 2g_{m7}(g_{ds8} - g_{m8})f_2 \\
 q_1 &= 2C_{gs7}(g_{ds8} - g_{m8})f_0 - 2g_{m7}(g_{ds8} - g_{m8})f_1 \\
 q_0 &= -2g_{m7}(g_{ds8} - g_{m8})f_0
 \end{aligned}$$

$$\begin{aligned}
 r_2 &= (2\alpha_1 f_5), r_{11} = (2\alpha_1 f_1 + 2\alpha_1 f_5), r_{10} = (2\alpha_1 f_5 + 2\alpha_1 f_4 + 2\alpha_1 f_1), r_9 = (2\alpha_1 f_5 + 2\alpha_1 f_4 + 2\alpha_1 f_1 + 2\alpha_1 f_5) \\
 r_8 &= (2\alpha_1 f_1 + 2\alpha_1 f_5 + 2\alpha_1 f_4 + 2\alpha_1 f_1), r_7 = (2\alpha_1 f_5 + 2\alpha_1 f_4 + 2\alpha_1 f_1 + 2\alpha_1 f_5 + 2\alpha_1 f_1) \\
 r_6 &= (2\alpha_1 f_5 + 2\alpha_1 f_4 + 2\alpha_1 f_1 + 2\alpha_1 f_5 + 2\alpha_1 f_1), r_5 = (2\alpha_1 f_5 + 2\alpha_1 f_4 + 2\alpha_1 f_1 + 2\alpha_1 f_5 + 2\alpha_1 f_1 + 2\alpha_1 f_5) \\
 r_4 &= (2\alpha_1 f_5 + 2\alpha_1 f_4 + 2\alpha_1 f_1 + 2\alpha_1 f_5), r_3 = (2\alpha_1 f_5 + 2\alpha_1 f_4 + 2\alpha_1 f_1 + 2\alpha_1 f_5) \\
 r_2 &= (2\alpha_1 f_5 + 2\alpha_1 f_4 + 2\alpha_1 f_1), r_1 = (2\alpha_1 f_5 + 2\alpha_1 f_4), r_0 = 2\alpha_1 f_5 \\
 s_{12} &= (q_6(m_1 + n_6)), s_{11} = (q_6(m_1 + n_6) + q_6(m_1 + n_6)) \\
 s_{10} &= (q_6(m_1 + n_6) + q_6(m_1 + n_6) + q_6(m_1 + n_6)) \\
 s_9 &= (q_6(m_1 + n_6) + q_6(m_1 + n_6) + q_6(m_1 + n_6) + q_6(m_1 + n_6)) \\
 s_8 &= (q_6(m_1 + n_6) + q_6(m_1 + n_6) + q_6(m_1 + n_6) + q_6(m_1 + n_6) + q_6(m_1 + n_6)) \\
 s_7 &= (q_6(m_1 + n_6) + q_6(m_1 + n_6) + q_6(m_1 + n_6) + q_6(m_1 + n_6) + q_6(m_1 + n_6) + q_6(m_1 + n_6)) \\
 s_6 &= (q_6(m_1 + n_6) + q_6(m_1 + n_6) + q_6(m_1 + n_6) + q_6(m_1 + n_6) + q_6(m_1 + n_6) + q_6(m_1 + n_6) + q_6(m_1 + n_6)) \\
 s_5 &= (q_6(m_1 + n_6) + q_6(m_1 + n_6) + q_6(m_1 + n_6) + q_6(m_1 + n_6) + q_6(m_1 + n_6) + q_6(m_1 + n_6) + q_6(m_1 + n_6) + q_6(m_1 + n_6)) \\
 s_4 &= (q_6(m_1 + n_6) + q_6(m_1 + n_6) + q_6(m_1 + n_6) + q_6(m_1 + n_6) + q_6(m_1 + n_6) + q_6(m_1 + n_6) + q_6(m_1 + n_6) + q_6(m_1 + n_6) + q_6(m_1 + n_6)) \\
 s_3 &= (q_6(m_1 + n_6) + q_6(m_1 + n_6) + q_6(m_1 + n_6) + q_6(m_1 + n_6) + q_6(m_1 + n_6) + q_6(m_1 + n_6) + q_6(m_1 + n_6) + q_6(m_1 + n_6) + q_6(m_1 + n_6) + q_6(m_1 + n_6)) \\
 s_2 &= (q_6(m_1 + n_6) + q_6(m_1 + n_6) + q_6(m_1 + n_6) + q_6(m_1 + n_6) + q_6(m_1 + n_6) + q_6(m_1 + n_6) + q_6(m_1 + n_6) + q_6(m_1 + n_6) + q_6(m_1 + n_6) + q_6(m_1 + n_6) + q_6(m_1 + n_6)) \\
 s_1 &= (q_6(m_1 + n_6) + q_6(m_1 + n_6)) - s_0 = q_6(m_1 + n_6) \\
 t_{13} &= ((l_6 + m_6)o_5), t_{12} = ((l_6 + m_6)o_5 + (l_1 + m_1)o_5), t_{11} = ((l_6 + m_6)o_5 + (l_1 + m_1)o_5 + (l_1 + m_1)o_5) \\
 t_{10} &= ((l_6 + m_6)o_5 + (l_1 + m_1)o_5 + (l_1 + m_1)o_5 + (l_1 + m_1)o_5), t_9 = ((l_6 + m_6)o_5 + (l_1 + m_1)o_5 + (l_1 + m_1)o_5 + (l_1 + m_1)o_5 + (l_1 + m_1)o_5) \\
 t_8 &= ((l_6 + m_6)o_5 + (l_1 + m_1)o_5 + (l_1 + m_1)o_5 + (l_1 + m_1)o_5 + (l_1 + m_1)o_5 + (l_1 + m_1)o_5) \\
 t_7 &= ((l_6 + m_6)o_5 + (l_1 + m_1)o_5 + (l_1 + m_1)o_5 + (l_1 + m_1)o_5 + (l_1 + m_1)o_5 + (l_1 + m_1)o_5 + (l_1 + m_1)o_5) \\
 t_6 &= ((l_6 + m_6)o_5 + (l_1 + m_1)o_5 + (l_1 + m_1)o_5 + (l_1 + m_1)o_5 + (l_1 + m_1)o_5 + (l_1 + m_1)o_5 + (l_1 + m_1)o_5) \\
 t_5 &= ((l_6 + m_6)o_5 + (l_1 + m_1)o_5 + (l_1 + m_1)o_5 + (l_1 + m_1)o_5 + (l_1 + m_1)o_5 + (l_1 + m_1)o_5) \\
 t_4 &= ((l_6 + m_6)o_5 + (l_1 + m_1)o_5 + (l_1 + m_1)o_5 + (l_1 + m_1)o_5 + (l_1 + m_1)o_5) \\
 t_3 &= ((l_6 + m_6)o_5 + (l_1 + m_1)o_5 + (l_1 + m_1)o_5 + (l_1 + m_1)o_5) \\
 t_2 &= ((l_6 + m_6)o_5 + (l_1 + m_1)o_5 + (l_1 + m_1)o_5) \\
 t_1 &= ((l_6 + m_6)o_5 + (l_1 + m_1)o_5) \\
 t_0 &= (l_6 + m_6)o_5 \\
 u_{13} &= (p_1(m_1 + n_6)), u_{12} = (p_1(m_1 + n_6) + p_1(m_1 + n_6)) \\
 u_{11} &= (p_1(m_1 + n_6) + p_1(m_1 + n_6) + p_1(m_1 + n_6)) \\
 u_{10} &= (p_1(m_1 + n_6) + p_1(m_1 + n_6) + p_1(m_1 + n_6) + p_1(m_1 + n_6)) \\
 u_9 &= (p_1(m_1 + n_6) + p_1(m_1 + n_6) + p_1(m_1 + n_6) + p_1(m_1 + n_6) + p_1(m_1 + n_6)) \\
 u_8 &= (p_1(m_1 + n_6) + p_1(m_1 + n_6) + p_1(m_1 + n_6) + p_1(m_1 + n_6) + p_1(m_1 + n_6) + p_1(m_1 + n_6)) \\
 u_7 &= (p_1(m_1 + n_6) + p_1(m_1 + n_6) + p_1(m_1 + n_6) + p_1(m_1 + n_6) + p_1(m_1 + n_6) + p_1(m_1 + n_6) + p_1(m_1 + n_6)) \\
 u_6 &= (p_1(m_1 + n_6) + p_1(m_1 + n_6) + p_1(m_1 + n_6) + p_1(m_1 + n_6) + p_1(m_1 + n_6) + p_1(m_1 + n_6) + p_1(m_1 + n_6) + p_1(m_1 + n_6)) \\
 u_5 &= (p_1(m_1 + n_6) + p_1(m_1 + n_6) + p_1(m_1 + n_6) + p_1(m_1 + n_6) + p_1(m_1 + n_6) + p_1(m_1 + n_6) + p_1(m_1 + n_6) + p_1(m_1 + n_6) + p_1(m_1 + n_6)) \\
 u_4 &= (p_1(m_1 + n_6) + p_1(m_1 + n_6) + p_1(m_1 + n_6) + p_1(m_1 + n_6) + p_1(m_1 + n_6) + p_1(m_1 + n_6) + p_1(m_1 + n_6) + p_1(m_1 + n_6) + p_1(m_1 + n_6) + p_1(m_1 + n_6)) \\
 u_3 &= (p_1(m_1 + n_6) + p_1(m_1 + n_6) + p_1(m_1 + n_6) + p_1(m_1 + n_6) + p_1(m_1 + n_6) + p_1(m_1 + n_6) + p_1(m_1 + n_6) + p_1(m_1 + n_6) + p_1(m_1 + n_6) + p_1(m_1 + n_6) + p_1(m_1 + n_6)) \\
 u_2 &= (p_1(m_1 + n_6) + p_1(m_1 + n_6) + p_1(m_1 + n_6) + p_1(m_1 + n_6) + p_1(m_1 + n_6) + p_1(m_1 + n_6) + p_1(m_1 + n_6) + p_1(m_1 + n_6) + p_1(m_1 + n_6) + p_1(m_1 + n_6) + p_1(m_1 + n_6) + p_1(m_1 + n_6)) \\
 u_1 &= (p_1(m_1 + n_6) + p_1(m_1 + n_6) + p_1(m_1 + n_6) + p_1(m_1 + n_6) + p_1(m_1 + n_6) + p_1(m_1 + n_6) + p_1(m_1 + n_6) + p_1(m_1 + n_6) + p_1(m_1 + n_6) + p_1(m_1 + n_6) + p_1(m_1 + n_6) + p_1(m_1 + n_6) + p_1(m_1 + n_6)) \\
 u_0 &= (p_1(m_1 + n_6) + p_1(m_1 + n_6)) - u_6 = p_1(m_1 + n_6)
 \end{aligned}$$

$$\begin{aligned}
 v_{12} &= (2p_7f_3) \\
 v_{11} &= (2p_7f_4 + 2p_6f_5) \\
 v_{10} &= (2p_7f_5 + 2p_6f_4 + 2p_5f_5) \\
 v_9 &= (2p_7f_2 + 2p_6f_3 + 2p_5f_4 + 2p_4f_5) \\
 v_8 &= (2p_7f_1 + 2p_6f_2 + 2p_5f_3 + 2p_4f_4 + 2p_3f_5) \\
 v_7 &= (2p_7f_0 + 2p_6f_1 + 2p_5f_2 + 2p_4f_3 + 2p_3f_4 + 2p_2f_5) \\
 v_6 &= (2p_6f_0 + 2p_5f_1 + 2p_4f_2 + 2p_3f_3 + 2p_2f_4 + 2p_1f_5) \\
 v_5 &= (2p_5f_0 + 2p_4f_1 + 2p_3f_2 + 2p_2f_3 + 2p_1f_4 + 2p_0f_5) \\
 v_4 &= (2p_4f_0 + 2p_3f_1 + 2p_2f_2 + 2p_1f_3 + 2p_0f_4) \\
 v_3 &= (2p_3f_0 + 2p_2f_1 + 2p_1f_2 + 2p_0f_3) \\
 v_2 &= (2p_2f_0 + 2p_1f_1 + 2p_0f_2) \\
 v_1 &= (2p_1f_0 + 2p_0f_1) \\
 v_0 &= 2p_0f_0 \\
 w_{12} &= (q_6)(l_6 + m_6) \\
 w_{11} &= (q_6(l_5 + m_5) + q_5(l_6 + m_6)) \\
 w_{10} &= (q_6(l_4 + m_4) + q_5(l_5 + m_5) + q_4(l_6 + m_6)) \\
 w_9 &= (q_6(l_3 + m_3) + q_5(l_4 + m_4) + q_4(l_5 + m_5) + q_3(l_6 + m_6)) \\
 w_8 &= (q_6(l_2 + m_2) + q_5(l_3 + m_3) + q_4(l_4 + m_4) + q_3(l_5 + m_5) + q_2(l_6 + m_6)) \\
 w_7 &= (q_6(l_1 + m_1) + q_5(l_2 + m_2) + q_4(l_3 + m_3) + q_3(l_4 + m_4) + q_2(l_5 + m_5) + q_1(l_6 + m_6)) \\
 w_6 &= (q_6(l_0 + m_0) + q_5(l_1 + m_1) + q_4(l_2 + m_2) + q_3(l_3 + m_3) + q_2(l_4 + m_4) + q_1(l_5 + m_5) + q_0(l_6 + m_6)) \\
 w_5 &= (q_5(l_6 + m_6) + q_4(l_1 + m_1) + q_3(l_2 + m_2) + q_2(l_3 + m_3) + q_1(l_4 + m_4) + q_0(l_5 + m_5)) \\
 w_4 &= (q_4(l_6 + m_6) + q_3(l_1 + m_1) + q_2(l_2 + m_2) + q_1(l_3 + m_3) + q_0(l_4 + m_4)) \\
 w_3 &= (q_3(l_6 + m_6) + q_2(l_1 + m_1) + q_1(l_2 + m_2) + q_0(l_3 + m_3)) \\
 w_2 &= (q_2(l_6 + m_6) + q_1(l_1 + m_1) + q_0(l_2 + m_2)) \\
 w_1 &= (q_1(l_6 + m_6) + q_0(l_1 + m_1)) \\
 w_0 &= q_0(l_6 + m_6)
 \end{aligned}$$

(13)

$$\begin{aligned}
 x_{13} &= (v_{12}C_{gd7}), x_{12} = (v_{12}g_{m7} + v_{11}C_{gd7} + w_{12}), x_{11} = (v_{11}g_{m7} + v_{10}C_{gd7} + w_{11}) \\
 x_{10} &= (v_{10}g_{m7} + v_9C_{gd7} + w_{10}), x_9 = (v_9g_{m7} + v_8C_{gd7} + w_9), x_8 = (v_8g_{m7} + v_7C_{gd7} + w_8) \\
 x_7 &= (v_7g_{m7} + v_6C_{gd7} + w_7), x_6 = (v_6g_{m7} + v_5C_{gd7} + w_6), x_5 = (v_5g_{m7} + v_4C_{gd7} + w_5) \\
 x_4 &= (v_4g_{m7} + v_3C_{gd7} + w_4), x_3 = (v_3g_{m7} + v_2C_{gd7} + w_3), x_2 = (v_2g_{m7} + v_1C_{gd7} + w_2) \\
 x_1 &= (v_1g_{m7} + v_0C_{gd7} + w_1), x_0 = (v_0g_{m7} + w_0) \\
 y_{13} &= (o_7(l_6 + m_6)) \\
 y_{12} &= (o_7(l_5 + m_5) + o_6(l_6 + m_6)) \\
 y_{11} &= (o_7(l_4 + m_4) + o_6(l_5 + m_5) + o_5(l_6 + m_6)) \\
 y_{10} &= (o_7(l_3 + m_3) + o_6(l_4 + m_4) + o_5(l_5 + m_5) + o_4(l_6 + m_6)) \\
 y_9 &= (o_7(l_2 + m_2) + o_6(l_3 + m_3) + o_5(l_4 + m_4) + o_4(l_5 + m_5) + o_3(l_6 + m_6)) \\
 y_8 &= (o_7(l_1 + m_1) + o_6(l_2 + m_2) + o_5(l_3 + m_3) + o_4(l_4 + m_4) + o_3(l_5 + m_5) + o_2(l_6 + m_6)) \\
 y_7 &= (o_7(l_0 + m_0) + o_6(l_1 + m_1) + o_5(l_2 + m_2) + o_4(l_3 + m_3) + o_3(l_4 + m_4) + o_2(l_5 + m_5) + o_1(l_6 + m_6)) \\
 y_6 &= (o_6(l_6 + m_6) + o_5(l_1 + m_1) + o_4(l_2 + m_2) + o_3(l_3 + m_3) + o_2(l_4 + m_4) + o_1(l_5 + m_5) + o_0(l_6 + m_6)) \\
 y_5 &= (o_5(l_6 + m_6) + o_4(l_1 + m_1) + o_3(l_2 + m_2) + o_2(l_3 + m_3) + o_1(l_4 + m_4) + o_0(l_5 + m_5)) \\
 y_4 &= (o_4(l_6 + m_6) + o_3(l_1 + m_1) + o_2(l_2 + m_2) + o_1(l_3 + m_3) + o_0(l_4 + m_4)) \\
 y_3 &= (o_3(l_6 + m_6) + o_2(l_1 + m_1) + o_1(l_2 + m_2) + o_0(l_3 + m_3)) \\
 y_2 &= (o_2(l_6 + m_6) + o_1(l_1 + m_1) + o_0(l_2 + m_2)) \\
 y_1 &= (o_1(l_6 + m_6) + o_0(l_1 + m_1)) \\
 y_0 &= o_0(l_6 + m_6) \\
 z_{13} &= (p_7(m_6 + n_6)) \\
 z_{12} &= (p_7(m_5 + n_5) + p_6(m_6 + n_6)) \\
 z_{11} &= (p_7(m_4 + n_4) + p_6(m_5 + n_5) + p_5(m_6 + n_6)) \\
 z_{10} &= (p_7(m_3 + n_3) + p_6(m_4 + n_4) + p_5(m_5 + n_5) + p_4(m_6 + n_6)) \\
 z_9 &= (p_7(m_2 + n_2) + p_6(m_3 + n_3) + p_5(m_4 + n_4) + p_4(m_5 + n_5) + p_3(m_6 + n_6)) \\
 z_8 &= (p_6(m_2 + n_2) + p_5(m_3 + n_3) + p_4(m_4 + n_4) + p_3(m_5 + n_5) + p_2(m_6 + n_6)) \\
 z_7 &= (p_6(m_1 + n_1) + p_5(m_2 + n_2) + p_4(m_3 + n_3) + p_3(m_4 + n_4) + p_2(m_5 + n_5) + p_1(m_6 + n_6)) \\
 z_6 &= (p_6(m_0 + n_0) + p_5(m_1 + n_1) + p_4(m_2 + n_2) + p_3(m_3 + n_3) + p_2(m_4 + n_4) + p_1(m_5 + n_5) + p_0(m_6 + n_6)) \\
 z_5 &= s^5(p_5(m_0 + n_0) + p_4(m_1 + n_1) + p_3(m_2 + n_2) + p_2(m_3 + n_3) + p_1(m_4 + n_4) + p_0(m_5 + n_5)) \\
 z_4 &= (p_2(m_0 + n_0) + p_3(m_1 + n_1) + p_2(m_2 + n_2) + p_1(m_3 + n_3) + p_0(m_4 + n_4)) \\
 z_3 &= (p_3(m_0 + n_0) + p_2(m_1 + n_1) + p_1(m_2 + n_2) + p_0(m_3 + n_3)) \\
 z_2 &= (p_2(m_0 + n_0) + p_1(m_1 + n_1) + p_0(m_2 + n_2)) \\
 z_1 &= (p_1(m_0 + n_0) + p_0(m_1 + n_1)) \\
 z_0 &= p_0(m_0 + n_0)
 \end{aligned}$$

(14)

$$\begin{aligned}
 z_{113} &= y_{13} - z_{13}, z_{112} = y_{12} - z_{12}, z_{111} = y_{11} - z_{11}, z_{110} = y_{10} - z_{10}, z_{109} = y_9 - z_9 \\
 z_{108} &= y_8 - z_8, z_{107} = y_7 - z_7, z_{106} = y_6 - z_6, z_{105} = y_5 - z_5, z_{104} = y_4 - z_4, z_{103} = y_3 - z_3 \\
 z_{102} &= y_2 - z_2, z_{101} = y_1 - z_1, z_{100} = y_0 - z_0 \\
 y_{113} &= (r_{12}C_{gd7}), y_{112} = (r_{11}C_{gd7} + r_{12}g_{m7} + s_{12}), y_{111} = (r_{10}C_{gd7} + r_{11}g_{m7} + s_{11}) \\
 y_{110} &= (r_9C_{gd7} + r_{10}g_{m7} + s_{10}), y_{109} = (r_8C_{gd7} + r_9g_{m7} + s_9) \\
 y_{108} &= (r_7C_{gd7} + r_8g_{m7} + s_8), y_{107} = (r_6C_{gd7} + r_7g_{m7} + s_7) \\
 y_{106} &= (r_5C_{gd7} + r_6g_{m7} + s_6), y_{105} = (r_4C_{gd7} + r_5g_{m7} + s_5) \\
 y_{104} &= (r_3C_{gd7} + r_4g_{m7} + s_4), y_{103} = (r_2C_{gd7} + r_3g_{m7} + s_3) \\
 y_{102} &= (r_1C_{gd7} + r_2g_{m7} + s_2), y_{101} = (r_0C_{gd7} + r_1g_{m7} + s_1) \\
 y_{100} &= (r_0g_{m7} + s_0) \\
 t_{113} &= (t_{13} - u_{13}), t_{112} = (t_{12} - u_{12}), t_{111} = (t_{11} - u_{11}), t_{110} = (t_{10} - u_{10}), t_{109} = (t_9 - u_9) \\
 t_{108} &= (t_8 - u_8), t_{107} = (t_7 - u_7), t_{106} = (t_6 - u_6), t_{105} = (t_5 - u_5), t_{104} = (t_4 - u_4) \\
 t_{103} &= (t_3 - u_3), t_{102} = (t_2 - u_2), t_{101} = (t_1 - u_1), t_{100} = (t_0 - u_0)
 \end{aligned}$$

(15)

$$A_{12} = \frac{V_{o1}}{V_{i2}} = A_{21} = \frac{V_{o2}}{V_{i1}} = \frac{\begin{bmatrix} s^{13}x_{13} + s^{12}x_{12} + s^{11}x_{11} + s^{10}x_{10} + s^9x_9 + s^8x_8 + s^7x_7 \\ + s^6x_6 + s^5x_5 + s^4x_4 + s^3x_3 + s^2x_2 + sx_1 + x_0 \end{bmatrix}}{\begin{bmatrix} s^{13}z_{113} + s^{12}z_{112} + s^{11}z_{111} + s^{10}z_{110} + s^9z_{109} + s^8z_{108} + s^7z_{107} \\ + s^6z_{106} + s^5z_{105} + s^4z_{104} + s^3z_{103} + s^2z_{102} + sz_{101} + z_{100} \end{bmatrix}}$$

(16)

$$A_{22} = \frac{V_{o2}}{V_{i2}} = \frac{\begin{bmatrix} s^{13}y_{113} + s^{12}y_{112} + s^{11}y_{111} + s^{10}y_{110} + s^9y_{109} + s^8y_{108} + s^7y_{107} \\ + s^6y_{106} + s^5y_{105} + s^4y_{104} + s^3y_{103} + s^2y_{102} + sy_{101} + y_{100} \end{bmatrix}}{\begin{bmatrix} s^{13}t_{113} + s^{12}t_{112} + s^{11}t_{111} + s^{10}t_{110} + s^9t_{109} + s^8t_{108} + s^7t_{107} \\ + s^6t_{106} + s^5t_{105} + s^4t_{104} + s^3t_{103} + s^2t_{102} + st_{101} + t_{100} \end{bmatrix}}$$

(17)

$$\begin{aligned}
 A_m &= \frac{\begin{bmatrix} s^{13}y_{113} + s^{12}y_{112} + s^{11}y_{111} + s^{10}y_{110} + s^9y_{109} + s^8y_{108} + s^7y_{107} \\ + s^6y_{106} + s^5y_{105} + s^4y_{104} + s^3y_{103} + s^2y_{102} + sy_{101} + y_{100} \end{bmatrix}}{\begin{bmatrix} s^{13}z_{113} + s^{12}z_{112} + s^{11}z_{111} + s^{10}z_{110} + s^9z_{109} + s^8z_{108} + s^7z_{107} \\ + s^6z_{106} + s^5z_{105} + s^4z_{104} + s^3z_{103} + s^2z_{102} + sz_{101} + z_{100} \end{bmatrix}} \\
 A_m &= \frac{\begin{bmatrix} s^{13}x_{13} + s^{12}x_{12} + s^{11}x_{11} + s^{10}x_{10} + s^9x_9 + s^8x_8 + s^7x_7 \\ + s^6x_6 + s^5x_5 + s^4x_4 + s^3x_3 + s^2x_2 + sx_1 + x_0 \end{bmatrix}}{\begin{bmatrix} s^{13}z_{113} + s^{12}z_{112} + s^{11}z_{111} + s^{10}z_{110} + s^9z_{109} + s^8z_{108} + s^7z_{107} \\ + s^6z_{106} + s^5z_{105} + s^4z_{104} + s^3z_{103} + s^2z_{102} + sz_{101} + z_{100} \end{bmatrix}} \\
 A_m &= \frac{\begin{bmatrix} s^{13}y_{113} + s^{12}y_{112} + s^{11}y_{111} + s^{10}y_{110} + s^9y_{109} + s^8y_{108} + s^7y_{107} \\ + s^6y_{106} + s^5y_{105} + s^4y_{104} + s^3y_{103} + s^2y_{102} + sy_{101} + y_{100} \end{bmatrix}}{\begin{bmatrix} s^{13}t_{113} + s^{12}t_{112} + s^{11}t_{111} + s^{10}t_{110} + s^9t_{109} + s^8t_{108} + s^7t_{107} \\ + s^6t_{106} + s^5t_{105} + s^4t_{104} + s^3t_{103} + s^2t_{102} + st_{101} + t_{100} \end{bmatrix}}
 \end{aligned}$$

(18)

For fully differential bandpass amplifier in Fig. 5, it can be designed by a substitute drain current equation in the saturation region. After that all aspect ratios, transconductances, drain source conductances, parasitic capacitances can be designed and written as a function of current consumption in MATLAB. The theory which is used to analyze differential mode gain and common mode gain can be seen in a well known textbook [7]. All formulas from the (4) through (18) can be written in MATLAB with 536 lines as an input file. In typical simulation results, it can be shown in Figs. 8 and 9 that differential mode gain and common mode gain are approximately equal which is very strange results. It means that common mode rejection ratio of this circuit is approximately zero which is plotted in Fig. 7.

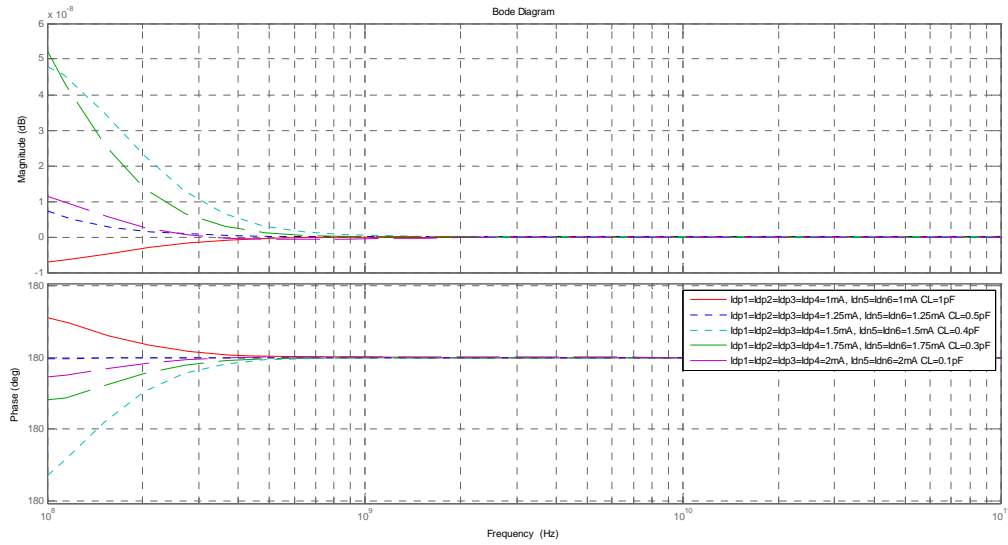

Fig. 7 Typical Magnitude and phase response of common mode rejection ratio (CMRR) of fully differential bandpass amplifier as a function of drain current $R_L = 10k\Omega$

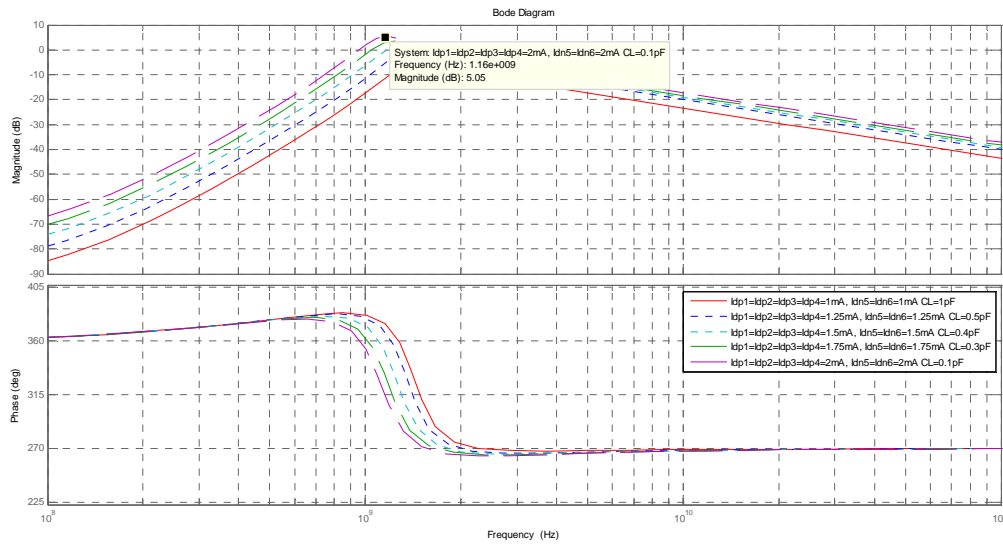

Fig. 8 Typical Magnitude and phase response of differential mode gain (Adm) of fully differential bandpass amplifier as a function of drain current $R_L = 10k\Omega$

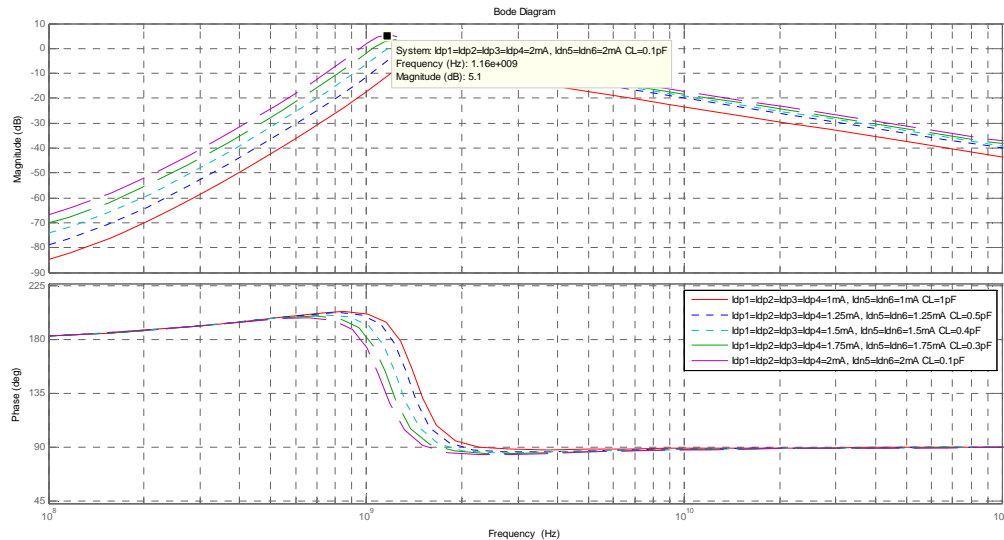

Fig. 9 Typical Magnitude and phase response of common mode gain (A_{cm}) of fully differential bandpass amplifier as a function of drain current $R_L = 10k\Omega$

IV. CONCLUSION

From a simulation with MATLAB, it can be concluded that center frequency and the voltage gain of a fully differential bandpass amplifier can be tuned by adjusting values of capacitive load, resistive load C_L, R_L and minimum length of transistors in Fig. 4 (a). The higher is the current, the lower the center frequency. It can be seen from the graph of differential mode gain in Fig. 7 that differential mode gain can be designed to be 5 dB at center frequency of 1.16 GHz at current consumption of 8 mA. It can be seen that for current consumption of 4mA, A_{dm} can be designed to be minus 3.86 dB at center frequency of 1.46 GHz. It can be concluded that this circuit consumed very high current if voltage gain is a stringent requirement.

REFERENCES

- [1] A. Thanachayanont, A. Payne, "VHF CMOS integrated active inductor", *Electronic Letters*, 23rd May 1996, Vol.32, No.11 pp.999-1000.
- [2] U. Yodprasit, J. Ngarmnil, "Q- enhancing technique for RF CMOS active inductor", *ISCAS2000*, pp V-589-V-592
- [3] Chao-Chih Hsiao, Chin-Wei Kuo, Chien-Chih Ho, Yi-Jen Chan, "Improved Quality factor of 0.18 μ m CMOS active inductor by a feedback resistance design", *IEEE Microwave and Wireless Components letters*, Vol.12, No.12, December 2002, pp.467-469
- [4] Y.-J. Jeong, Y.-M. Kim, H.-J. Chang, T.-Y. Yun, "Low power CMOS VCO with a low-current, high Q active inductor", *IET Microw. Antennas Propag.*, 2012, Vol.6, Iss. 7, pp.788-792
- [5] A. Thanachayanont, A. Payne, "CMOS floating active inductor and its applications to bandpass filter and oscillator designs", *IEE Proc.-Circuits Devices Syst.*, Vol.147, No.1, February 2000, pp.42-48
- [6] Liang-Hung Lu, Hsieh-Hung Hsieh, Yu-Te Liao, "A Wide Tuning Range CMOS VCO with a differential tunable active inductor", *IEEE Transactions on Microwave Theory and Techniques*, Vol.54, No.9, September 2006, pp. 3462-3468
- [7] Paul R. Gray, Paul J. Hurst, Stephen H. Lewis, Robert G. Meyer, "Analysis and Design of Analog Integrated Circuits", 4th edition, Copyright 2001, John Wiley & Sons, pp.221-224
- [8] Adel S. Sedra, Kenneth C. Smith, "Microelectronic Circuits", 5th edition, Copyright 2004, Oxford University Press, 2004, pp.355

Kittipong Tripetch (M'02) was born since 15 September 1972 in Bangkok, Thailand. He received his master degree in electrical engineering with a major in Microelectronic engineering from Mahanakorn University of Technology since 2002. He received his bachelor degree in electrical engineering with a major in Telecommunication engineering from Mahanakorn University of Technology since 1996. He received status member of IEEE since 2002. After graduation, he has been employed by division of electronic and telecommunication engineering, faculty of engineering and architecture, Rajamangala University of Technology Suvarnabhumi, Nonthaburi Campus since August 2004. He published conference paper about 8 papers in IEEE Explore since 2007. He has been lecturing 3 subjects in undergraduate courses of telecommunication engineering about engineering electronic, electronic communication and feedback control system.

He received second place in first national integrated circuit design contest about buffered operational amplifier in Thailand exhibited by the National electronic and computer technology center (NECTEC) since 2000. He has a plan to pursue PhD degree in Japan or Taiwan.