

Instrumentation for Studying Real-time Popcorn Effect in Surface Mount Packages during Solder Reflow

Arijit Roy

Abstract—Occurrence of popcorn in IC packages while assembling them onto the PCB is a well known moisture sensitive reliability issues, especially for surface mount packages. Commonly reflow soldering simulation process is conducted to assess the impact of assembling IC package onto PCB. A strain gauge-based instrumentation is developed to investigate the popcorn effect in surface mount packages during reflow soldering process. The instrument is capable of providing real-time quantitative information of the occurrence popcorn phenomenon in IC packages. It is found that the popcorn occur temperatures between 218 to 241°C depending on moisture soak condition, but not at the peak temperature of the reflow process. The presence of popcorn and delamination are further confirmed by scanning acoustic tomography as a failure analysis.

Keywords—Instrumentation, Popcorn, Real-time, Solder Reflow, Strain Gauge.

I. INTRODUCTION

PLASTIC IC packages are known to absorb moisture when exposed to humid ambient conditions during storage in tape and reel in the factory or during the service period. Moisture-induced delamination and package cracking during PCB reflow soldering remains one of the reliability issues for IC packages. When a plastic (epoxy resin) encapsulated IC package is exposed to normal ambient air (temperature, humidity), the molding compound (MC) absorbs moisture because it is hygroscopic material [1], [2]. During the solder reflow process at PCB assembly; the surface mount package is subjected to soldering shock temperatures. At these temperatures, the interface between die-pad and MC may delaminate under the action of thermal stresses caused by the thermal mismatch due to the differences in coefficients of thermal expansion between the constituent materials of the IC package. Moisture absorbed in the MC then diffuses into the delaminated interface resulting in a vapor pressure build-up in the delaminated gap. This gives rise to the deformation of the under-pad MC layer. Under extreme conditions where the maximum stress generated by this deformation exceeds the strength of the MC, package cracks emanate from the MC/die pad backside interface. This phenomenon of moisture-induced package cracking is known as “popcorn effect”. The process of popcorn is schematically shown in Fig. 1. References [1], [3]–[5] describe the detail of the mechanisms of occurrence of popcorn effect.

Arijit Roy is with the Department of Electronics, West Bengal State University, Barasat, Kolkata, India 700126 (phone: +91-9051503636; e-mail: arijitroy@live.com).

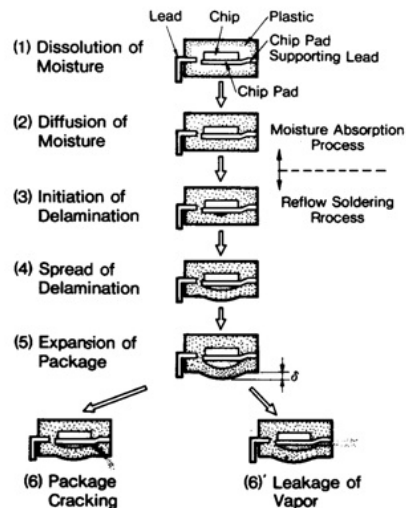

Fig. 1 Schematic representation of popcorn effect [6]

Few experimental attempts are made to analyze the popcorn effect in real-time. These attempts include opto-electrical [6] and strain gauge [7], [8] techniques to obtain real-time strain profile during the reflow soldering process. Among these techniques, investigation of popcorn effect using strain gauge technique is simple and cost effective with good deliverables. Strain gauge technique is developed [7], [8] and studied to understand the two dimensional strain in the IC packages during reflow soldering process. From these studies, it can be predicted that without much complex, the one dimensional real-time strain analysis would be useful to obtain quantitative information about the popcorn effect.

This work attempts to develop an electronic system to obtain real-time information of the popcorn effect. The system uses strain gauge based instrumentation to measure strain in arbitrary unit (a.u.) in finished IC packages during reflow soldering process. Failure analysis is conducted on the samples under investigation after the solder reflow process. Scanning acoustic tomography (SAT) is used as analytical tool for failure analysis of the samples under investigation.

II. EXPERIMENTATION

Experimentation for investigating the popcorn effect is divided into three parts such as (A) Instrumentation, (B) Study of real-time popcorn effect and (C) Failure analysis by SAT. These three parts are described below.

A. Instrumentation

The total instrumentation part is divided into three parts. The first part is the strain gauge circuit which acts as primary sensing element. It is important to achieve good linearity and temperature compensation capability. Additional circuitry to achieve these two functionalities can be thought of as signal conditioning element. The last functional block of the instrumentation is a wireless data transfer device which provides real-time data from the strain gauge circuitry. However, for ease of understanding, first, strain gauge circuit is described, then wireless data collection is described and finally, linearity and temperature compensation capability is explained under instrumentation.

1. Strain Gauge Circuit

Strain gauges are widely used as primary sensing element. A strain gauge is an electrical resistor of which the resistance changes due to the application of stress. Wheatstone bridge is employed to convert the strain from a strain gauge into a voltage signal.

Note that the soldering reflow process involves temperature variation. Hence, apart from the resistance change of the gauge due to the strain, there is also resistance change due to the resistivity change of the gauge as a result of temperature variation. Thus temperature compensation is required to obtain the resistance change of the gauge only due to strain. The temperature compensation is done by using an identical dummy unmounted strain gauge, which will go through the same temperature cycle during reflow process and will deliver change in its resistance only due to temperature variation. The Wheatstone bridge circuit configuration is shown in Fig. 2.

The output voltage of bridge is given by $V_o = V_i [\Delta R / 4R]$, where, V_i is excitation voltage of the bridge, R is the bridge resistance and ΔR is the change in resistance due to strain. The nominal resistance of the strain gauges used here is 350Ω (ZFLA-3•350-11). The maximum strain limit of this gauge is 1% with a gauge factor of 2.04. Hence, the maximum allowed change in the resistance of the gauge is $2.04 \times 350 \times 0.01 \Omega$, i.e. 7.14Ω . Therefore, the maximum voltage output from the bridge is 25.5 mV when the bridge excitation voltage is 5 V.

2. Wireless System for Real-time Data Collection

Since, the temperature variation is very rapid during the reflow process, it is extremely important to have automated real-time data acquisition system. This automation is configured to display the real-time plots while saving the data.

In order to obtain accurate data, a commercial wireless data transmitter such as SlimKIC™ is used in this work. The SlimKIC™ is a device designed to transmit and display data accurately for a variety of thermal processes. It can be used as a real-time thermal data transmitter, a direct connect profiler, or as a data storage profiler. It has the capability of wireless data transmission of 12 channels. The receiver along with the software of the device provides real-time plots on computer screen. The transmitter is covered with a thermal shield to protect it from high temperature and this allows user to put it

into the reflow oven.

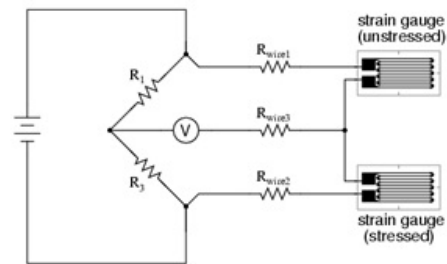

Fig. 2 Wheatstone bridge configuration of strain gauge circuit. The strain gauge labeled by 'strained' is mounted on the IC package under investigation and the one labeled by 'unstrained' is the dummy gauge for temperature compensation.

In order to obtain accurate data, a commercial wireless data transmitter such as SlimKIC™ is used in this work. The SlimKIC™ is a device designed to transmit and display data accurately for a variety of thermal processes. It can be used as a real-time thermal data transmitter, a direct connect profiler, or as a data storage profiler. It has the capability of wireless data transmission of 12 channels. The receiver along with the software of the device provides real-time plots on computer screen. The transmitter is covered with a thermal shield to protect it from high temperature and this allows user to put it into the reflow oven.

The bridge output is fed to one among the 12 channels of the SlimKIC™ device. Other channels can be fed to appropriate thermocouples to monitor the reflow oven temperature. The specifications of SlimKIC™ are considered while designing the bridge circuit. Thus a wireless real-time monitoring provision is made to obtain the quantitative information about the popcorn effect.

3. Checking Linearity and Temperature Compensation

Before conducting the actual experiment using the system, it is important to check the system linearity and temperature compensation capability within its target range of operation. With the increase in temperature of the gauge, an unmounted gauge may suffer from intrinsic strain and also rise in its resistance due to the positive temperature coefficient of resistivity (TCR) of gauge foil material. Both these factors need to be minimized as far as possible.

The linearity with temperature variation of the system is checked and compared with the data obtained using a thermocouple. For linearity check, the dummy strain gauge is replaced by a discrete resistance (350Ω). The other strain gauge is kept unmounted and subjected to the temperature variation only in the reflow oven. The JEDEC 260°C standard temperature profile is used and the obtained profiles are shown in Fig. 3.

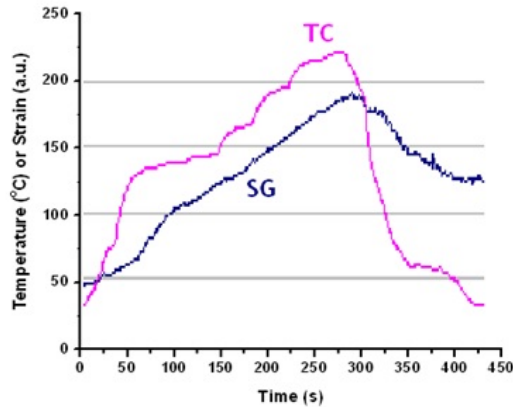

Fig. 3 Strain gauge linearity checking with JEDEC 260 °C profile. Here SG and TC stand for response from strain gauge and thermocouple respectively

From Fig. 3, it can be seen that the strain gauge response follows the oven temperature. The change in the temperature causes the resistivity change of the strain gauge and hence the variation occurs in Fig. 3 as a function of temperature (or time).

In a similar way, temperature compensation capability is also tested. In this case, both dummy (unstressed) and active gauges are kept unmounted and both are subjected to temperature variation simultaneously in the reflow oven with JEDEC 260°C profile. The responses from thermocouple and strain gauge circuit are shown in Fig. 4. From this figure, one can see that the response from the gauge circuit is quite flat. The flatness of this response qualifies the temperature compensation capability. In order to gain confidence on the temperature compensation capability, the above mentioned process is being repeated few times and the flatness of the response is tested.

B. Study of Real-time Popcorn Effect

In order to study the popcorn effect, moisture sensitive IC packages are considered. The IC packages are subjected to controlled moisture environments. The strain gauges are then mounted on samples for final test.

1. Sample Preparation and Strain Gauge Mounting

Finished ICs with black compound MQFP packages are used as samples for this study. Samples are preconditioned with two different moisture levels. First group of samples are subjected to preconditioning with 85% relative humidity at 85°C for 312 hrs (Group-A samples). The second group of samples is subjected to the same preconditioning ambient but for 384 hrs (Group-B samples). The samples are cured at room temperature after moisture soak. The above choices of the preconditioning levels are taken for this experiment so that the samples become more prone to popcorn.

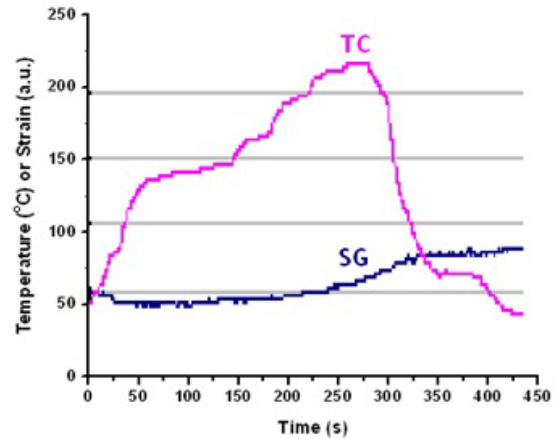

Fig. 4 Temperature compensation capability testing. Here SG and TC stand for response from strain gauge and thermocouple respectively

To attach the strain gauge on the IC packages, first the bottom surface of the sample is cleaned. The strain gauge is then mounted on the bottom side of the sample using a special adhesive (thin film type) which can withstand at temperature up to 400°C. The adhesive takes 5 to 6 hrs time to cure with a pressure of 50 – 300 kPa. It is to be noted here that the curing is done at room temperature and the adhesive does not content moisture which may affect the result.

2. Testing Real-time Popcorn Effect

The sample (with mounted strain gauge), the dummy gauge, the bridge circuit and the SlimKIC™ are kept into the reflow oven. To protect the bridge circuit from high temperature, it is kept inside the thermal shield of the SlimKIC™. The dummy gauge is freely kept near by the sample. The bridge output is connected to one of the input channels of the SlimKIC™ and a thermocouple is connected to another input channel. Thus it is possible to see both the variation of temperature and strain at the same time. A computer along with the receiver is arranged to collect the data from SlimKIC™ and to display the real-time plots for temperature and strain. The thermal profile standard for the IC package used in this study is JEDEC 225°C. However, a higher temperature profile such as JEDEC 260°C is used in this study to ensure the occurrence of popcorn. The experimental setup is shown in Fig. 5.

The abovementioned experiment is conducted and real-time plots are obtained. Such real-time plots are shown in Fig. 6 for a Group-A sample. Similarly real-time plots for a Group-B sample are obtained and are shown in Fig. 7.

C. Failure Analysis by SAT

SAT is widely used as analytical tool for inspection of IC package related issues. Both samples (for which popcorn effect is studied) are investigated using SAT and obtained SAT images are shown in Fig. 8.

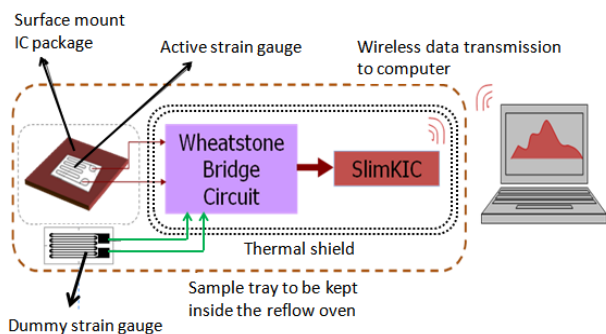

Fig. 5 Experimental setup for real-time popcorn monitoring

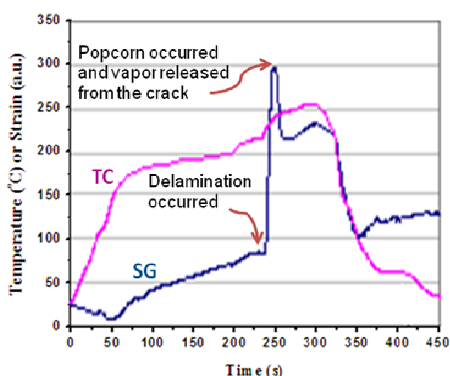

Fig. 6 Real-time monitoring of popcorn effect (Group-A sample).

Here SG and TC stand for response from strain gauge and thermocouple respectively. From SG response, occurrence of delamination and popcorn can be identified

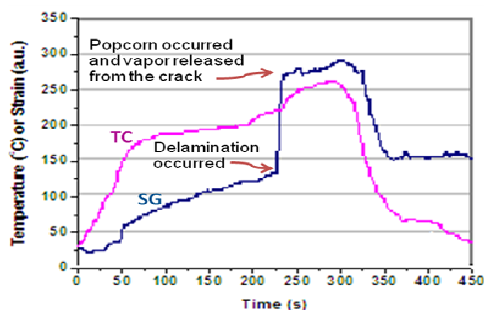

Fig. 7 Real-time plots of popcorn effect (Group-B sample).

III. RESULTS AND DISCUSSION

The present experiment allows observation of the real-time variation of temperature and strain of IC package during reflow process simultaneously which in turn allows critical investigation on the popcorn effect. The strain responses of moisture absorbed ICs as a function of time (or temperature) showing three distinguishable characteristics, such as: (a) a gradual increase, (b) a sharp increase and (c) a sharp fall (see Figs. 6 and 7).

The gradual increase portion is expected and it is due to the increase in strain (thermal strain due to increase in temperature of IC package). The sharp increase is due to the

moisture induced strain at the bottom of the package (corresponds to the situation shown in step 5 of the Fig. 1). The peak in the strain response is the signature of maximum deformation (and hence occurrence of popcorn) of the IC package that occurs during the reflow process. Finally, the sharp fall in strain response provides the signature of the vapor released from the deformed IC package (corresponds to the situation shown in step 6 of the Fig. 1).

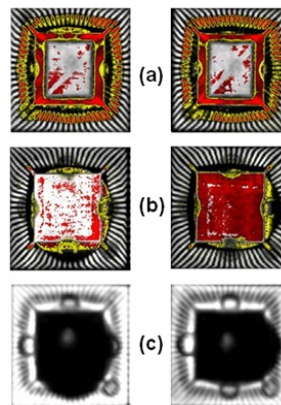

Fig. 8 SAT scan investigation (left column: Group-A sample, right column: Group-B sample). Not much difference is observed between Group-A and Group-B samples. (a) Top-scan on die paddle. Full delamination is observed. (b) Bottom-scan on leads. No delamination is observed (expected). (c) Thru-scan. About 95% die-attach delamination is observed

For Group-A sample, the first turning point in the strain response is resulted (see Fig. 6) due to the occurrence of delamination of die-attachment. This turning point occurs at time 245 sec. and at the oven temperature of 235°C. Then a very sharp increase in strain is observed. This is resulted from the propagation of delamination. After that the strain suddenly drops. At the peak of the strain response, the popcorn occurs and the vapor is released. The peak is found to occur at time 252 sec. and at a temperature of 241°C. Note that the popcorn occurred not the peak temperature of the thermal profile, whoever it occurs before the profile peak temperature. The SAT investigation reveals that 95% delamination for the Group-A sample.

Some of the samples (Group-A) are subjected to the same reflow process for another two times. From their strain responses it is noticed that the starting strain is bit higher (about 45°C in the temperature scale) in the second or third pass compared to the same in the first pass. This is because the occurrence of popcorn during the first pass creates a permanent package deformation.

The strain response for Group-B sample is found to be similar to that of Group-A sample. However for Group-B sample, it is found that the peak and turning points occurs earlier in time in contrast to Group-A sample in their strain responses. As an example, from Fig. 7, it is clear that for Group-B sample, the first turning point appears at time 226

sec. and at temperature of 218°C. The downward turn in the strain response is found at time 236 sec and at temperature of 223°C. These mean that the delamination occurs at 218°C and popcorn occurs at 223°C for Group-B sample. Note that for Group-B sample, both the delamination and popcorn occurrence temperatures are lower than of Group-A sample. This is expected, since Group-B sample absorbed more moisture than Group-A sample. Thus the moisture sensitivity with respect to solder reflow process can be measured accurately.

IV. CONCLUSION

An electronic system is developed to obtain real-time quantitative information of the popcorn effect in surface mount packages during solder reflow process. Experiments are conducted to identify the critical information of the popcorn effect and severity of popcorn or delamination depends on the moisture soak condition of the specimen. It is found that the popcorn occurs at lower temperature than the peak temperature of the reflow profile. After occurrence of popcorn, permanent package deformation is noticed. If applied suitably, the system developed here can be used to study other package related reliability issues.

REFERENCES

- [1] I. Fukuzawa, S. Ishiguro, S. Nabu Young, "Moisture resistance degradation of plastic LSI's by reflow soldering", in Proc. IEEE Annu. Int. Relia. Phys. Symp., 1985, pp. 192-197.
- [2] T. C. Chai, K. L. Chan, E. H. Wong, X. J. Fan, T. B. Lim, "Achieving crack free package through elimination of type II failure", in Proc. 49th IEEE ECTC, 1999, pp. 702-707.
- [3] P. Alpern, R. Dudek, R. Schmidt, V. Wicher, R. Tilgner, "On the mode II popcorn effect in thin packages", IEEE Trans. Comp. Pack. Technol., vol. 25(1), pp. 56-65, 2002.
- [4] P. Alpern, K.C. Lee, R. Dudek, R. Tilgner, "A simple model for the mode I popcorn effect for IC packages with copper leadframe", IEEE Trans. Comp. Pack. Technol., vol. 25(2), pp. 301-308, 2002.
- [5] X. Cai, W. Huang, B. Xu, G. Kaltenpoth, Z. Cheng, "A study of moisture diffusion in plastic packaging", J. Electronic Mat., vol. 31(5), pp. 449-455, 2002.
- [6] M. Kitano, A. Nishimura, R. Kohno, "Development of damage detection system for surface mount packages during reflow soldering", in Proc. IEEE, 1991, pp. 615-620.
- [7] J. Lau, R. Chen, C. Chang, "Real-time popcorn analysis of plastic ball grid array packages during solder reflow", in Proc. IEEE CPMT Int'l Elect. Manufac. Technol. Symp., 1998, pp. 455-463.
- [8] H. J. Moon, T.G. Chung, H. Lee, E.C. Ahn, T.J. Cho, S.Y. Oh, "Experimental stress analysis for flip chip BGA packages using strain gauge", in Proc. IEEE, 1999, pp. 510-513.

Dr. Arijit Roy has attended many prestigious institutes like IITs, NTU, Infineon Technologies in his career. He earned Ph.D. from School of Electrical and Electronic Engineering, Nanyang Technological University, Singapore in Jan 2008. Before pursuing full-time research career, he obtained M. Tech. (Instru. Tech.) and M.Sc. (Physics) from Indian Institute of Technology-Delhi and Indian Institute of Technology-Kharagpur in 2001 and 1999 respectively. So far he has published 16 research papers in peer-reviewed international journals of high impact factor (total impact factor of these journals is about 34), 4 peer-reviewed research papers in international conference of repute. Apart from these, Dr. Roy has delivered few invited talk in recognized conferences. His research articles are being cited more than 130 times as of now. Among his various publications, a 75-journal-page-size

review article (the longest documented work in the history of the topic) on Electromigration published in Materials Science and Engineering Reports: R is well received by the community. Another novel work is published in Microelectronic Engineering 113 (2014) 152-156. His research interest include: micro/nano-electronics, quantum computation, science teaching etc.

He was awarded "International Research Scholarship" from NTU for pursuing PhD. He obtained additional research grant from IME, Singapore during his PhD career. He won the prize for second-best-paper in "Symposium On Microelectronics-2004". Also, he ranked 31 (all India) in GATE'99 examination.

Presently Dr. Roy is Assistant Professor in Electronics at West Bengal State University. Before joining to this position, he was employed in Infineon Technologies and NTU in the position of Engineer and Research Associate respectively. He is the first Head of the Department of Electronics at WBSU, and involved in shaping the department for academic excellence.