

Notes on Vibration Design for Piezoelectric Cooling Fan

Thomas Jin-Chee Liu, Yu-Shen Chen, Hsi-Yang Ho, Jyun-Ting Liu, Chih-Chun Lee

Abstract—This paper discusses some notes on the vibration design for the piezoelectric cooling fan. After reviewing the fundamental formulas of the cantilever Euler beam, it is not easy to find the optimal design of the piezoelectric fan. The experiments also show the complicated results of the vibration behavior and air flow.

Keywords—Piezoelectric cooling fan, vibration, cantilever Euler beam, air flow.

I. INTRODUCTION

PIEZOELECTRIC materials and actuators are widely applied in modern technologies due to the capability of the transfer between mechanical and electric energy. The piezoelectric cooling fan as shown in Fig. 1 is one of the piezoelectric products. This cooling idea was first proposed by Toda and Osaka [1]. With the vibrating or flapping motion, the blade of this cooling fan can produce the air flow to reduce the temperature of hot electronic devices.

Many research topics for the piezoelectric cooling fan have been studied experimentally and numerically [1]-[6]. The experimental, analytical and numerical methods of solid and fluid mechanics are adopted in those researches. Many studies concluded that the piezoelectric cooling fan consumes low power and has good cooling performance for the electronic devices. For smaller electronic products, the space may not allow to set a rotary cooling fan. To solve this problem, the small-sized piezoelectric cooling fan is a good solution.

Yoo et al. have investigated several designs of piezoelectric cooling fans for the electronic devices [2]. In their study, several types of piezoelectric fans were constructed and tested at 60Hz, 110V, and 220V, respectively. They found a relationship between the blade tip displacement and the wind velocity when the piezoelectric fan is operated in the fundamental resonance. However, the effect of different working frequencies was not studied by Yoo et al.

The purpose of this paper is to discuss some notes on the vibration design of the piezoelectric cooling fan. The present study is the fluid-structure interaction problem. The experimental results will show the vibration behavior, air flow

Thomas Jin-Chee Liu, Associate Professor, is with the Department of Mechanical Engineering, Ming Chi University of Technology, Taishan, New Taipei City, Taiwan (corresponding author to provide phone: 886-2-29089899 ext 4569; e-mail: jinchee@mail.mcut.edu.tw).

Y.S. Chen, H.Y. Ho and J.T. Liu are graduate students in the Graduate Institute of Electro-Mechanical Engineering, Ming Chi University of Technology, Taishan, New Taipei City, Taiwan.

C.C. Lee is an undergraduate student in the Department of Mechanical Engineering, Ming Chi University of Technology, Taishan, New Taipei City, Taiwan.

and cooling performance of the piezoelectric cooling fan.

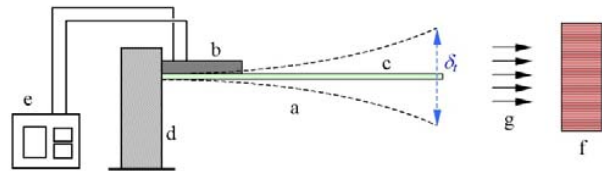

Fig. 1 Piezoelectric cooling fan and cooling mechanism (a: piezoelectric cooling fan; b: piezoelectric actuator; c: blade; d: fixture; e: electric power; f: electronic device; g: air flow; δ_t : total tip displacement)

II. PROBLEM STATEMENTS

Fig. 2 shows the geometry of the piezoelectric cooling fan in this study. The parameters L_1 , L_2 , L_3 , W_b , and W_p are main dimensions. The thicknesses t_e , t_p , t_c , t_g , and t_b belong to the thin-film electrode, piezoelectric actuator, copper electrode, glue, and blade, respectively.

As shown in Fig. 2, the actuator with two bonded piezoelectric materials is named as the bimorph actuator. The piezoelectric material is actuated by the electric field between two electrodes. When the voltage (electric potential) difference is applied on both electrodes, the piezoelectric actuator deforms or bends due to the electric field.

To perform the vibrating blade associated with the air flow, the piezoelectric cooling fan must be fixed and subjected to the electric power with the alternative current (AC). Fig. 3 shows the boundary conditions of the piezoelectric cooling fan. The copper electrode is grounded ($V_2=0$ V), and two thin-film electrodes are subjected to the AC voltage $V_j = V_{amp} \sin(2\pi ft)$ V. In above equation, the parameters f and t are the AC frequency and time, respectively.

The electro-mechanical coupling behavior of the transversely isotropic piezoelectric material is ruled by the constitutive equation under the Cartesian coordinate x_1 - x_2 - x_3 [7], [8]:

$$\begin{Bmatrix} T_{11} \\ T_{22} \\ T_{33} \\ T_{23} \\ T_{12} \\ D_1 \\ D_2 \\ D_3 \end{Bmatrix} = \begin{bmatrix} c_{11} & c_{12} & c_{13} & 0 & 0 & 0 & 0 & 0 & e_{31} \\ & c_{11} & c_{13} & 0 & 0 & 0 & 0 & 0 & e_{31} \\ & & c_{33} & 0 & 0 & 0 & 0 & 0 & e_{33} \\ & & & c_{44} & 0 & 0 & 0 & e_{15} & 0 \\ & & & & c_{44} & 0 & e_{15} & 0 & 0 \\ & & & & & c_{66} & 0 & 0 & 0 \\ & & & & & & c_{66} & 0 & 0 \\ & & & & & & & -\varepsilon_{11} & 0 \\ & & & & & & & -\varepsilon_{11} & 0 \\ & & & & & & & & -\varepsilon_{33} \end{bmatrix} \begin{Bmatrix} S_{11} \\ S_{22} \\ S_{33} \\ 2S_{23} \\ 2S_{13} \\ 2S_{12} \\ -E_1 \\ -E_2 \\ -E_3 \end{Bmatrix} \quad (1a)$$

$$c_{66} = \frac{1}{2}(c_{11} - c_{12}) \quad (1b)$$

where T, S, D, E, c, e and ε are the stress, strain, electric displacement, electric field, elastic constant, piezoelectric constant, and permittivity, respectively. In (1), the poling direction of the piezoelectric material is along the x_3 -axis. In this study, the bimorph actuator is made of the piezoelectric ceramic PZT-5H. Fig. 3 shows the poling directions (P vectors) of both piezoelectric materials of the bimorph. Due to the relatively thin thickness, the thin-film electrode and glue can be ignored in the analysis.

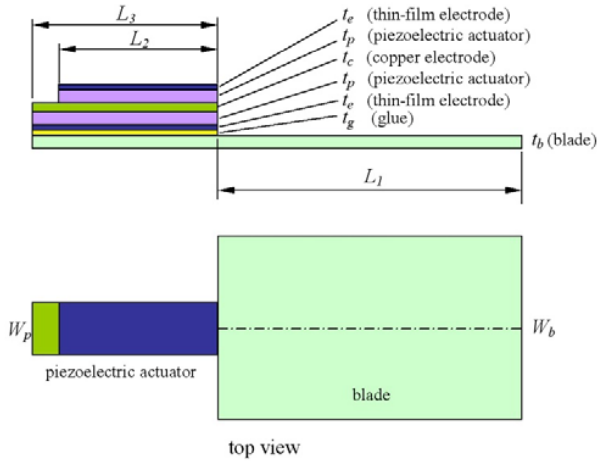

Fig. 2 Geometry of piezoelectric cooling fan

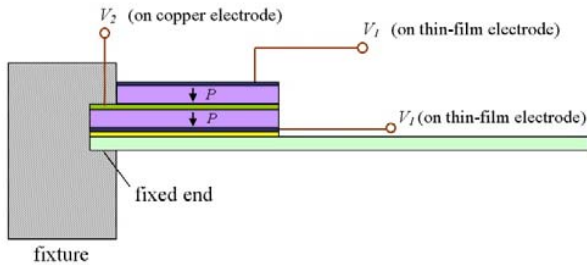

Fig. 3 Boundary conditions of piezoelectric cooling fan

III. EXPERIMENTAL STUDIES: VIBRATION BEHAVIOR AND AIR FLOW

Fig. 4 shows the experimental equipments for measuring the air flow in this study. The piezoelectric cooling fan is actuated by the AC voltage (i.e., $V_1 = V_{amp} \sin(2\pi ft)$) made from the electric signal source and amplifier. The input of the voltage V_1 is applied on the piezoelectric actuator. The air flow velocity from the piezoelectric fan is measured by the anemometer and sensor. Also, the total tip displacement of the vibrating blade is measured by the laser displacement sensor as shown in Fig. 5.

The piezoelectric cooling fans as shown in Fig 6 are used in the experiments. The dimensions are $L_1=60\text{mm}$, $L_2=32\text{mm}$, $L_3=36\text{mm}$, $W_b=60\text{mm}$, $W_p=10\text{mm}$, $t_p=0.3\text{mm}$, and $t_c=0.1\text{mm}$.

As shown in Fig. 6 (a) and (b), the materials used for of the blade are the PET plastics and SUS 304 stainless steel.

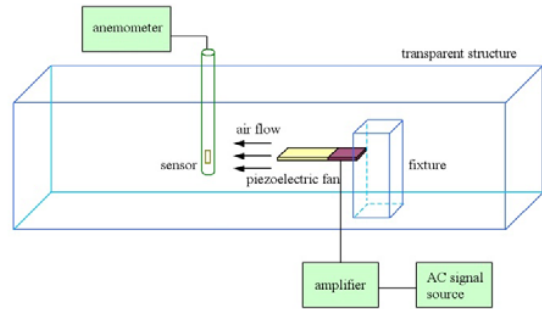

(a)

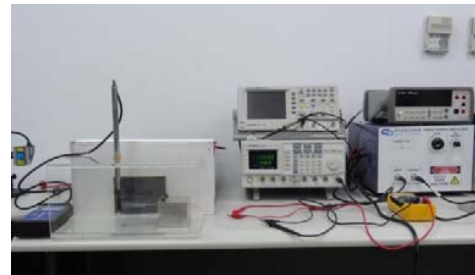

(b)

Fig. 4 Experimental equipments for air flow in this study (a) Layout figure (b) Photo

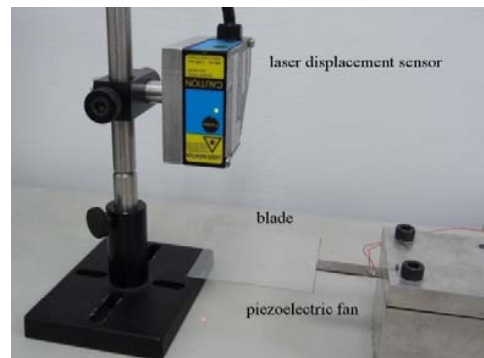
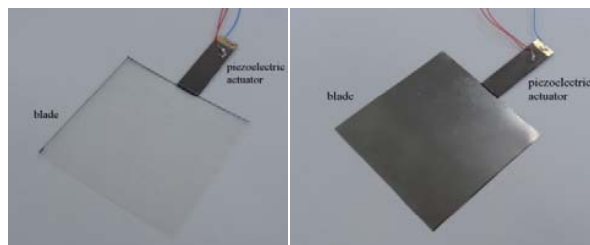

Fig. 5 Experimental equipments for blade tip displacement



(a)

(b)

Fig. 6 Piezoelectric cooling fan (a) PET blade (b) Stainless steel blade

Fig. 7 shows the vibration performance of the piezoelectric cooling fan with PET blade ($t_b=0.25\text{mm}$). It vibrates resonantly under its first-mode natural frequency $f_1=17.5\text{Hz}$. The resonant vibration performs the maximum flapping displacement. As shown in Fig. 8 when the applied frequency is shifted out of the natural frequency, the flapping displacement (total tip displacement) of the blade decreases rapidly.

When the PET blades with $t_b=0.25\text{mm}$ and $t_b=0.188\text{mm}$ are used, the variations of the air flow velocity v_{air} and tip displacement δ_t with applied voltage V_{amp} are respectively shown in Figs. 9 and 10. It presents the non-linear phenomena due to the flexible property and larger deformation. The results show that the larger voltage applied on the piezoelectric actuator can induce larger flapping displacement (total tip displacement) and air flow. In other words, the larger the tip displacement is, the larger the air flow velocity is. The effects of the blade thickness on the air flow and tip displacement are also considered. Due to different structural stiffness, the natural frequencies of $t_b=0.25\text{mm}$ and $t_b=0.188\text{mm}$ are $f_1=17.5\text{Hz}$ and $f_1=11.5\text{Hz}$, respectively. In Fig. 10, the tip displacements of $t_b=0.188\text{mm}$ are always larger than those of $t_b=0.25\text{mm}$. However, Fig. 9 shows that the air flow velocity of $t_b=0.188\text{mm}$ are not always larger than those of $t_b=0.25\text{mm}$. When $V_{amp}>75\text{V}$, the case of $t_b=0.25\text{mm}$ gets larger air flow. In this voltage range, higher working frequency of $t_b=0.25\text{mm}$ ($17.5\text{Hz}>11.5\text{Hz}$) dominates the air flow.

When the steel blades are used, similar complicated results are obtained. The steel blade thicknesses are $t_b=0.05\text{mm}$, $t_b=0.1\text{mm}$, and $t_b=0.2\text{mm}$. From the experimental measurement, their natural frequencies are $f_1=9.5\text{Hz}$, $f_1=14\text{Hz}$, and $f_1=18.5\text{Hz}$, respectively. The variations of v_{air} and δ_t with V_{amp} are respectively shown in Figs. 11 and 12. The case of $t_b=0.1\text{mm}$ has larger air flow and tip displacement than other two cases with thinner or thicker thickness. The blade thickness affects the natural frequency and tip displacement so that the air flow performs complicated results in Fig 11. However, the case of $t_b=0.1\text{mm}$ shows the approximately linear relationship between v_{air} and V_{amp} . This linear case agrees with those of Yoo et al. [2].

The piezoelectric cooling fan must work at the natural frequency to perform the resonant vibration. The larger blade tip deflection is also expected. Above two phenomena can produce larger air flow for the cooling process. However, the natural frequency of the piezoelectric fan must be high enough. Otherwise, low working frequency will produce small air flow even if the blade tip deflection becomes very large. In addition, very high natural frequency should be avoided due to the large electric power consumption and low fatigue life.

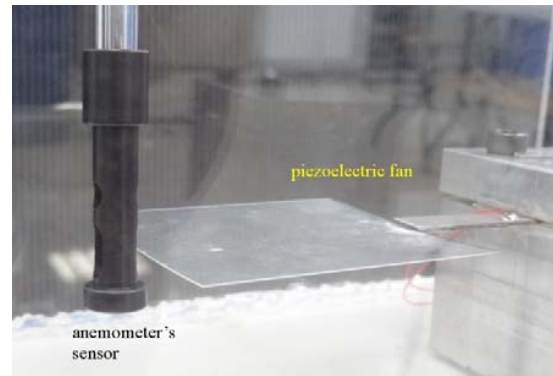

(a)

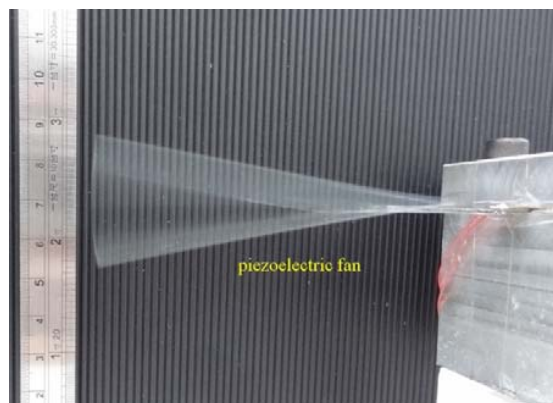

(b)

Fig. 7 Vibration of piezoelectric cooling fan with PET blade (a) piezoelectric fan and anemometer, (b) resonant vibration under 17.5Hz.

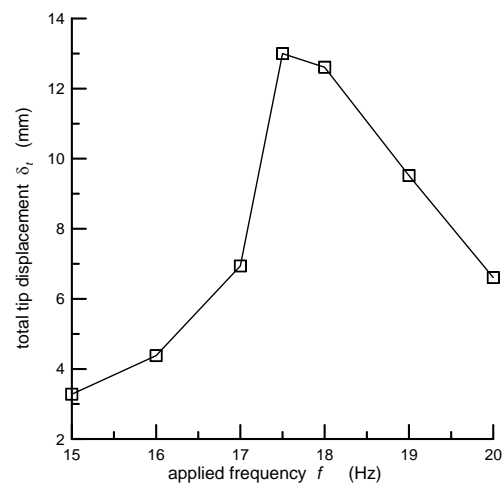
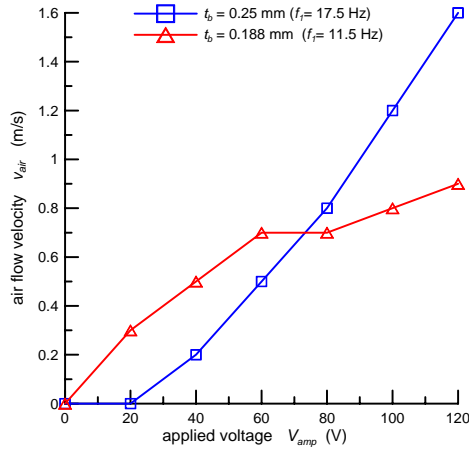
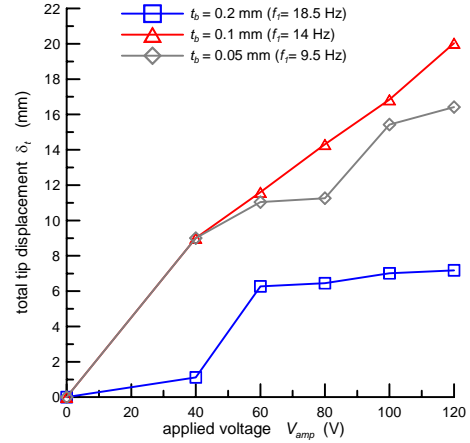
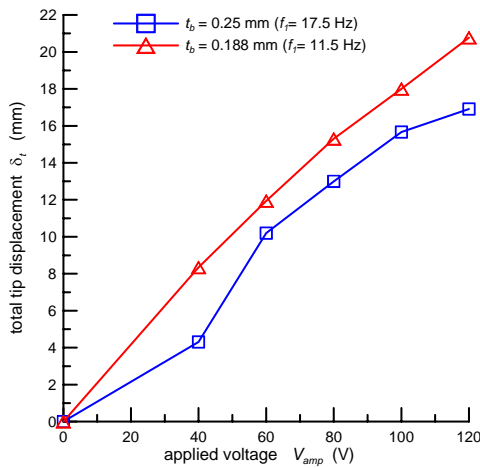
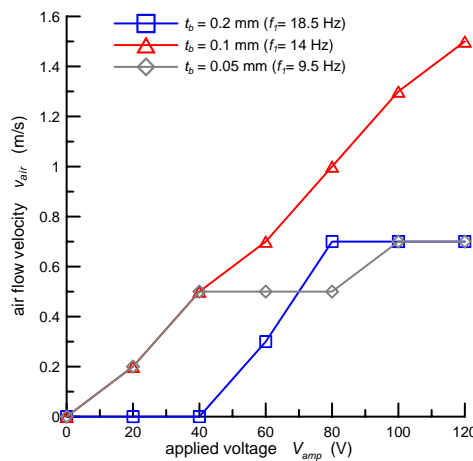

Fig. 8 Variation of blade tip displacement with applied frequency of piezoelectric fan with PET blade ($V_{amp} = 80\text{V}$)

 Fig. 9 Relationship between v_{air} and V_{amp} of piezoelectric fan with PET blade

 Fig. 12 Relationship between δ_t and V_{amp} of piezoelectric fan with steel blade

 Fig. 10 Relationship between δ_t and V_{amp} of piezoelectric fan with PET blade

 Fig. 11 Relationship between v_{air} and V_{amp} of piezoelectric fan with steel blade

As a simplification, the cantilever Euler beam model can be used to estimate the behaviors of the piezoelectric fan. The tip deflection δ of the cantilever Euler beam is [9]:

$$\delta = \frac{FL^3}{3E_y I} \quad (2)$$

where F , L , E_y , and I , are the force, length, Young's modulus and moment of inertia, respectively. In addition, according to the vibration theory, the natural frequency f_1 of the first mode shape of the Euler beam is [10]:

$$f_1 = \frac{3.516}{2\pi} \sqrt{\frac{E_y I}{mL^4}} \quad (3)$$

where m is the length density of mass. It should be noted that (2) and (3) may induce opposite design ideas for maximizing the air flow velocity. For example, larger blade thickness (larger value of I) can perform higher natural frequency, but it will induce smaller tip deflection. This paradox and complicated phenomenon cause the confusion of using (2) and (3) for designing the piezoelectric cooling fan. Figs. 9 to 12 also show this complicated phenomenon and confusion.

From above experimental results and discussions, it is difficult to find an optimal design of the piezoelectric cooling fan by the concepts of (2) and (3).

IV. EXPERIMENTAL STUDIES: COOLING PERFORMANCE

In this section, the cooling performance of the piezoelectric fan is confirmed. The dimensions of the piezoelectric fan are $L_1=60\text{mm}$, $L_2=32\text{mm}$, $L_3=36\text{mm}$, $W_b=20\text{mm}$, $W_p=10\text{mm}$, $t_b=0.25\text{mm}$, $t_p=0.3\text{mm}$, and $t_c=0.1\text{mm}$. The material used for of the blade is the PET plastics. Fig. 13 shows the experimental equipments for the cooling performance. The heater and heatsink will be cooled by the piezoelectric fan. The temperature at the measuring point is measured by the thermo-couple and thermo-meter.

Fig. 14 shows the temperature history data at the measuring point. At 600s, the piezoelectric fan is turned on and the air flow is produced. At 2000s, the temperature change of the heater is $\Delta T = -12$ °C. The piezoelectric fan proves its cooling capability for the hot device.

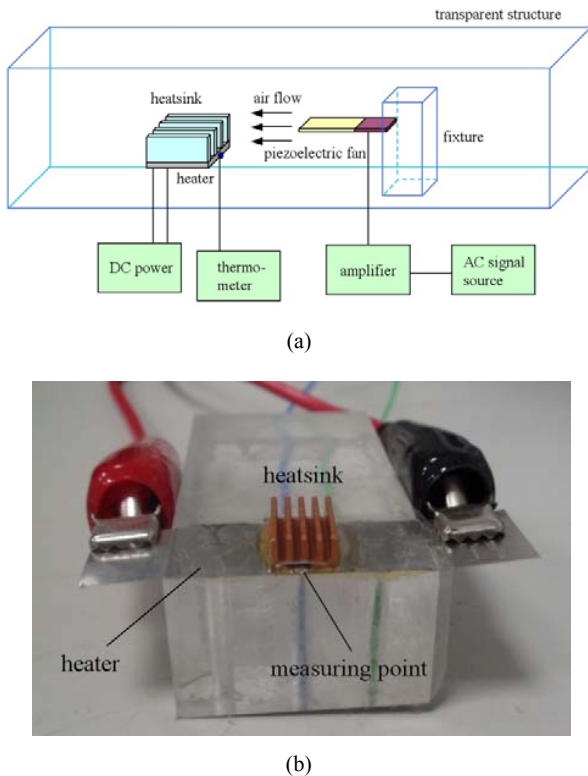

Fig. 13 Experimental equipments for cooling performance (a) layout figure (b) photo of heater and heatsink

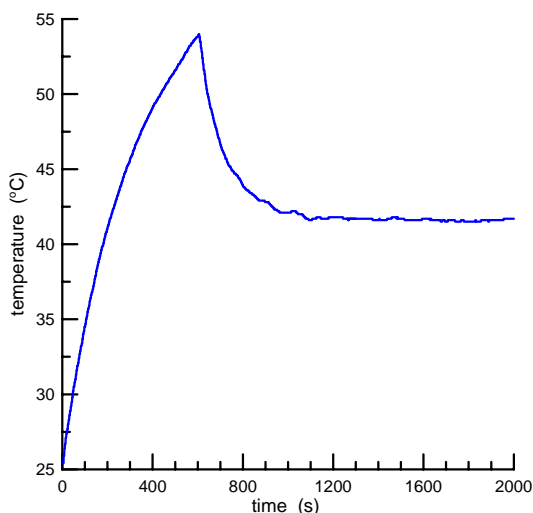

Fig. 14 Temperature versus time

V. CONCLUSIONS

Some notes on the vibration design for the piezoelectric

cooling fan have been discussed in this short paper. For this fluid-structure interaction problem, it is not easy to find the optimal design of the piezoelectric fan by the formulas of the cantilever Euler beam. It is worth creating an optimal design process in the future. However, in the design process, the larger air flow can be obtained by the trial-and-error method but it is not scientific.

ACKNOWLEDGMENTS

The authors are grateful to the Ming Chi University of Technology for the financial support under the contract number "100-Start-Academic-Research-E-01".

REFERENCES

- [1] M. Toda and S. Osaka, "Vibrational fan using the piezoelectric polymer PVF₂," *Proceedings of the IEEE*, vol. 67, pp. 1171–1173, 1979.
- [2] J.H. Yoo, J.I. Hong and W. Cao, "Piezoelectric ceramic bimorph coupled to thin metal plate as cooling fan for electronic devices," *Sensors and Actuators*, vol. 79, pp. 8–12, 2000.
- [3] T. Acikalin, S.V. Garimella, A. Raman and J. Petroski, "Characterization and optimization of the thermal performance of miniature piezoelectric fans," *International Journal of Heat and Fluid Flow*, vol. 28, pp. 806–820, 2007.
- [4] M. Kimber and S.V. Garimella, "Measurement and prediction of the cooling characteristics of a generalized vibrating piezoelectric fan," *International Journal of Heat and Mass Transfer*, vol. 52, pp. 4470–4478, 2009.
- [5] W.J. Sheu, R.T. Huang and C.C. Wang, "Influence of bonding glues on the vibration of piezoelectric fans," *Sensors and Actuators A: Physical*, vol. 148, pp. 115–121, 2008.
- [6] H.K. Ma, H.C. Su, C.L. Liu and W.H. Ho, "Investigation of a piezoelectric fan embedded in a heat sink," *International Communications in Heat and Mass Transfer*, vol. 39, pp. 603609, 2012.
- [7] J. Yang, *Analysis of Piezoelectric Devices*. Singapore: World Scientific Publishing, 2006.
- [8] T.J.C. Liu, "Fracture mechanics and crack contact analyses of the active repair of multi-layered piezoelectric patches bonded on cracked structures," *Theoretical and Applied Fracture Mechanics*, vol. 47, pp. 120–132, 2007.
- [9] J.M. Gere and B.J. Goodno, *Mechanics of Materials*. 8th Ed., Singapore: Cengage Learning, 2013.
- [10] L. Meirovitch, *Fundamentals of Vibrations*. New York: McGraw-Hill, 2001.