

Geometrically Non-Linear Axisymmetric Free Vibrations of Thin Isotropic Annular Plates

Boutahar Lhoucine, El Bikri Khalid, Benamar Rhali

Abstract—The effects of large vibration amplitudes on the first axisymmetric mode shape of thin isotropic annular plates having both edges clamped are examined in this paper. The theoretical model based on Hamilton's principle and spectral analysis by using a basis of Bessel's functions is adapted here to the case of annular plates. The model effectively reduces the large amplitude free vibration problem to the solution of a set of non-linear algebraic equations.

The governing non-linear eigenvalue problem has been linearised in the neighborhood of each resonance and a new one-step iterative technique has been proposed as a simple alternative method of solution to determine the basic function contributions to the non-linear mode shape considered.

Numerical results are given for the first non-linear mode shape for a wide range of vibration amplitudes. For each value of the vibration amplitude considered, the corresponding contributions of the basic functions defining the non-linear transverse displacement function and the associated non-linear frequency, the membrane and bending stress distributions are given. By comparison with the iterative method of solution, it was found that the present procedure is efficient for a wide range of vibration amplitudes, up to at least 1.8 times the plate thickness,

Keywords—Non-linear vibrations, Annular plates, Large vibration amplitudes.

I. INTRODUCTION

LARGE vibration amplitudes of thin structures, inducing the effects of geometrical non-linearity, are examined here. One of the fundamental characteristics of non-linear vibrations is the dependence of the frequency on the vibration amplitude. Indeed, a transverse displacement of the same order of magnitude of the structure thickness is sufficient to induce significantly this effect. Under large vibration amplitudes of thin annular plates, the governing equation of motion become non-linear and coupled. Since exact solutions are most of the time not available, recourse has been to approximate analyses.

The assumptions generally used are the separation of time and space variables and the use of an assumed space or time mode.

Although the single mode approximation permitted to obtain analytical solutions for the amplitude-frequency dependence and the non-linear forced frequency response function and to gain some understanding on the non-linear response of continuous systems, it is limited in a sense that it does not lead to any information concerning the deflection shapes amplitude

dependence, which is of crucial importance for determining the associated non-linear stress patterns, as shown in [4], [5], [7]. To remedy this insufficiency, multimodal models taking into account the modal contribution of the higher modes should be used.

In a previous work, the geometrically non-linear transverse free axisymmetric vibrations of clamped thin isotropic circular plates have been studied using a multimode model [7]. In this reference, a comprehensive study on the effect of large vibration amplitudes on the natural frequencies, the mode shapes and the associated bending and membrane stresses has been made. The model reduced the non-linear vibration problem to numerical iterative solution of nonlinear eigenvalue problem.

In attempt to contribute to the development of a sort of non-linear modal analysis theory, allowing direct and easy determination of non-linear frequencies and the associated bending and membrane stresses of thin straight structures, for the amplitude ranges of interest in practical applications, a new procedure using a simplified multimode approach is proposed in this paper. This procedure, which may be appropriate for engineering purposes or for further analytical investigations is based on the linearization of the governing non-linear eigenvalue problem, in the neighborhood of each resonance, leading to the solution of a modified linear eigenvalue problem, and a new one-step iterative technique is used to determine the basic function contribution to the non-linear mode shapes considered. It is shown that the new procedure of solution is as accurate as the iterative method of solution for a wide range of vibration amplitudes.

II. GENERAL FORMULATION

A. Introduction

The new procedure for the study of the large free vibration amplitudes of thin straight structures is applied here to the case of thin isotropic annular plates having both edges clamped by using and adapting the approach mentioned above. Before introducing the new technique of solution, a brief review of the basic theory for determination of the structure non-linear modes shapes and resonant frequencies at large vibration amplitudes is made.

B. Problem Definition

Consider a thin annular plate of a uniform thickness h with outer radius a , inner radius b , as depicted in Fig. 1. The annular plate geometry and dimensions are defined in an orthogonal cylindrical coordinate system (r, θ, z) . The plate material is

Boutahar Lhoucine and El Bikri Khalid are with the Université Mohammed V-Souissi ENSET- rabat, LaMIPI, B.P6207, Rabat Instituts, Rabat, Morocco (e-mail: hboutahar65@gmail.com, k.elbikri@um5s.net.ma).

Benamar Rhali is with the Université Mohammed V-Agdal, EMI, LERSIM, Agdal Av.Ibn Sina, Rabat, Morocco (e-mail: rbenamar@emi.ac.ma).

assumed to be homogeneous isotropic with mass density ρ , Young's modulus E and Poisson's ratio ν .

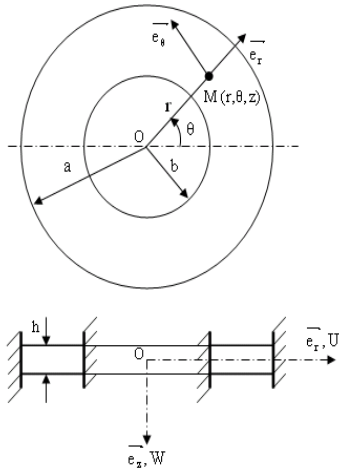

Fig. 1 Annular plate geometry, dimensions and notation

In the case of large-amplitude axisymmetric vibrations of an annular plate shown above, the displacements and the non-vanishing components of the strain tensor are similar to those given respectively by [3], [2]:

$$\overline{U}(r, z, t) = u_r(r, z, t) \overline{e}_r + u_z(r, z, t) \overline{e}_z \quad (1)$$

$$u_r(r, z, t) = u(r, t) - z(\partial W(r, t)/\partial r) \quad (2)$$

$$u_\theta(r, t) = 0, \quad u_z(r, t) = W(r, t) \quad (3)$$

$$\varepsilon_r = (\partial u_r/\partial r) + (1/2)(\partial W/\partial r)^2 - z(\partial^2 W/\partial r^2) \quad (4)$$

$$\varepsilon_\theta = (u_r/r) - (z/r)(\partial W/\partial r) \quad (5)$$

where U and W are the in-plane and out-of-plane displacements of the middle plane point $(r, \theta, 0)$ respectively, and u_r , u_θ and u_z are the displacements along r , θ and z directions, respectively.

If only transverse vibration is considered, the kinetic energy of the annular plate can be written as (neglecting the axial motion and the rotary inertia) is:

$$T = \pi \rho h \int_b^a (\partial w/\partial t)^2 r dr \quad (6)$$

The annular plate total strain energy can be written as the sum of the strain energy due to the bending denoted as V_{lin} , plus the axial strain energy due to the axial load induced by large deflection denoted as V_{nlin}

$$V = V_{lin} + V_{nlin} \quad (7)$$

$$V_{lin} = \pi D \int_b^a [(\partial w^2/\partial r^2) + 1/r (\partial w/\partial r)]^2 r dr - \pi D \int_b^a 2(1-\nu)(1/r)(\partial w/\partial r) (\partial w^2/\partial r^2) r dr \quad (8)$$

$$V_{nlin} = 3\pi D/h^2 \int_b^a (\partial w/\partial r)^4 r dr \quad (9)$$

where $D = Eh^3/12(1-\nu^2)$

The transverse displacement function is expanded as a series of basic spatial functions (the linear modes) and the time function is supposed to be harmonic:

$$w(r, t) = w_i(r) \cdot q_i(t) = a_i w_i(r) \sin(\omega t) \quad (10)$$

where the usual summation convention for the repeated indices is used. One obtains after discretization of the expressions (6), (8) and (9):

$$T = (1/2)\omega^2 a_i a_j m_{ij} \cos^2(\omega t) \quad (11)$$

$$V_{nlin} = 1/2 a_i a_j a_k a_l b_{ijkl} \sin^4(\omega t) \quad (12)$$

$$V_{lin} = 1/2 a_i a_j k_{ij} \sin^2(\omega t) \quad (13)$$

$$V = 1/2 a_i a_j k_{ij} \sin^2(\omega t) + 1/2 a_i a_j a_k a_l b_{ijkl} \sin^4(\omega t) \quad (14)$$

where m_{ij} , k_{ij} and b_{ijkl} are the mass tensor, the rigidity tensor and the non-linearity tensor, respectively, given by:

$$m_{ij} = 2\pi \rho h \int_b^a w_i w_j r dr \quad (15)$$

$$k_{ij} = 2\pi D \int_b^a (\partial w_i^2/\partial r^2)(\partial w_j^2/\partial r^2) + (\partial w_j/\partial r) r dr + 2\pi D \int_b^a (1/r^2)(\partial w_i/\partial r)(\partial w_j/\partial r) r dr + 2\pi D \int_b^a (v/r \partial w_i/\partial r \partial w_j^2/\partial r^2 + v/r \partial w_i^2/\partial r^2 \partial w_j/\partial r) r dr \quad (16)$$

$$b_{ijkl} = 6\pi D/h^2 \int_b^a (\partial w_i/\partial r)(\partial w_j/\partial r)(\partial w_k/\partial r)(\partial w_l/\partial r) r dr \quad (17)$$

The dynamic behavior of the structure is governed by Hamilton's principle, which is symbolically written as:

$$\partial \int_b^{2\pi/\omega} (V - T) dt = 0 \quad (18)$$

In which ∂ indicates the variation of the integral. Introducing the assumed series (10) into the energy condition (18) via (11) and (14) reduces the problem to that of finding the minimum of the function φ given by:

$$\varphi = \int_0^{2\pi/\omega} (1/2 a_i a_j k_{ij} \sin^2(\omega t)) dt + \int_0^{2\pi/\omega} (1/2 a_i a_j a_k a_l b_{ijkl} \sin^4(\omega t)) dt - \int_0^{2\pi/\omega} (1/2 \omega^2 a_i a_j m_{ij} \cos^2(\omega t)) dt \quad (19)$$

with respect to the undetermined constant a_i . Integrating the trigonometric functions, $\sin^2(\omega t)$, $\sin^4(\omega t)$ and $\cos^2(\omega t)$ over the range $[0, 2\pi/\omega]$, (19) leads to the following expression:

$$\varphi = (2\pi/\omega)(a_i a_j k_{ij} + (3/4)a_i a_j a_k a_l b_{ijkl} - \omega^2 a_i a_j m_{ij}) \quad (20)$$

In this expression, φ appears as a function of only the undetermined constant a_i . $i = 1, \dots, n$

Equation (18) reduces to:

$$\partial\varphi/\partial a_r = 0, \quad r = 1, \dots, n$$

Generally, and this is the case for all of the applications previously made of the present theory, the tensors m_{ij} and k_{ij} are symmetric, and the tensor b_{ijkl} is such that:

$$b_{ijkl} = b_{klij}, \quad b_{ijkl} = b_{jikl}$$

Taking into account these properties of symmetry, it appears that (18) are equivalent to the following set of nonlinear algebraic equations:

$$2a_i k_{ir} + 3a_i a_j a_k b_{ijk r} - 2\omega^2 a_i m_{ir} = 0; \quad r = 1, \dots, n \quad (21)$$

Equation (21) represents a set of n non-linear algebraic equations relating the n coefficients a_i and the frequency ω .

$$\omega^2 = (a_i a_j k_{ij} + (3/2)a_i a_j a_k a_l b_{ijkl}) / (a_i a_j m_{ij}) \quad (22)$$

which has to be substituted in (21) to obtain a system of n non-linear algebraic equations leading to the n contribution coefficients a_i ; $i = 1, \dots, n$. Adopting the solution procedure used in [4], [5], the contribution coefficient a_{r_0} of the basic function corresponding to the desired mode r_0 is first fixed, and the other basic function contribution coefficients are calculated via numerical solution of the remaining $(n - 1)$ non-linear algebraic equations

$$2a_i k_{ir} + 3a_i a_j a_k b_{ijk r} - 2\omega^2 a_i m_{ir} = 0; \quad r \neq r_0 \quad (23)$$

The values obtained for a_i , for $i \neq r_0$, are then substituted into (22) to obtain the corresponding value of $\omega_{r_0}^2$.

To obtain non-dimensional parameters, we put:

$$w_i(r) = h w_i^*(r^*), \quad r^* = r/a, \quad \alpha = b/a, \quad \omega^2/\omega^{*2} = D/\rho h a^4$$

$$m_{ij}/m_{ij}^* = 2\pi\rho a^2 h^3, \quad k_{ij}/k_{ij}^* = 2\pi D h^2/a^2,$$

$$b_{ijkl}/b_{ijkl}^* = 2\pi D h^2/a^2 \quad (24)$$

m_{ij}^* , k_{ij}^* and b_{ijkl}^* are non dimensional tensors given by:

$$m_{ij}^* = \int_{\alpha}^1 w_i^* w_j^* r^* dr^* \quad (25)$$

$$k_{ij}^* = \int_{\alpha}^1 (\partial^2 w_i^*/\partial r^{*2})(\partial^2 w_j^*/\partial r^{*2}) r^* dr^* + \int_{\alpha}^1 (1/r^{*2})(\partial w_i^*/\partial r^*)(\partial w_j^*/\partial r^*) r^* dr^* + \int_{\alpha}^1 (v/r^*)(\partial w_i^*/\partial r^*)(\partial^2 w_j^*/\partial r^{*2}) r^* dr^* + \int_{\alpha}^1 (v/r^*)(\partial^2 w_i^*/\partial r^{*2})(\partial w_j^*/\partial r^*) r^* dr^* \quad (26)$$

$$b_{ijkl}^* = 3 \int_{\alpha}^1 (\partial w_i^*/\partial r^*)(\partial w_j^*/\partial r^*)(\partial w_k^*/\partial r^*)(\partial w_l^*/\partial r^*) r^* dr^* \quad (27)$$

Substituting these equations into (22) and (23) leads to:

$$2a_i k_{ir}^* + 3a_i a_j a_k b_{ijk r}^* - 2\omega^{*2} a_i m_{ir}^* = 0 \quad r \neq r_0 \quad (28)$$

$$\omega^{*2} = (a_i a_j k_{ij}^* + (3/2)a_i a_j a_k a_l b_{ijkl}^*) / (a_i a_j m_{ij}^*) \quad (29)$$

A. Bending Stress Expressions

In the light of the assumption adopted here of zero in-plane displacement, only the bending stresses can be calculated with a good accuracy using the transverse displacement functions calculated. At the instant of maximum amplitude, i.e. $t = \pi/\omega$, the surface bending strains ϵ_{br} and $\epsilon_{b\theta}$, obtained for $z = h/2$, are given by:

$$\epsilon_{br} = -h/2 (d^2 w/dr^2); \quad \epsilon_{b\theta} = -h/2 (1/r dw/dr) \quad (30)$$

By using the classical thin plate assumption of plane stress and Hooke's law, the surface radial and circumferential bending stresses are given by:

$$\sigma_{br} = -Eh/2(1 - \nu^2) [(d^2 w/dr^2) + \nu/r (dw/dr)] \quad (31)$$

$$\sigma_{b\theta} = -Eh/2(1 - \nu^2) [(1/r) dw/dr + \nu (d^2 w/dr^2)] \quad (32)$$

In terms of the non-dimensional parameters defined in the previous section (24) to (27), the non-dimensional surface bending stresses σ_{br}^* and $\sigma_{b\theta}^*$ can be defined by:

$$\sigma_{br}^* = -1/2(1 - \nu^2) [(d^2 w^*/dr^{*2}) + \nu/r^* (dw^*/dr^*)] \quad (33)$$

$$\sigma_{b\theta}^* = -1/2(1 - \nu^2) [(1/r^*) dw^*/dr^* + \nu (d^2 w^*/dr^{*2})] \quad (34)$$

The relationship between the dimensional bending and non-dimensional bending stresses is

$$\sigma^*/\sigma = a^2/Eh^2 \quad (35)$$

This is valid for both dimensional and non-dimensional bending stresses defined by (31) to (34).

B. Methods of Solution

The set of non-linear algebraic equations (28) can be written in a matrix form as:

$$[Kl^* + Knl^*]\{A\} - \omega^{*2}[M^*]\{A\} = \{0\} \quad (36)$$

where $[M^*]$; $[Kl^*]$ and $[Knl^*]$ are the non-dimensional mass matrix, the non-dimensional linear stiffness matrix and the non-dimensional non-linear geometrical stiffness matrix, respectively. Each term of the matrix $[Knl^*]$ is a quadratic function of the column matrix of coefficients $\{A\} = [a_1, a_2, a_3, \dots, a_n]^T$; and is given by:

$$Knl_{ij}^* = (3/2) a_k a_l b_{ijkl}^* \tag{37}$$

It can be seen that when the non-linear term is neglected, the non-linear eigenvalue problem (36) reduces to the classical eigenvalue problem which is the Rayleigh–Ritz formulation of the linear vibration problem.

$$[Kl^*]\{A\} - \omega^2[M^*]\{A\} = \{0\} \tag{38}$$

In the linear case, the eigenvalue equation (38) leads to a series of eigenvalues and corresponding eigenvectors. In the non-linear case, the solution of (36) should lead to a set of amplitude-dependent eigenvectors, with their amplitude dependent associated eigenvalues. To solve the non-linear eigenvalue problem (36), incremental-iterative methods are generally used.

C. New Procedure of Solution

A new one-step iterative technique has been proposed as an alternative simple method of solution to determine the basic function contributions to the non-linear mode considered. The main idea behind this procedure is illustrated in Table III, in which data obtained via the numerical solution of the non-linear algebraic system (28) are presented for the first non-linear axisymmetric mode shape of an annular plate having both edges clamped. It can be seen from this table that the contribution coefficient a_{r_0} ($r_0 = 1$) of the basic function corresponding to the r_0^{th} mode shape, i.e. the first mode shape in the present case, remains predominant for the whole range of vibration amplitudes considered. So, the others basic function contribution coefficients (a_i ; $i \neq 1$) may be regarded as small compared to a_{r_0} , and denoted in what follows as ϵ_i . For the first non-linear mode shape, this approach is based on an approximation which consists on neglecting in the expression $a_k a_l b_{ijkl}^*$, appearing in (37), both first terms with

respect to ϵ_i , i.e. terms of the type $a_1 \epsilon_j \epsilon_k b_{1ijk}^*$, so that the only remaining term is $a_1^2 b_{11ij}^*$. This approximation is acceptable because the computed values of the non-linearity parameters b_{ijkl}^* defined in (37) are of the same magnitude. Thus, (37) becomes:

$$Knl_{ij}^* = (3/2) a_1^2 b_{11ij}^* \tag{39}$$

The non –linear eigenvalue problem (36) becomes:

$$[K^{1*}]\{A\} - \omega^2[M^*]\{A\} = \{0\} \tag{40}$$

$$\text{In which } [K^{1*}] = Kl_{ij}^* + (3/2) a_1^2 b_{11ij}^* \tag{41}$$

Thus, for a given value of the predominant first mode contribution (a_1), the rigidity matrix $[K^{1*}]$ is constant and the eigenvalue problem (36) is a linearized one. The direct solution of the linearized eigenvalue problem (36) for a specified value of (a_1), corresponding to a given maximum non-dimensional amplitude of vibration w_{max}^* , leads the value of the eigenvalue ω^{*2} (the smallest one for the first mode) and the corresponding eigenvector $\{A\}$, normalized in such a manner that its first component is precisely the specified value of (a_1).

The method consists on injecting the components of the eigenvector $\{A\} = [a_1, a_2, a_3, \dots, a_n]^T$ determined in a given iteration in the non linear term $Knl_{ij}^* = (3/2) a_1^2 b_{11ij}^*$, before performing the following iteration.

It was noticed then the convergence is obtained after a small number of iterations (less than 7 iterations for the first mode).

D. Numerical Results and Discussion

1. Determination of the Axisymmetric Linear Modes of Thin Isotropic Annular Plate Having Both Edges Clamped

In this section the Rayleigh method is used to analyze the free vibrations and determine the fundamental linear frequencies. The method is taken from [1] and [6]. In Rayleigh method, the displacement function must satisfy the geometric boundary conditions. Numerical results thus obtained are summarized in Table I. Comparing results with those in the literature validates the present analysis.

TABLE I
DIMENSIONLESS FREQUENCY PARAMETERS FOR THE ANNULAR PLATE WITH CLAMPED OUTER AND INNER EDGE (C-C) (N=0.3)

Results	Mode (m , n)	b/a			
		0.1	0.3	0.5	0.7
Leissa [1]	(0, 1)	27.3000	45.2000	89.2000	248.0000
Vera and Febbo. [6]		27.2800	45.3460	89.2500	248.4020
Present study		27.2805	45.3462	89.2508	248.4021
Leissa [1]	(1, 1)	28.4000	46.6000	90.2000	249.0000
Vera and Febbo. [6]		28.9150	46.6430	90.2300	249.1640
Present study		28.9158	46.6435	90.2303	249.1639
Leissa [1]	(2, 1)	36.7000	51.0000	93.3000	251.0000
Vera and Febbo. [6]		36.6170	51.1380	93.3210	251.4800
Present study		36.6173	51.1388	93.3212	251.4806
Leissa [1]	(3, 1)	51.2000	60.0000	99.0000	256.0000
Present study		51.2188	60.0335	98.9280	255.4438

2. Determination of the Non- Linear Mode Shapes of Thin Isotropic Annular Plate Having Both Edges Clamped

To obtain the fundamental non-linear mode shape, the first six axisymmetric linear mode shapes were used. The corresponding non-dimensional linear frequencies $(\omega_l^*)_i$ $i = 1, \dots, 6$ are given in Table II and the corresponding curves are plotted in Fig. 2.

TABLE II
NON-DIMENSIONAL LINEAR FREQUENCIES $(\omega_l^*)_i$; ASSOCIATED WITH THE AXISYMMETRIC LINEAR MODES OF A THIN ISOTROPIC ANNULAR PLATE HAVING BOTH EDGES CLAMPED ($\alpha = 0.1$) FOR $i = 1, \dots, 6$

i	1	2	3	4	5	6
$(\omega_l^*)_i$	27.28	75.36	148.21	245.48	367.17	513.26

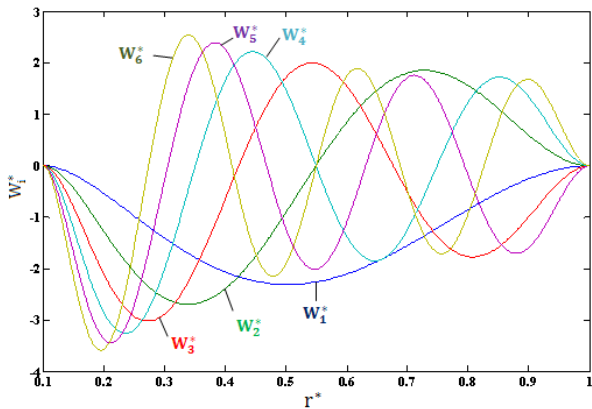

Fig. 2 Non-dimensional axisymmetric linear modes shape $w_i^*(r^*)$ of free vibration for an annular plate having both edges clamped ($\alpha = 0.1$) for $i = 1, \dots, 6$

Some computed values of a_2, \dots, a_6 , corresponding to a_1 varying from 0.005 up to 1 are given in Table III. For each solution a_1, a_2, \dots, a_6 the corresponding values of $(\omega_{nl}^*/\omega_l^*)$ and w_{max}^* varying from 0.01095 to 2.16391. a_i represents the contribution of the i^{th} basic function w_i^* . w_{max}^* is the maximum non-dimensional amplitude, and $(\omega_{nl}^*/\omega_l^*)$ is the ratio of the non-linear non-dimensional frequency parameter defined in (29) to the corresponding linear non-dimensional frequency parameter given in Table I. It can be seen from this table that the non-linear non-dimensional frequencies calculated here from the non-linear analysis for very small values of a_1 coincide exactly with the corresponding linear ones. At large vibration amplitudes, the higher order mode contributions and resonance frequencies increase with the amplitude of vibration.

The normalized first linear and non linear mode shapes are plotted in Figs. 3 (a)-(c) for various values of the maximum non dimensional amplitude w_{max}^* , it can be shown that the non linear effect increases with increasing the amplitude of vibration and appears clearly for amplitudes of the order of magnitude of the plate thickness.

TABLE III
CONTRIBUTION COEFFICIENTS TO THE FIRST NON LINEAR AXISYMMETRIC MODE SHAPE OF AN ISOTROPIC THIN ANNULAR PLATE HAVING BOTH EDGES CLAMPED ($\alpha = 0.1$), OBTAINED NUMERICALLY FROM ITERATIVE SOLUTION OF THE NON-LINEAR ALGEBRAIC SYSTEM (28)

w_{max}^*	ω_{nl}^*/ω_l^*	a_1	a_2	a_3	a_4	a_5	a_6
0.010951	1.000042	0.005	-5.4572E-9	1.2143E-8	-2.3259E-9	4.4354E-9	1.1101E-9
0.021902	1.000169	0.010	-8.2187E-8	8.3941E-8	-1.8078E-8	3.6312E-8	9.2245E-9
0.065703	1.001523	0.030	-2.2509E-6	2.2596E-6	-4.8752E-7	9.8012E-7	2.4864E-7
0.109511	1.004228	0.050	-1.0800E-8	7.3254E-9	5.5800E-9	-5.9800E-9	-1.080E-10
0.218905	1.016733	0.100	-8.1597E-5	8.2147E-5	-1.7995E-5	3.5999E-5	9.0026E-6
0.654475	1.137561	0.300	-1.8668E-3	1.9107E-3	-4.6814E-4	9.0665E-4	2.0295E-4
1.086556	1.33406	0.500	-6.7269E-3	6.9443E-3	-1.9801E-3	3.7117E-3	7.0312E-4
1.517198	1.568687	0.700	-1.4093E-2	1.4435E-2	-4.7333E-3	8.7169E-3	1.3818E-3
1.948132	1.823504	0.900	-2.3064E-2	2.3207E-2	-8.5092E-3	1.5599E-2	2.0866E-3
2.163913	1.955929	1.000	-2.7935E-2	2.7820E-2	-1.0673E-2	1.9584E-2	2.4190E-3

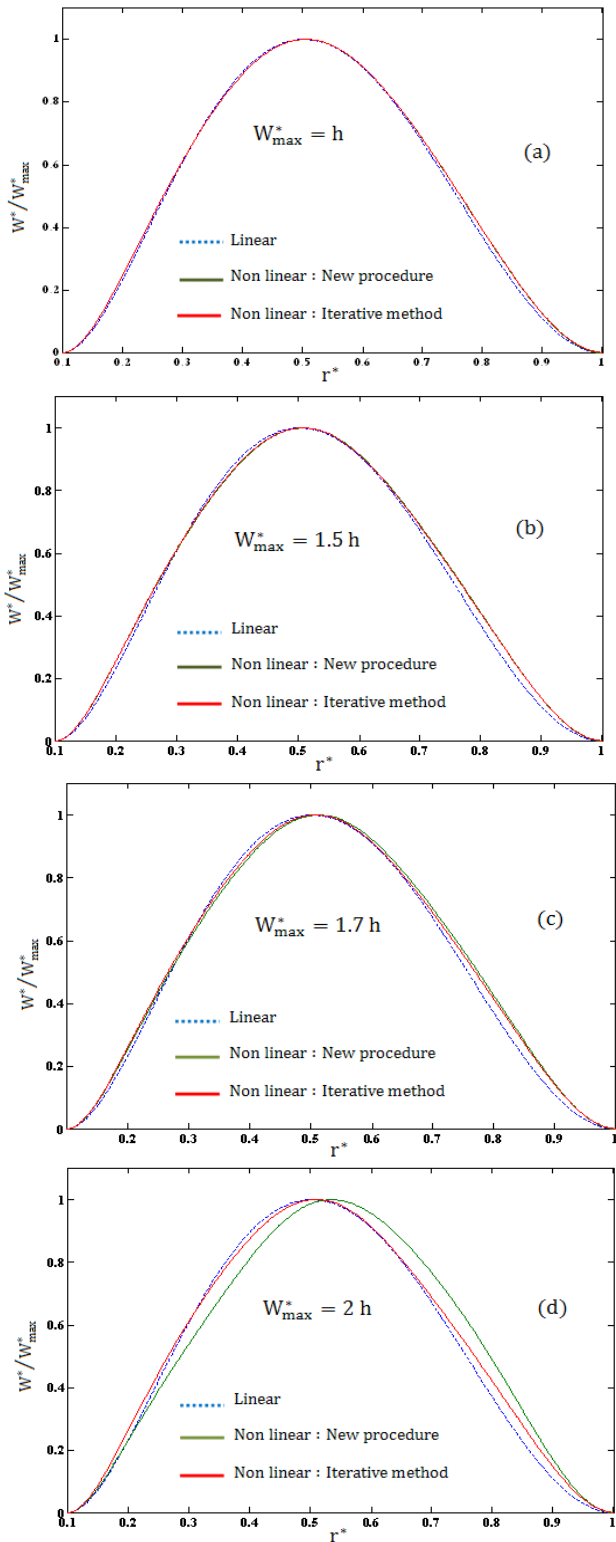

Fig. 3 Normalized fundamental first linear and non linear axisymmetric mode shape of an annular plate having both edges clamped at various non-dimensional amplitudes (a) : $W_{max}^* = 1$, (b) : $W_{max}^* = 1.5$, (c) : $W_{max}^* = 1.7$, (d) : $W_{max}^* = 2$

To have an accurate conclusion concerning the limit of validity of the new procedure in engineering applications, a criterion was adopted, based on the effects of the assumptions made regarding physical quantities, such as the non-linear frequency and the maximum bending stresses at the clamped edges of the annular plate. It may be seen from Fig. 4 that the normalized fundamental non-linear mode shape obtained by the new procedure is in excellent agreement with that obtained by the iterative method of solution for maximum non-dimensional vibration amplitude up to 1.7.

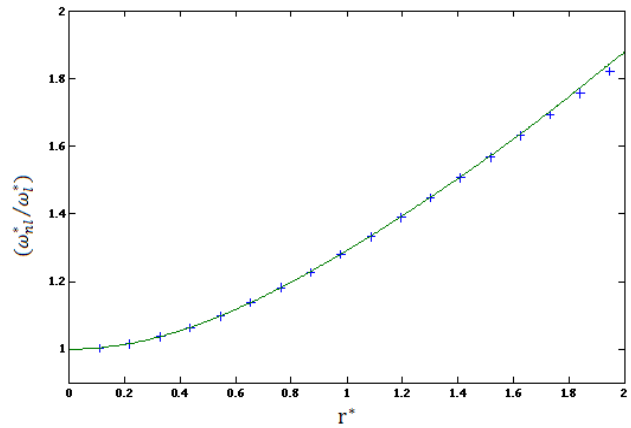

Fig. 4 Comparison of the non-dimensional frequency ratio of the two methods of solution ($\alpha = 0.1$)

The results concerning the radial and circumferential bending stresses distribution associated with the first non-linear mode shape at the clamped edges Figs. 6 and 8 are in good argument with those obtained by iterative method of solution for Poisson ratio $\nu = 0.3$.

TABLE IV
NON-DIMENSIONAL FREQUENCY RATIO (ω_{nl}^*/ω_l^*) OF AN ANNULAR PLATE HAVING BOTH EDGES CLAMPED ($\alpha = 0.1$)

W_{max}^*	Iterative solution	New procedure solution	Deviation (%)
0.1	1.003525	1.003538	0.0012954
0.3	1.031128	1.031227	0.0096011
0.5	1.083320	1.083628	0.0284311
0.7	1.155483	1.156044	0.0485511
0.9	1.242731	1.243572	0.0676735
1.0	1.290690	1.291674	0.0762383
1.3	1.447041	1.448688	0.1138185
1.5	1.558859	1.561935	0.1973238
1.7	1.674949	1.682810	0.4693277
1.8	1.734279	1.746996	0.7332730
1.9	1.794350	1.813238	1.0526374
2.0	1.855086	1.878057	1.2382714

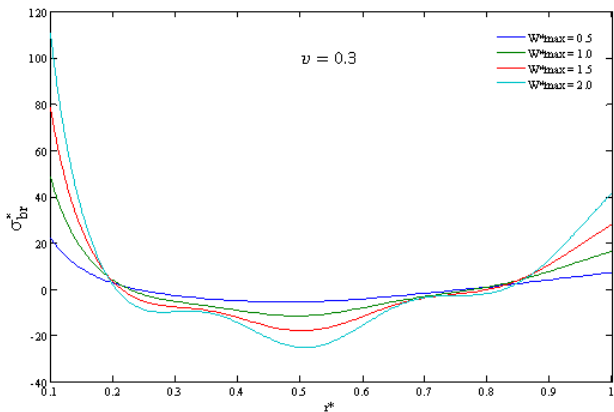

Fig. 5 Effect of large vibration amplitudes on the non-dimensional radial bending stress associated with the first non-linear axisymmetric mode shape of an annular plate having both edges clamped Iterative solution ($\alpha = 0.1, \nu = 0.3$)

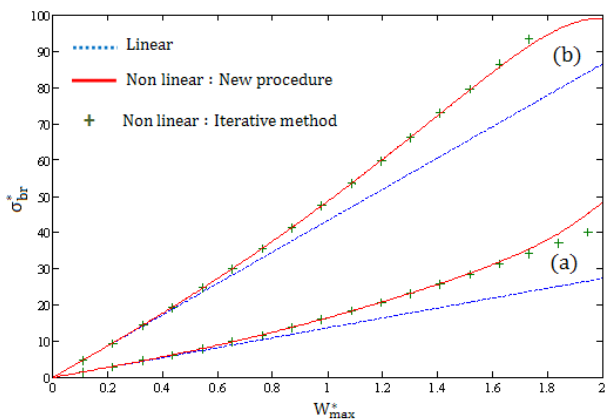

Fig. 6 Comparison of the non-dimensional radial bending stress associated with the first non-linear axisymmetric mode shape of an annular plate having both edges clamped ($\alpha = 0.1, \nu = 0.3$) (a) : at the outer edge (b) : at the inner edge

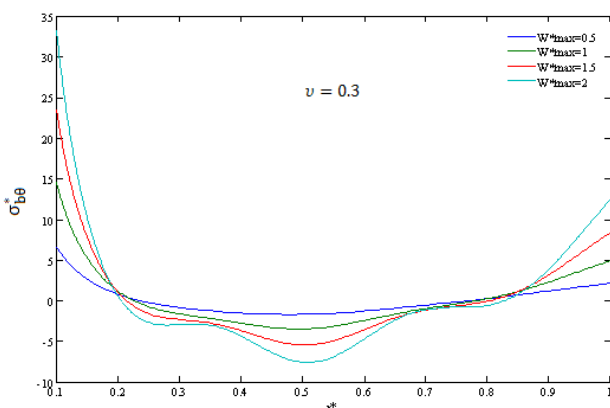

Fig. 7 Effect of large vibration amplitudes on the non-dimensional circumferential bending stress associated with the first non-linear axisymmetric mode shape of an annular plate having both edges clamped Iterative solution ($\alpha = 0.1, \nu = 0.3$)

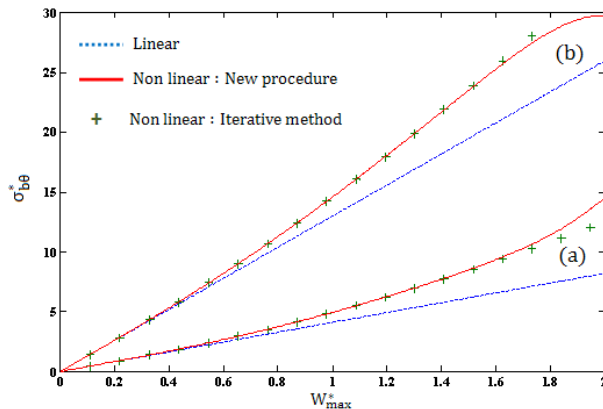

Fig. 8 Comparison of the non-dimensional circumferential bending stress associated with the first non-linear axisymmetric mode shape of an annular plate having both edges clamped ($\alpha = 0.1, \nu = 0.3$) (a) : at the outer edge (b) : at the inner edge

E. Conclusions

The simple multi-mode theory for the geometrically non-linear free vibrations of thin straight structures, based on the linearization of the governing non-linear eigenvalue problem in the neighborhood of each resonance, has been developed here for thin isotropic annular plates having both edges clamped.

The new procedure allows direct and easy determination of the non-linear modes shapes, the non-linear frequencies and the associated bending stresses. In the case of the fundamental non-linear mode of an annular plate having both edges clamped; the numerical results obtained by this technique show that the present approximate theory is valid for vibration amplitudes at least up to 1.8 times the plate thickness.

REFERENCES

- [1] A. W. Leissa. Vibration of plates. 1969 Office of Technology Utilization. Washington.
- [2] C.L. Huang, B.E. Sandman, 1971 Large amplitude vibrations of a rigidity clamped circular plate, International Journal of non-linear Mechanics 6, 451-468.
- [3] J.N. Reddy, C.L. Huang, I.R. Singh, 1981 Large deflections and large amplitude vibrations of axisymmetric circular plates, International Journal for Numerical Methods in Engineering 17, 527-541.
- [4] R. Benamar, M.M.K. Bennouna and R.G. White, 1991. The effects of large vibration amplitudes on the mode shapes and natural frequencies of thin elastic structures. Part I: Simply supported and clamped-clamped beams, Journal of Sound and Vibration 149 (2), 179-195.
- [5] R. Benamar, M.M.K. Bennouna and R.G. White, 1993. The effects of large vibration amplitudes on the mode shapes and natural frequencies of thin elastic structures. Part II: Fully clamped rectangular isotropic plates, Journal of Sound and Vibration 164 (2), 295-316.
- [6] S. A. Vera, M. Febbo, C. A. Rosit, A. E. Dolinko. 2002. Transverse vibrations of circular annular plates with edges elastically restrained against rotation, used in acoustic underwater transducers. Ocean Engineering 29,1201-1208.
- [7] M. Haterbouch, R. Benamar, 2003. The effects of large vibration amplitudes on the axisymmetric mode shapes and natural frequencies of clamped thin isotropic circular plates, part I: iterative and explicit analytical solution for non-linear transverse vibrations, Journal of Sound and Vibration 265, 123-154.