

Control Strategy of SRM Converters for Power Quality Improvement

Yogesh Pahariya, Rakesh Saxena, Biswaroop Sarkar

Abstract—The selection of control strategy depends on the converters of the drive including power, speed, performance and the possible system costs. A number of attempts were therefore made in recent times to develop novel power electronic converter structures for SRM drives, based on the utilization. Many of the converters with variable speed drives have no input power factor correction circuits. This results in harmonic pollution of the utility supply, which should be avoided. The effect of power factor variation in terms of harmonic content is also analyzed in this study. The proposed topologies were simulated using MATLAB / Simulink software package and the results are obtained.

Keywords—Harmonic Pollution, Power Electronic Converter, Power Quality, Simulation.

I. INTRODUCTION

THE choice of control strategy for SRM is dependent on the requirement of particular control applications. This required the ground work for development of control strategy. This includes the mathematical model, converter design, position sensing etc. Normally control strategies are applicable in the areas of

- Position sensor information.
- Speed control using PI, PID, Sliding mode controller, Fuzzy logic control etc.
- Converter/inverter design including power quality control.
- Torque ripples minimization.
- Reduction of acoustic noise.
- Current controller like PWM current controller, Hysteresis current controller etc.
- Fuzzy logic controller for desired operation.

The SRM draws a pulsating ac line current, resulting in low power factor and high harmonic line current. The switching of the phase winding is done by power converter and the input current becomes distorted. This will reduce the quality of the input current waveform. With increasing demand for better power quality, this approach is no longer suitable for high performance SRM drive. The best way to obtain a high power factor is the use of a power factor correction circuit (PFC) with SRM drive [1].

SRM drives are normally supplied from a stable dc link voltage. If a simple rectifier and a large dc-link capacitance produce the dclink voltage, the associated harmonics can exceed the limits given in the existing norms at relatively low

Dr. Yogesh Pahariya is with the Technocrats Institute of Technology and Science, Bhopal, (MP), India (e-mail: ypahariya@yahoo.com).

Dr. Rakesh Saxena and Dr. Biswaroop Sarkar are with the Shri G. S. Institute of Technology and Science, Indore, (MP), India (e-mail: rakeshkusaxena@gmail.com, b.sarkar@usa.net).

powers. Some sort of PFC is, therefore, needed to meet these norms. Quite often, this makes the SRM solution too expensive to be considered further. Though, SRM drive has these drawbacks, it is chosen for high performance applications based on its improved features like efficiency, dynamic response and four quadrant operation. The energy saving and the power factor improvement to maintain the input current sinusoidal is also important. The conventional methods to reduce the harmonic current in loads are by increasing number of steps in an inverter, changing the step magnitude, suitably switching the inverter, changing the size and moving of the capacitors. The modern methodology to reduce the harmonics in the system is to use filtering techniques. Passive filters and active filters are the two types of filtering methods. In active filtering methods, boost cell type, switched capacitor filter type, inverter type methods are used to reduce the harmonics in the system [2].

This paper has discussed the control strategy for improving the power quality of different types of converter using various harmonic reduction techniques. The simulation results have been presented. Therefore harmonic injected in the ac mains are negligible and hence pollution level of supply system is brought down to a permissible limit.

II. POWER QUALITY

A perfect power supply would be one that is always available, within voltage and frequency tolerances, and has a pure noise free sinusoidal wave shape. The harmonic frequencies are integral multiples of the fundamental supply frequency. The harmonic current causes problems in installation. When these currents flow back into the supply impedance at the point of common coupling, a harmonic voltage is developed. Ensuring good power quality initial design, effective correction equipment, co-operation with the supplier, frequent monitoring and good maintenance are necessary.

The distortion in the quality of supply power can be introduced /enhanced at various stages. Some of the primary sources of distortion [3] can be power electronic devices, office automation equipments, arcing devices, large motor starting, electromagnetic radiations etc. Harmonic currents cause problems both on the supply system and within the installation.

(i) Harmonic problems within the installation

Problems caused by harmonic currents:

- overloading of neutrals
- overheating of transformers
- Nuisance tripping of circuit breakers

- over-stressing of power factor correction capacitors
- Skin effect

Problems caused by harmonic voltages:

- Voltage distortion
 - zero-crossing noise
- (ii) Problems caused when harmonic currents reach the supply

The supply has source impedance and harmonic load currents give rise to harmonic voltage distortion on the voltage waveform. The distorted load current drawn by the non-linear load causes a distorted voltage drop in the cable impedance. The resultant distorted voltage waveform is applied to all other loads [1].

III. SRM CONVERTERS

A number of power electronic converter circuits exist for Switched Reluctance Machines, which are generally suits the various SRM configurations like 6/4, 8/6 etc. The phase independence and unipolar current requirement have invented wide variety of converters. For each stroke of the motor, the electronic converter for a Switched Reluctance Motor is required to provide a positive voltage loop to increase the flux in the phase winding. It must have the ability to reduce the applied voltage if the desired current level is reached. Further it must apply a negative voltage at turn off, which referred to as a negative voltage loop [4]. Some functional requirement of SRM converter which should ideally meet is as follows:

1. Needs to control the voltage applied to the winding at low speed, so as to limit the winding current; either voltage or current PWM control can be used.
2. Sufficiently high forcing voltage at each operation point so that the current is injected sufficiently quickly into the winding. This requirement is critical at high speed since the time available is less.
3. High demagnetizing voltage as possible in order to shorten the current tail, thus avoiding negative torque and/or permitting an extension of dwell angle.
4. It have to provide independent control of phase current in motors having current overlap, so that energy can be supplied to one phase while extracting it simultaneously from the other phase
5. Efficient energy recycling during a demagnetizing interval. This is an important requirement for the cyclical energy exchange between the converter and the motor.
6. It should isolate the ac network from the current pulses caused by the motor.

As torque is independent of the direction of the current, the flux linkage and the current, as well as the topology of converter circuit has a unipolar mode of operation which permits the simpler form of converter. The selection of a converter, in most of the cases, depends upon the application. The performance evaluations of following Switched Reluctance drive converters are simulated.

- Asymmetrical converter
- Suppression resistor converter.
- Bifilar converter.

- Voltage boosting converter (parallel capacitor and series capacitor).
- Sequential phase voltage boosting converters.

A. Asymmetrical Converter

The basic converter of the Switched Reluctance Motor is shown in Fig. 1. This converter circuit is known as Half Bridge converter or classic converter [4]. It has three stages Magnetization, Freewheeling, Forced demagnetization

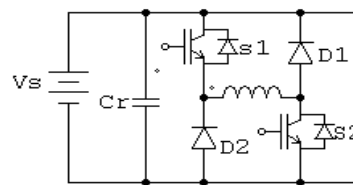

Fig. 1 Asymmetric Converter

Apart from single-pulse operation, the converter is capable of operating in pulse width modulation (PWM) mode for regulation of magnitude and wave shape of phase current. PWM operation is necessary to control the speed and torque of the SRM. During the low period of the PWM pulse, if both switches are turned off, then it results in hard-chopping operation. If only one of the switches is turned off, then soft-chopping operation takes place and phase current freewheels through the ON device [5].

B. Suppression Resistor Converter

The complete circuit of the suppression resistor topology is shown in Fig. 2 for a three-phase SRM drive [6]. Only one dump resistor and snubber circuit are necessary. Since all the switches share a common point, only one power supply is necessary for all the gate drive circuits. The current through the freewheeling diode and the power dissipated in the suppression resistor are functions of the resistance in the freewheeling path and the value of the snubber capacitor.

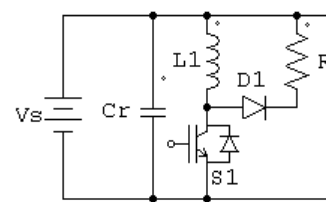

Fig. 2 Suppression Resistor Converter

C. Bifilar Converter

The energy stored in the magnetic field of the phase winding can be transferred to a closely coupled second winding. From there, the energy can be returned to the dc link or used to energize another phase winding. The magnetic recovery component is improving the performance of the system. The disadvantages are that the coupling is never

perfect in such systems, and so such circuits require the use of snubber circuits [7].

The complete circuit of a bifilar converter is shown in Fig. 3. It has an extra winding in each phase of the motor in order to recover the energy from the off going phases during commutation.

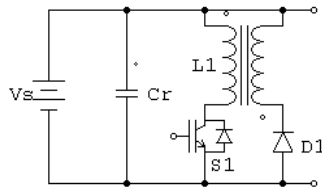

Fig. 3 Bifiller Converter

D. Voltage Boosting Converter (Parallel Capacitor)

The parallel dc-link voltage-boosting converter is shown in Fig. 4. It consists of a capacitor and diode added to a single or poly-phase winding converter of the bifilar in asymmetric half bridge or shared switched asymmetric half-bridge types. The boost capacitor increases the turn-on and turn-off voltage applied for part of the motoring stroke. All the semiconductor devices except Da must be rated for the boost voltage (or twice the boost for the bifilar converter) plus transients. For the series version of the dc-link voltage-boost topology, the voltage on the boost capacitor Cb is reduced, allowing for the use of a smaller cheaper component [7].

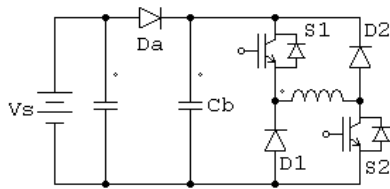

Fig. 4 Voltage Boosting Converter (Parallel Capacitor)

E. Voltage Boosting Converter (Series Capacitor)

The circuit shown in Fig. 5 is modified from the classical bridge converter by adding Da and Cb to achieve voltage boosting capability. Its operation is briefly introduced as follows:

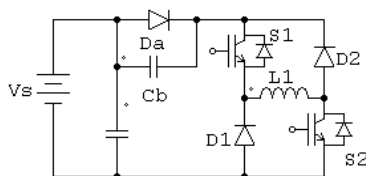

Fig. 5 Voltage Boosting Converter (Series Capacitor)

Mode 1: S1 and S2 being turned on simultaneously

Mode 2: The voltage across capacitor Cb is discharged and decreased down to zero, the diode Db will conduct naturally. Then, the winding is excited by Vs.

Mode 3: Freewheeling mode.

Mode 4: The demagnetized winding energy

Since the stored energy of the de-magnetized out-going winding also charges the incoming phase winding, the voltage boosting capability of boost converter is limited [6].

F. Sequential Phase Voltage-Boosting Converter

The sequential phase voltage-boosting converter is similar in function to a series auxiliary rail boost converter, but has a boost capacitor and a blocking diode per phase winding [7]. The typical circuit diagram is shown in Fig. 6.

In this section procedure of power quality measurement conducted on the input port of the motor controller. The power quality measurements are conducted by simulating the converters.

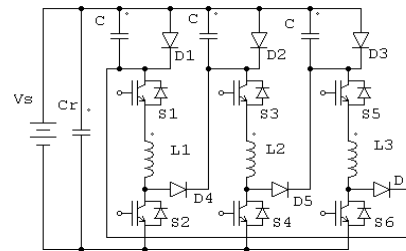

Fig. 6 Sequential Boost Converter

IV. SIMULATION OF SRM CONVERTER CONTROL STRATEGY

A standard 3 phase 6/4 switched reluctance motor is tested with different power converters. The details of construction and design parameter are mentioned in Table I.

TABLE I
SR MOTOR RATING

3 phase stator /rotor poles	6/4
Stator pole arc	33.12 degree
Rotor pole arc	37.8 degree
Phase resistance	4.79 ohms
Stator OD	71.7mm
Stack length	50.8 mm
Max inductance La	118.0 mH
Min. inductance Lu	14.66mH
Ratio La/Lu	8.049
Imax	6A
Irms	3.46A
Rated Torque	0.7Nm
Rated Speed	800rpm
Dc link voltage	70V

The simulations of various converters are performed on MATLAB/SIMULINK as shown in Fig. 7. The parameters compare for converter are flux, current (maximum and average), average torque and speed with the supply voltage of 70V.

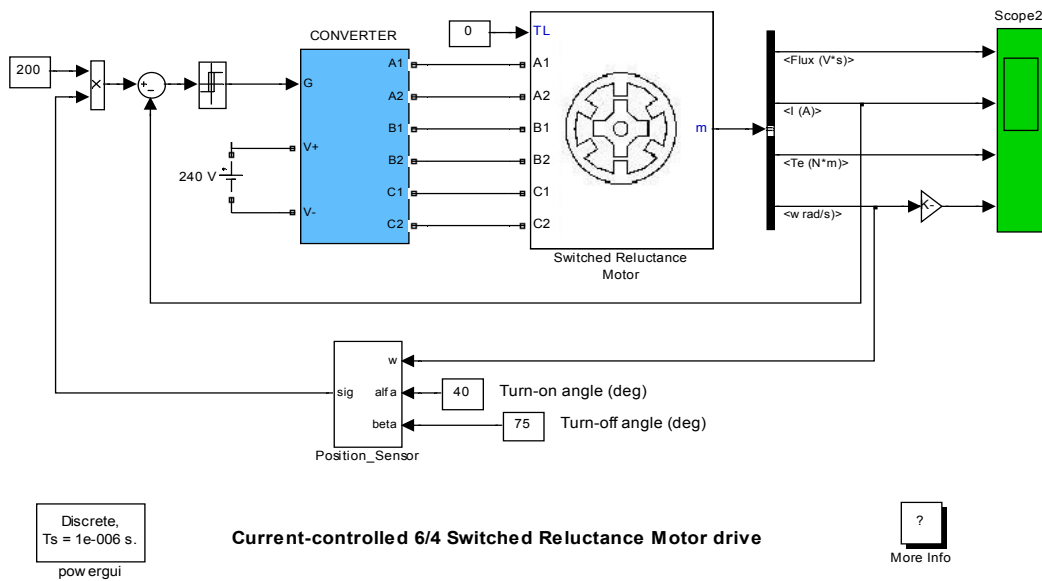

Fig. 7 Simulink model of 6/4, Switched Reluctance Motor

This SRM model is based on the measured magnetization curves. The motor is fed by a three-phase asymmetrical power converter as shown in Figs. 8 (a) and (b) which is the subsystem of main model.

Subsystem has three phases, each of which consists of two IGBTs and two free-wheeling diodes. During conduction periods, the active IGBTs apply positive source voltage to the stator windings to drive positive currents into the phase windings. During free-wheeling periods, negative voltage is applied to the windings and the stored energy is returned to the power DC source through the diodes. The fall time of the

currents in motor windings can be thus reduced. By using a position sensor attached to the rotor, the turn-on and turn-off angles of the motor phases can be accurately imposed. This switching angle can be used to control the developed torque waveforms. The phase currents are independently controlled by three hysteresis controllers which generate the IGBTs drive signals by comparing the measured currents with the references. The IGBTs switching frequency is mainly determined by the hysteresis band. The schematic simulation diagram for power quality measurement in converter control strategy is shown in Fig. 9.

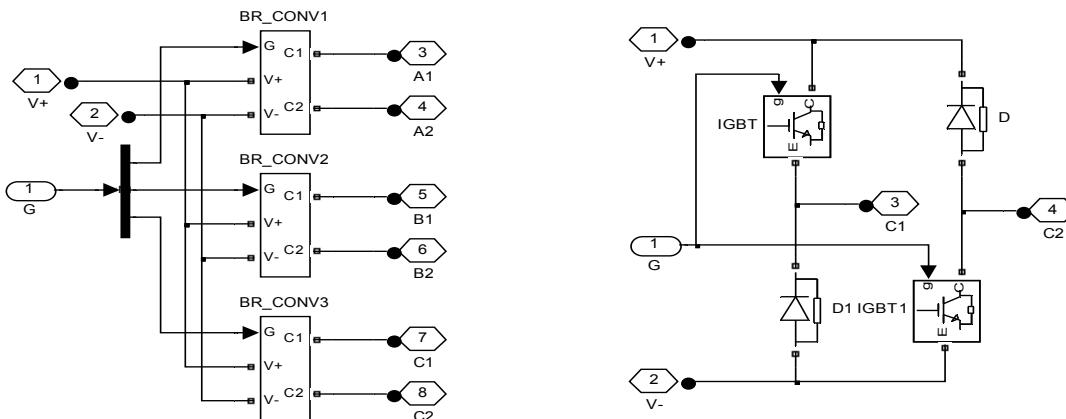

Fig. 8 (a) Sub system of Converter model (b) Connection of one phase

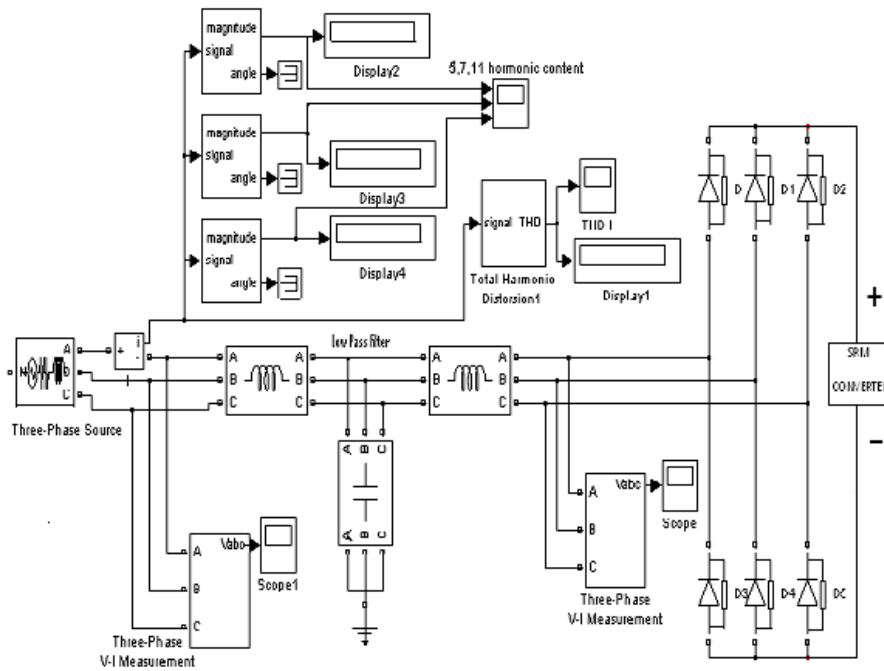

Fig. 9 Simulink Model of Converter Control strategy

V. ANALYSIS OF POWER QUALITY MEASUREMENTS

The power quality measurement has conducted through Simulink modeling of converters. The set of observations are 5th, 7th, 11th order of harmonics and Total Harmonic Distortion (THD). All current waveforms of particular harmonic has represented in single graph for all six types of converters.

A. Power Quality of SRM Converter without Harmonics Reduction Techniques

The SRM converters are directly fed from rectified DC Supply. The simulation results are shown in Figs. 10 to 13 and mentioned in Table II.

TABLE II
SIMULATION RESULTS WITHOUT HARMONICS REDUCTION TECHNIQUES

S. No.	Type of converter	5th	7th	11th	THD I
1	Asymmetric converter	16.76	5.587	4.716	47.06%
2	Dissipative converter	44.78	27.19	17.0	42.09%
3	Bifilar converter	21.74	10.08	9.423	41.7%
4	Voltage Boosting series capacitor converter	16.24	4.615	4.43	48.1%
5	Voltage Boosting parallel capacitor converter	16.27	4.48	4.631	48.98%
6	Sequential phase voltage boosting converter	20.95	11.11	8.44	49.06%

The 5th, 7th, 11th harmonic currents in dissipative converter are highest and lowest in voltage boosting series capacitor converter. The THD in all converters is ranging 40% to 50%. The sequential phase voltage boosting converter has highest THD.

B. Power Quality of SRM Converter with Star Delta Transformer

The converter circuits are connected with star delta transformer at input side. The star delta transformer winding is providing 30 degrees phase shift between them. The magnitude of the harmonics is significantly reduced by the use of twelve-pulse bridges. This is effectively two six-pulse bridges rectifier. The simulation results are shown in Figs. 14 to 17 and mentioned in Table III.

TABLE III
SIMULATION RESULTS WITH STAR DELTA TRANSFORMER

S. No.	Type of converter	5th	7th	11th	THD I
1	Asymmetric converter	2.318	2.118	9.239	4.97%
2	Dissipative converter	6.147	6.805	54.91	20.92%
3	Bifilar converter	1.525	1.012	10.57	3.79%
4	Voltage Boosting series capacitor	6.397	33.32	9.601	60.79%
5	Voltage Boosting parallel capacitor	1.464	7.585	4.802	62.75%
6	Sequential phase voltage boosting	13.08	27.68	9.606	26.24%

The 5th harmonic current in sequential phase voltage boosting converter is highest, while minimum in voltage boosting parallel capacitor converter. The 7th harmonic current is highest in voltage boosting series capacitor converter and minimum in bifilar converter. The 11th harmonic current is highest in dissipative converter and minimum in voltage boosting parallel capacitor converter. The THD is highest in voltage boosting parallel capacitor converter and minimum in bifilar converter. This harmonic reduction technique is useful for asymmetric converter and bifilar converter.

C. Power Quality of SRM with Low Pass Filter

The converter circuits are connected with low pass filter at input side. The design values of L & C are mentioned in Table IV and 'T' configuration is used in all converter circuits.

TABLE IV
DESIGN VALUES OF L & C FOR LOW PASS FILTER

S.No.	Type of converter	L in H	C in F
1	Asymmetric converter	0.114×10^{-6}	39.297×10^{-3}
2	Dissipative converter	0.110×10^{-6}	40.808×10^{-3}
3	Bifilar converter	0.116×10^{-6}	38.583×10^{-3}
4	Voltage Boosting series capacitor	0.052×10^{-6}	86.615×10^{-3}
5	Voltage Boosting parallel capacitor	0.114×10^{-6}	39.297×10^{-3}
6	Sequential phase voltage boosting	0.115×10^{-6}	39.261×10^{-3}

The low pass filter section can only allow passage of signal through it till the signal frequency is at lower magnitude. At high frequency, the inductive reactance in series arm also increases to a very high value rendering the blockage of the input signal. The low pass filter is satisfactory for increasing frequencies till the voltage gain is 0.707p.u. [8]. The simulation results are shown in Figs. 18 to 21 and mentioned in Table V.

The 5th, 7th and 11th harmonic current of the bifilar converter is high as compare to all other converter. The 5th, 7th and 11th harmonic content of all other converters are nearly same. The magnitude of the Total Harmonic Distortion of the sequential phase voltage boosting converter is very high and pulsating in nature.

TABLE V
SIMULATION RESULTS WITH LOW PASS FILTER

S.No.	Type of converter	5th	7th	11th	THD I
1	Asymmetric converter	5.672	1.15	0.2061	0.599%
2	Dissipative converter	7.51	2.91	0.6161	1.771%
3	Bifilar converter	14.79	2.292	0.7176	1.132%
4	Voltage Boosting series capacitor	5.39	1.307	.02097	0.645%
5	Voltage Boosting parallel capacitor	4.187	0.6134	0.1885	0.67%
6	Sequential phase voltage boosting	7.029	1.282	0.2856	16.47%

The Total harmonic Distortion of all other converters are nearly same and THD of Asymmetric converter is very low for Asymmetric, voltage boosting series capacitor and voltage boosting parallel converters are suitable for SRM Drives with low pass filter technique for reduction of harmonics content which are present in the line due to switching of converters.

D. Power Quality of SRM with Low Pass Filter + Star Delta Transformer

The converter circuits are connected with star delta transformer and low pass filter at input side. The simulation results are shown in Figs. 22 to 25 and mentioned in Table VI.

The magnitude of the 5th, 7th, 11th harmonics and THD produced by voltage boosting series capacitor converter and voltage boosting parallel capacitor converter is very high. Only bifilar converter has minimum of magnitude of 5th, 7th, and 11th order harmonics presence on the supply system,

therefore Bifilar converter is much suitable from the view of power quality.

TABLE VI
SIMULATION RESULTS WITH LOW PASS FILTER + STAR DELTA TRANSFORMER

S.No.	Type of converter	5th	7th	11th	THD I
1	Asymmetric converter	0.232	0.1533	0.950	1.263%
2	Dissipative converter	0.3084	1.284	1.023	1.26%
3	Bifilar converter	0.009358	0.01782	1.759	0.87%
4	Voltage Boosting series capacitor	37.02	33.6	9.722	52.14%
5	Voltage Boosting parallel capacitor	36.61	18.97	13.65	67.68%
6	Sequential phase voltage boosting	0.3434	0.2556	1.829	22.17%

VI. CONCLUSION

The comparative power quality performance of SRM converters is mentioned in Table VII. The application of control strategy for improvement of power quality indicates that same control strategy is gives variation of performance for individual converters. The negative results are indicating the increase of THD and harmonic components.

In the asymmetric converter LC Filter and YΔ + LC Filter can be used. These techniques give the reduction in THD on the supply system of 98.7% and 97.3% respectively. By the use of YΔ + LC filter technique the cost of the installation will be high. The L-C Filter technique increases the harmonic voltage drop across source impedance and across the inductor used. Due to which less harmonic voltage appear across the load. Due to increase in impedance of the circuit at higher frequency the magnitude of the harmonic current reduce, but harmonic current still flow in the line.

TABLE VII
COMPARATIVE POWER QUALITY PERFORMANCE OF SRM

S. No.	Type of converter	Star Delta Transformer	LC Filter	YΔ + LC Filter
1	Asymmetric converter	89%	98.7%	97.3%
2	Dissipative converter	50%	95.7%	97%
3	Bifilar converter	90.77%	97%	97.8%
4	Voltage Boosting series capacitor	(-) 26.3%	98.6%	(-) 8.4%
5	Voltage Boosting parallel capacitor	(-) 28.16%	98.6%	(-) 38.23%
6	Sequential phase voltage boosting	46.51%	66.4%	54.48%

The Dissipative converter can be used with (YΔ +LC Filter) technique, which if cost is no matter; it gives reduction of THD 97% and the reductions of THD 95% in case of LC filter. This technique is also suitable for above converters.

The Bifilar converter are performed almost same with all types of harmonic reduction techniques.

For the Voltage Boosting series capacitor converter and Voltage Boosting parallel capacitor converter only LC Filter technique is suitable because other technique increases the THD. The LC Filter technique gives the reduction in THD about 98%.

For Sequential phase voltage boosting converter, (YΔ +LC Filter) technique is good, it gives reduction in THD about 54% with increase in cost of installation. The better result can be

obtained by the use of LC Filter technique with low cost of installation.

The above Analysis for the converters and harmonics elimination techniques in respect of power quality, the best results are obtained by Asymmetric converter and bifilar converter with the use of Y- Δ Transformer and Y Δ +LC Filter

techniques, out of these two technique only Asymmetric converter with Y- Δ Transformer technique is best suited. The Asymmetric converter has low cost, simple circuit, simple control strategy in comparison to bifilar converter where the extra winding is used to feed back the energy stored in phase winding to the source.

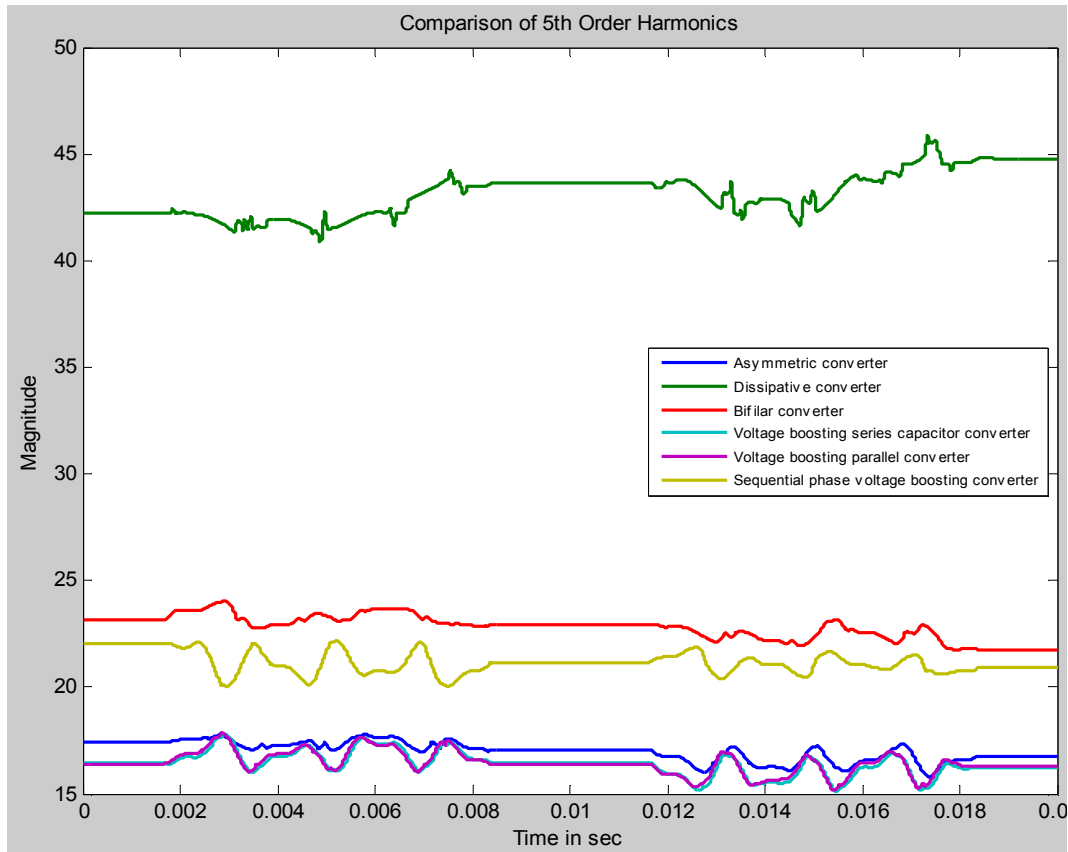

Fig. 10 5th Order Harmonics without Harmonic Reduction Techniques

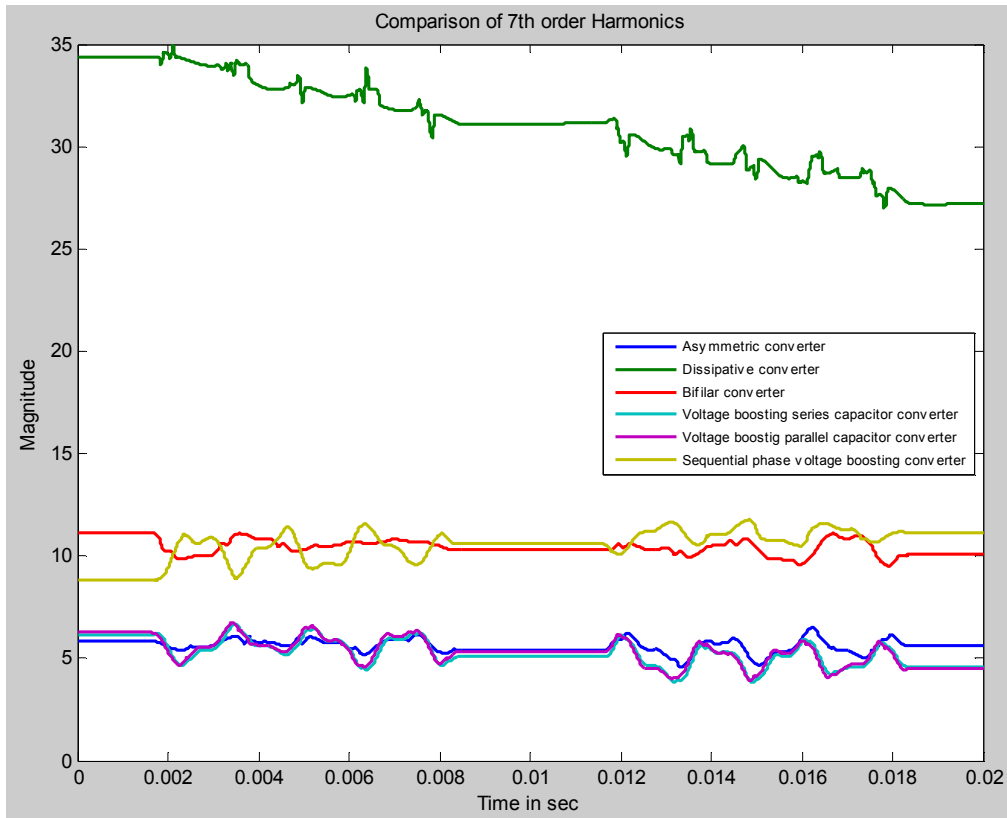

Fig. 11 7th Order Harmonics without Harmonic Reduction Techniques

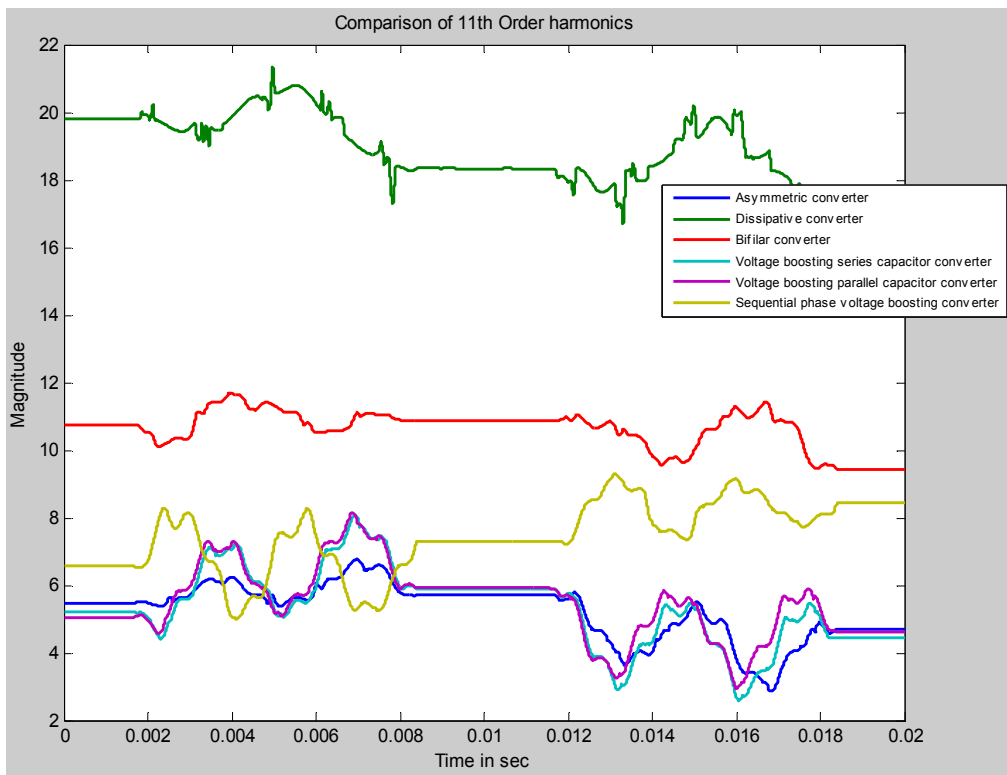

Fig. 12 11th Order Harmonics without Harmonic Reduction Techniques

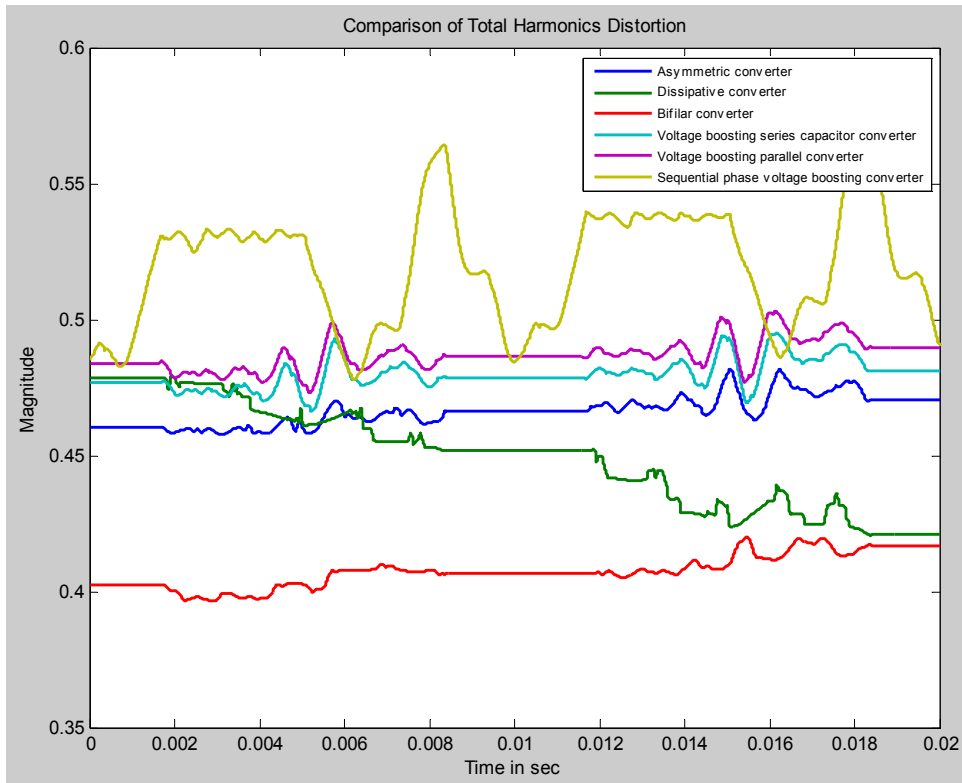

Fig. 13 Total Harmonic Distortion without Harmonic Reduction Techniques

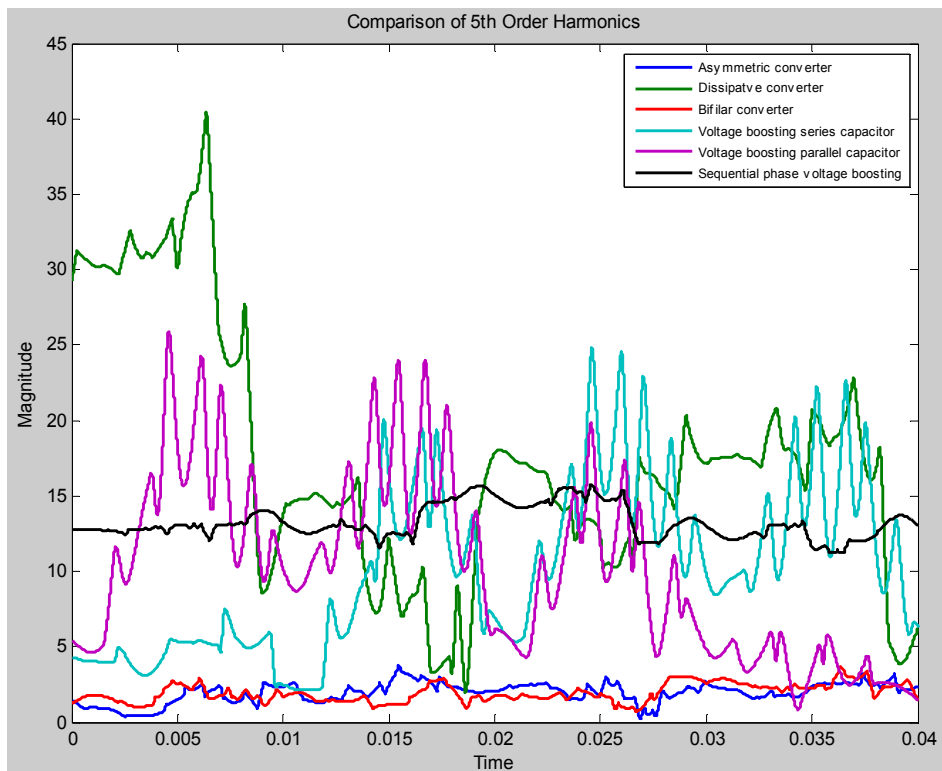

Fig. 14 5th Order Harmonics with Star Delta Transformer

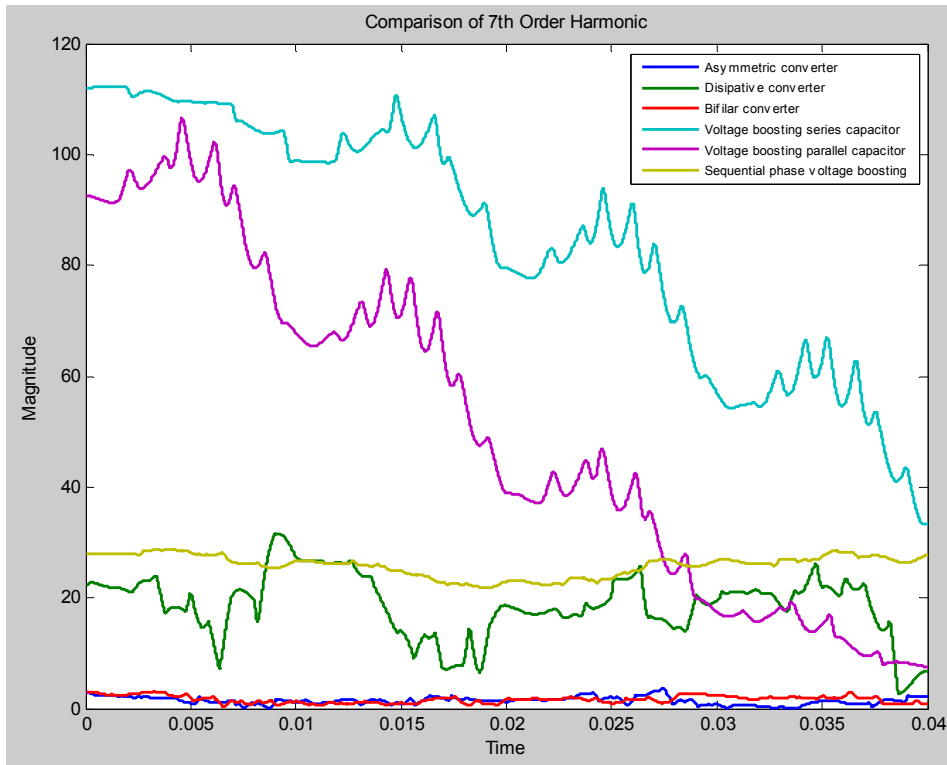

Fig. 15 7th Order Harmonics with Star Delta Transformer

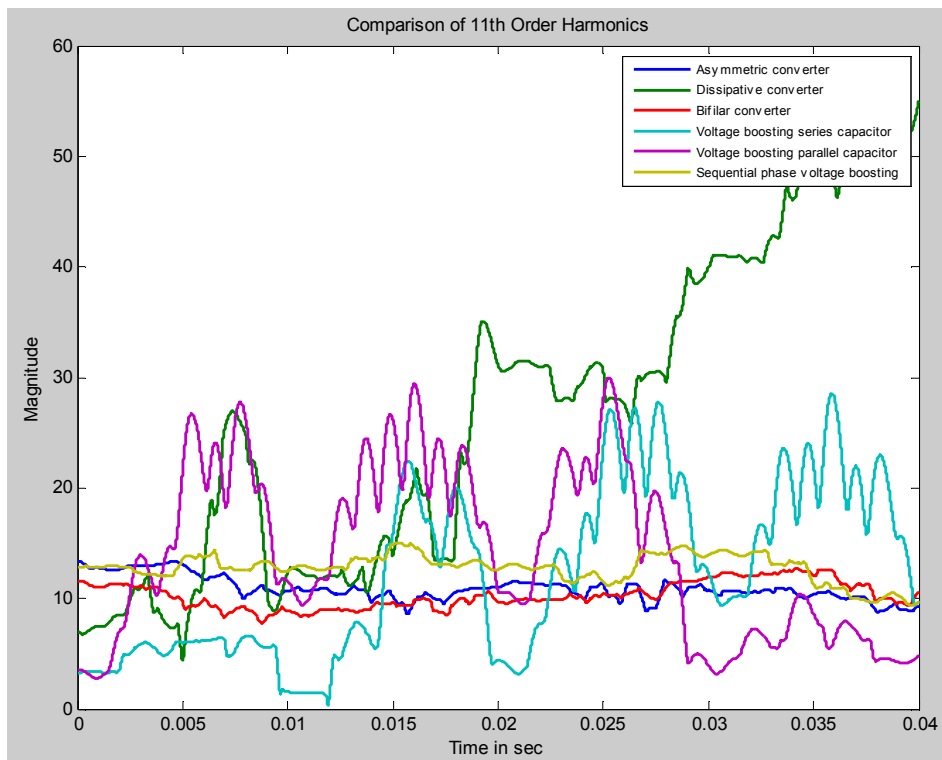

Fig. 16 11th Order Harmonics with Star Delta Transformer

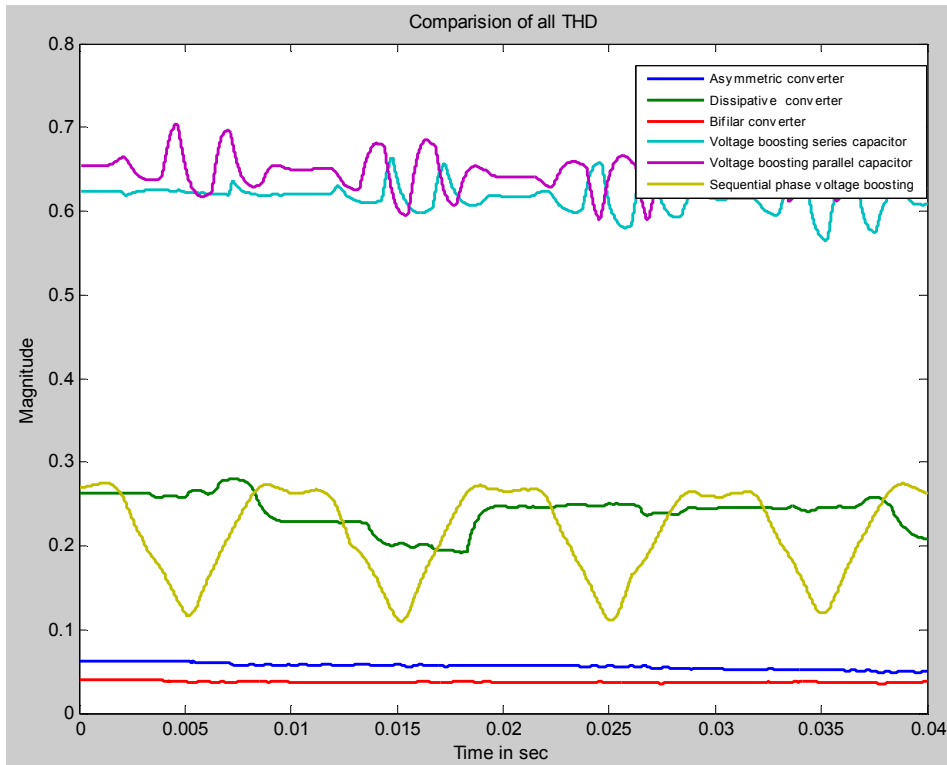

Fig. 17 Total Harmonic Distortion with Star Delta Transformer

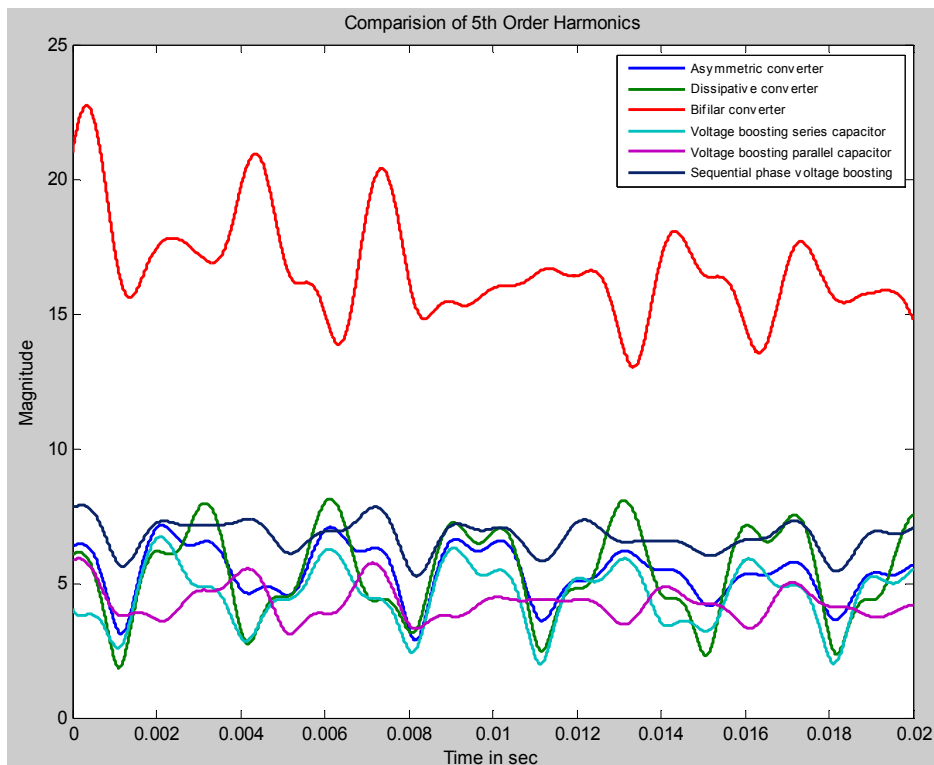

Fig. 18 5th Order Harmonics with Low Pass Filter

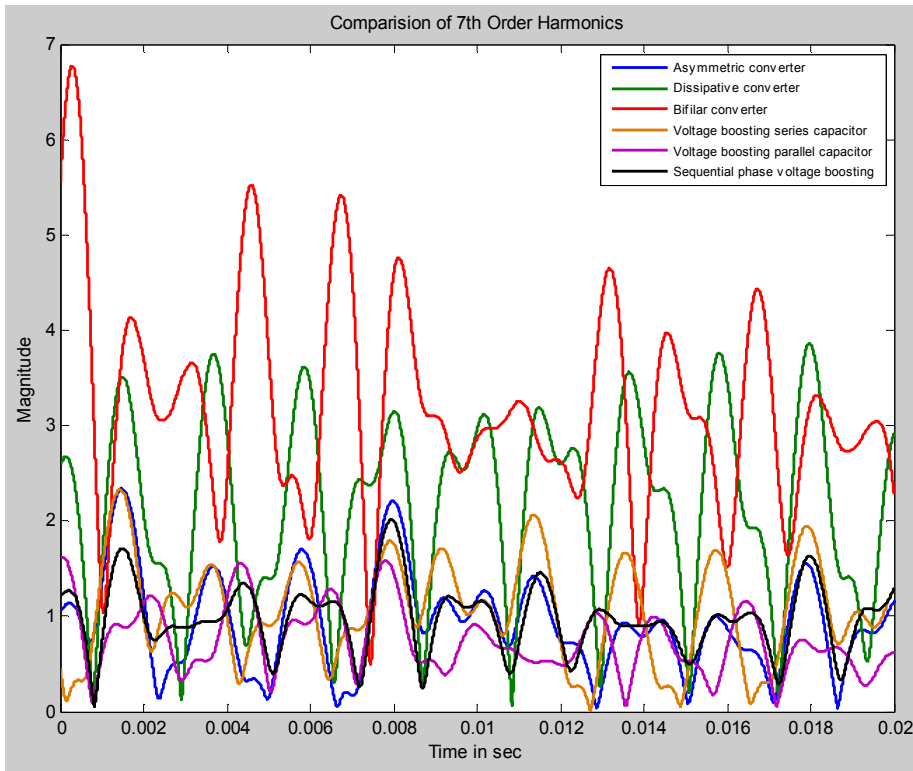

Fig. 19 7th Order Harmonics with Low Pass Filter

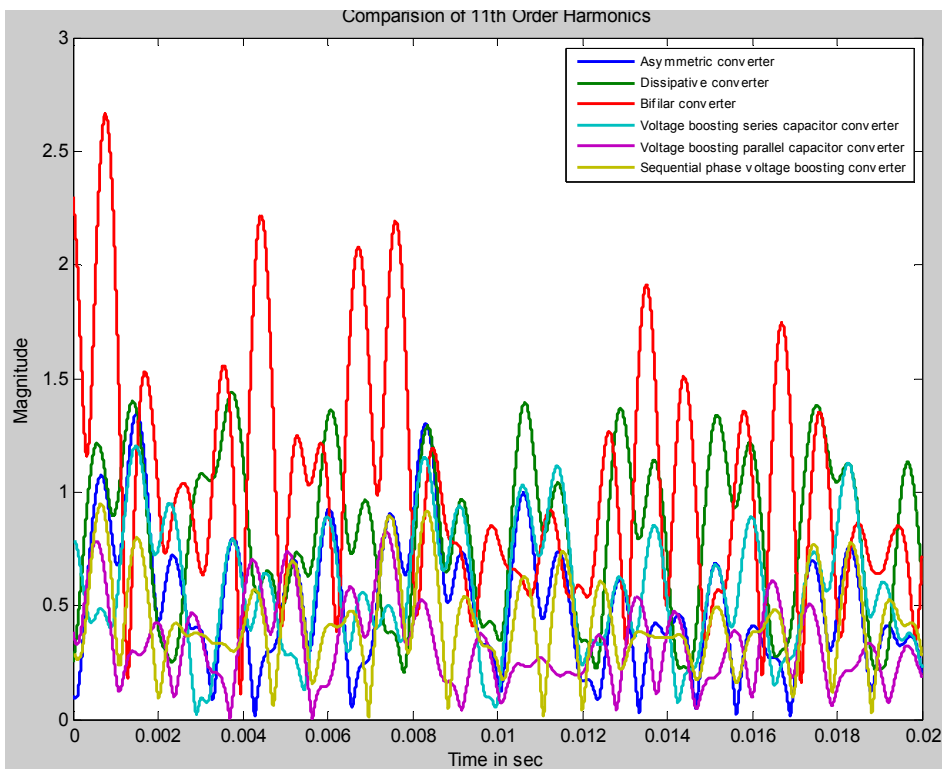

Fig. 20 11th Order Harmonics with Low Pass Filter

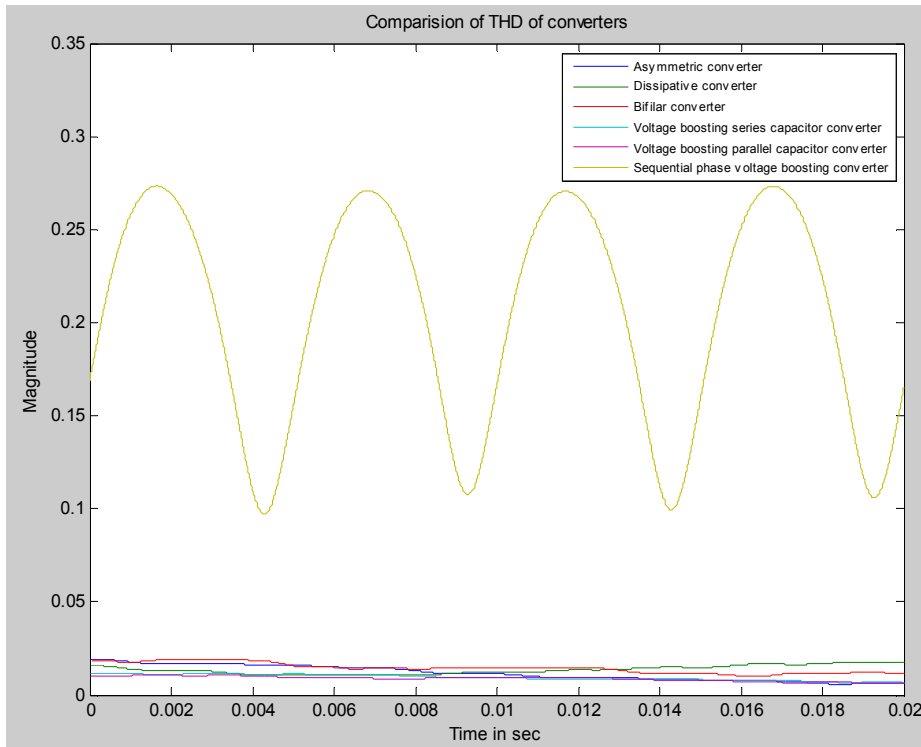

Fig. 21 Total Harmonic Distortion with Low Pass Filter

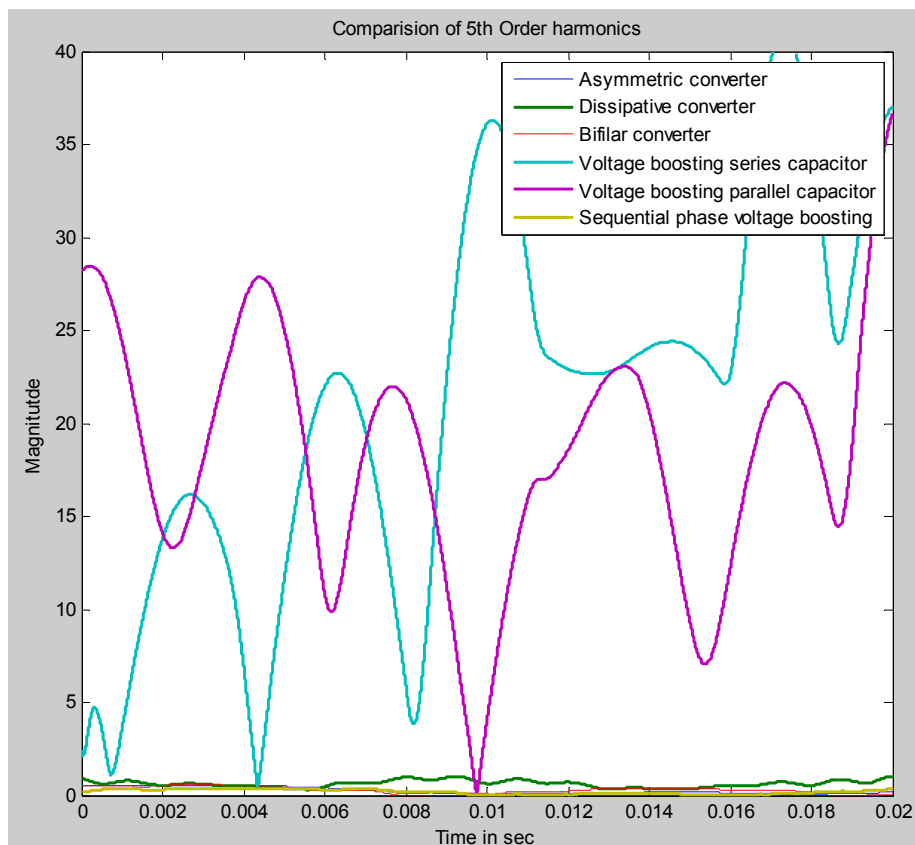

Fig. 22 5th Order Harmonics with Star Delta + Low Pass Filter

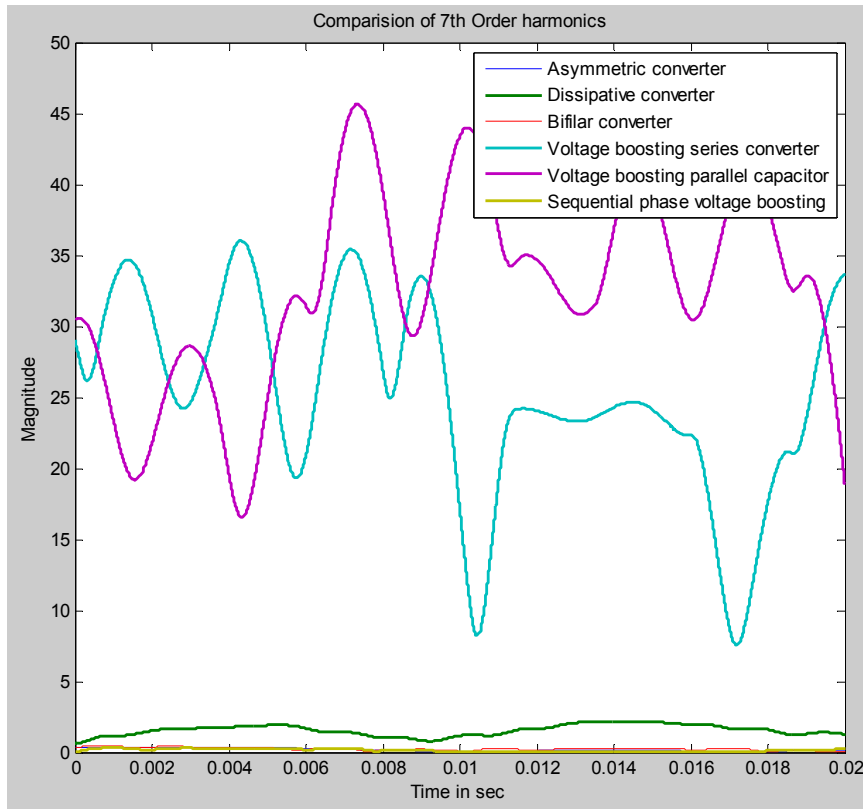

Fig. 23 7th Order Harmonics with Star Delta + Low Pass Filter

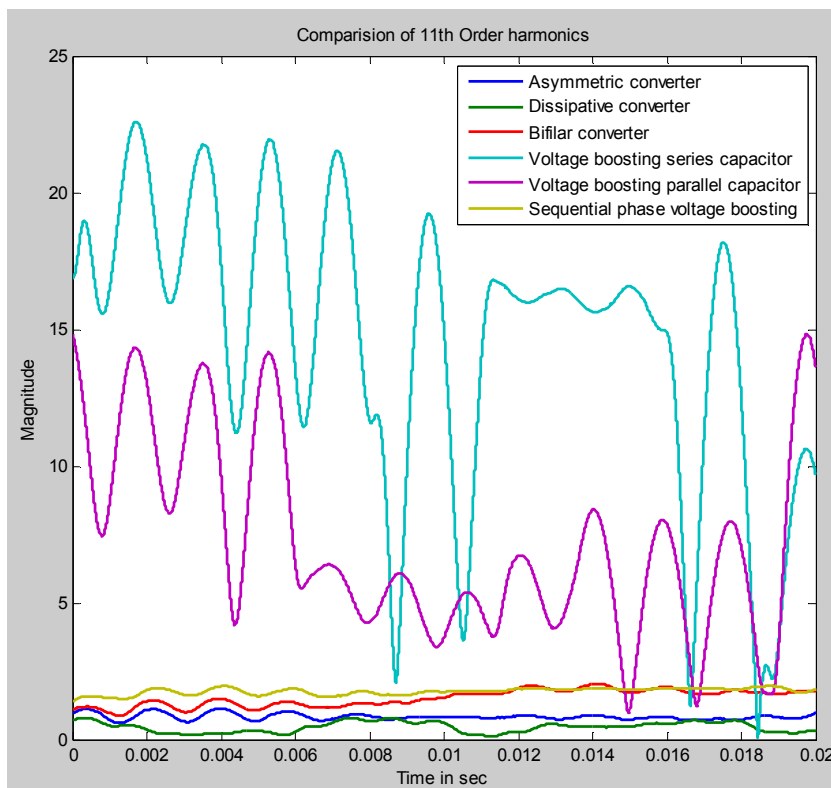

Fig. 24 11th Order Harmonics with Star Delta + Low Pass Filter

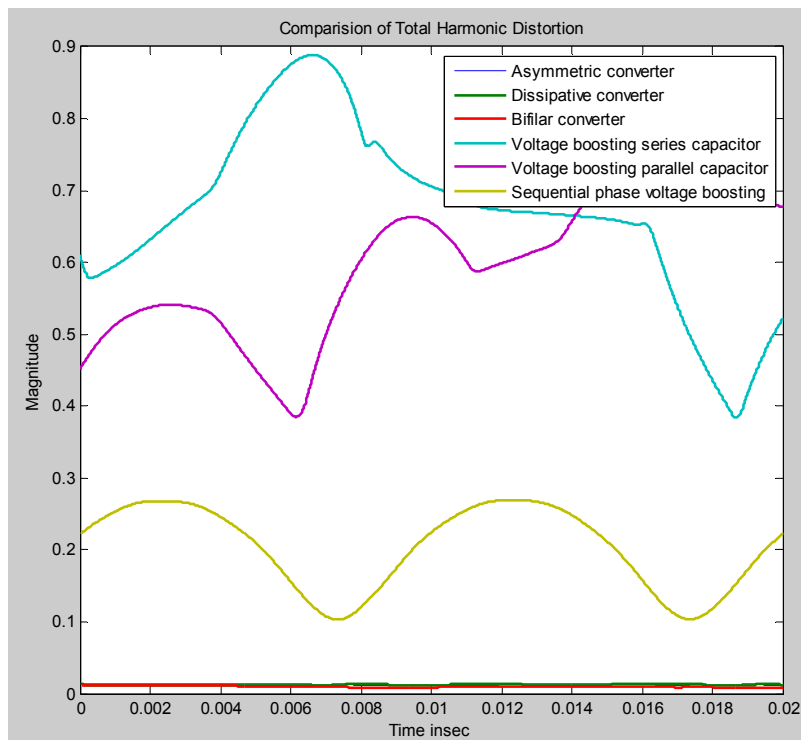

Fig. 25 Total Harmonic Distortion with Star Delta + Low Pass Filter

REFERENCES

- [1] G. Venkatesan, R. Arumugam, M. Vasudevan, S. Paramasivam and S. Vijayan, "Modeling and Simulation of a Novel Switched Reluctance Motor Drive System with Power Factor Improvement", *American Journal of Applied Sciences*, Vol. 3, No. 1, 1649-1654, 2006.
- [2] T. Anil Kumar, "Networks and Transmission Lines" First Indian print, pp 177-231, 2004.
- [3] John Stones and Alan Collinson "Introduction to Power Quality" *Power Engineering Journal*, pp 58 -64, 2001.
- [4] Slobodan Vukosavic And Victor R. Stefanovic, "SRM Inverter Topologies: A Comparative Evaluation" *IEEE Transactions On Industry Applications*, Nov/Dec. 1991, 27 (6), pp 946-958.
- [5] Vijay V. Deshpande and Jun Young Lim., "New Converter Configurations for Switched Reluctance Motors Wherein Some Windings Operate On Recovered Energy." *IEEE Transactions on Industry Applications*, Nov/Dec 2002, 38, (6), pp 1558-1565.
- [6] Krishnan, R.; Materu, P.N.; "Analysis and Design of a Low-Cost Converter for Switched Reluctance Motor Drives", *IEEE Transactions on Industry Applications*, March-April 1993, 29, (2), pp. 320-327.
- [7] Mike Barnes And Charles Pollock, " Power Electronic Converters For Switched Reluctance Drives.", *IEEE Transactions On Power Electronics*, November 1998, 13, (6), pp 1100 – 1111.
- [8] G. Venkatesan, R. Arumugam, S. Paramasivam, M. Vasudevan, and S. Vijayan, "Occurrence of Harmonics with Induction Machine and Switched Reluctance Machine: A Survey and Analysis" *Journal of Applied Sciences*, Vol. 6, No. 9, 2126 -2130, 2006.